

FAA-RD-81-111

**Project Report
ATC-112**

FAA Weather Surveillance Requirements in the Context on NEXRAD

**B. G. Laird
J. E. Evans**

19 November 1982

Lincoln Laboratory
MASSACHUSETTS INSTITUTE OF TECHNOLOGY
LEXINGTON, MASSACHUSETTS



Prepared for the Federal Aviation Administration,
Washington, D.C. 20591

This document is available to the public through
the National Technical Information Service,
Springfield, VA 22161

This document is disseminated under the sponsorship of the Department of Transportation in the interest of information exchange. The United States Government assumes no liability for its contents or use thereof.

1. Report No. FAA-RD-81-111		2. Government Accession No.		3. Recipient's Catalog No.	
4. Title and Subtitle FAA Weather Surveillance Requirements in the Context on NEXRAD				5. Report Date 19 November 1982	
				6. Performing Organization Code	
7. Author(s) Bruce G. Laird and James E. Evans				8. Performing Organization Report No. ATC-112	
9. Performing Organization Name and Address Massachusetts Institute of Technology Lincoln Laboratory P.O. Box 73 Lexington, MA 02173-0073				10. Work Unit No.	
				11. Contract or Grant No. DT-FA01-80-Y-10546 Task III	
12. Sponsoring Agency Name and Address Department of Transportation Federal Aviation Administration Systems Research and Development Service Washington, DC 20591				13. Type of Report and Period Covered Project Report	
				14. Sponsoring Agency Code	
15. Supplementary Notes The work reported in this document was performed at Lincoln Laboratory, a center for research operated by Massachusetts Institute of Technology, under Air Force Contract F19628-80-C-0002.					
16. Abstract The Federal Aviation Administration (FAA), National Weather Service and Air Force Weather Service are currently engaged in a program to develop a next generation of weather radars (NEXRAD) capable of satisfying (to the greatest extent possible) the common weather information needs of these agencies. This report identifies the unique FAA weather radar surveillance requirements and examines the technical issues that arise in attempting to meet these requirements with the NEXRAD strawman radar sensors and siting. Current air traffic control (ATC) weather data usage and statistics of aviation weather hazards and system efficiency are used to prioritize products needed for ATC. The strawman NEXRAD capability is then reviewed in the context of the identified weather products and factors such as: <ol style="list-style-type: none"> (1) effects of front end noise and weather return statistics (2) resolution and low altitude coverage constraints (3) the clutter environment associated with various siting options, and (4) data quality required for real time automated display of hazardous weather regions to ATC controllers <p>It is concluded that significant problems will arise in attempting to simultaneously provide terminal and en route weather surveillance by a single radar as envisioned in the NEXRAD strawman.</p> <p>An analytical/experimental research and development program is described to resolve the identified technical uncertainties in the NEXRAD strawman design for FAA applications. The suggested research and development program includes an operationally oriented interactive data gathering program to evaluate weather products at an ARTCC and TRACON using existing pencil beam S-band radars (e.g., similar to that at MIT) to be followed by similar evaluations in other key geographical areas (e.g., the southeast) using a transportable testbed. Both radar systems would incorporate special features to minimize the likelihood of false targets (e.g., due to obscuration and/or clutter) as well as automated display and short term prediction of hazardous weather regions for use by ATC controllers.</p>					
17. Key Words NEXRAD Doppler weather radar clutter			18. Distribution Statement Document is available to the public through the National Technical Information Service, Springfield, Virginia 22151		
19. Security Classif. (of this report) Unclassified		20. Security Classif. (of this page) Unclassified		21. No. of Pages 186	22. Price

ABSTRACT

The Federal Aviation Administration (FAA), National Weather Service and Air Force Weather Service are currently engaged in a program to develop a next generation of weather radars (NEXRAD) capable of satisfying (to the greatest extent possible) the common weather information needs of these agencies. This report identifies the unique FAA weather radar surveillance requirements and examines the technical issues that arise in attempting to meet these requirements with the NEXRAD strawman radar sensors and siting.

Current air traffic control (ATC) weather data usage and statistics of aviation weather hazards and system efficiency are used to prioritize products needed for ATC. The strawman NEXRAD capability is then reviewed in the context of the identified weather products and factors such as:

- (1) effects of front end noise and weather return statistics
- (2) resolution and low altitude coverage constraints
- (3) the clutter environment associated with various siting options, and
- (4) data quality required for real time automated display of hazardous weather regions to ATC controllers

It is concluded that significant problems will arise in attempting to simultaneously provide terminal and en route weather surveillance by a single radar as envisioned in the NEXRAD strawman.

An analytical/experimental research and development program is described to resolve the identified technical uncertainties in the NEXRAD strawman design for FAA applications. The suggested research and development program includes an operationally oriented interactive data gathering program to evaluate weather products at an ARTCC and TRACON using existing pencil beam S-band radars (e.g., similar to that at MIT) to be followed by similar evaluations in other key geographical areas (e.g., the southeast) using a transportable testbed. Both radar systems would incorporate special features to minimize the likelihood of false targets (e.g., due to obscuration and/or clutter) as well as automated display and short term prediction of hazardous weather regions for use by ATC controllers.

ACKNOWLEDGMENTS

The research for this paper has included extensive consultations with air traffic controllers, accident investigators at the National Transportation Safety Board, participants in the JDOP program, and members of the NEXRAD JSPO.

Visits have been made to the FAA Air Route Traffic Control Centers (ARTCC's) covering the Boston, NYC, and Atlanta regions. Discussions were held with NWS meteorologists stationed at the Center Weather Service Units at these en route facilities, as well as with ATC supervisors and individual sector controllers.

The FAA Terminal Radar Approach Control (TRACON) facilities at Boston (Logan International Airport) and Atlanta (Hartsfield International Airport) were also visited. The Operations Chiefs at both facilities provided a great deal of insight into the workings of the terminal approach control system with first-hand demonstrations. The cooperation and contributions of all of these people are gratefully acknowledged.

We have also benefited from discussions and suggestions from those associated with the Weather Radar Research Project at Lincoln Laboratory. Particular thanks are due M. Stone and D. Karp.

CONTENTS

ABSTRACT	iii
ACKNOWLEDGMENTS	v
LIST OF ILLUSTRATIONS	ix
LIST OF TABLES	xi
LIST OF ACRONYMS AND ABBREVIATIONS	xiii
INTRODUCTION AND EXECUTIVE SUMMARY	xv
I. ASSESSMENT OF WEATHER SERVICES REQUIRED FOR ATC	1
A. Observations on the Present ATC Environment	1
B. Statistics on Aviation Hazards and System Efficiency	11
C. Identification of Weather Surveillance Requirements and Products	18
D. Impact on Present ATC Operations	21
II. FAA WEATHER REQUIREMENTS AND RADAR METEOROLOGY	23
A. FAA Weather Requirements as Specified to NEXRAD JSPO	23
B. Comments on the State-of-the-Art in Radar Meteorology	29
1. Turbulence in Presence of Precipitation	29
2. Clear Air Turbulence and Wind Shear	34
3. Vertical Wind Fields	38
4. Hail	39
5. Low Level Wind Shear (LLWS) Detection	39
C. Assessment of JDOP NEXRAD Radar Design	41
1. Accuracy and Reliability of Measurements	41
2. Coverage and Resolution	51
3. Siting: Obstructions and Diffraction	55
4. Siting: Fixed and Moving Ground Clutter	61
5. Data Acquisition Strategy	64
6. Summary of Conflicts Between Terminal/Airport Surveillance and NEXRAD Network Usage	68

CONTENTS (Cont.)

III. SUGGESTIONS FOR FURTHER FAA INVESTIGATIONS	72
A. NEXRAD Basic Radar Design/Detection Issues	72
1. Obscuration Due to Range Aliasing	73
2. Clutter From Fixed Objects	87
3. Clutter Due to Moving Objects	95
4. Resolution at Long Range	98
5. Inadequate Update Rates	102
6. Performance Degradation Due to Diffraction	102
B. Terminal/Airport Radar Design/Detection Issues	102
1. Likelihood of Occurrence and Detectability of LLWS With Pulse Doppler Radar	103
2. Clutter Rejection Capability	106
3. Update Rates	107
4. Terminal Sensor Hardware	107
C. Feature Extraction, Tracking and Display Issues	108
1. False Alarm Reduction by Fixed and Moving Target Clutter Maps	110
2. False Alarm Reduction by Interscan Spatial Correlation	110
3. Scan to Scan Correlation, Contouring, Centroiding and Feature Tracking	110
4. Feasibility of Turbulence Detection and Tracking Using Spectral Width	111
D. Weather Radar Information System Architecture	112
E. Experimental Assessment of Key Issues	114
1. Existing Weather Radars	114
2. Transportable Testbed Facility	124
IV. CONCLUSIONS AND RECOMMENDATIONS	129
A. Essential/Achievable Capability with Joint-Use NEXRAD Network Alone	129
B. Essential/Achievable Capability with Joint-Use Networking Augmented by FAA Special Use Radars	130
C. Validation of NEXRAD Based Weather Surveillance System	133

CONTENTS (Cont.)

	<u>Page</u>
REFERENCES	135
APPENDIX A FAA-Designated Terminal Airports	A-1
APPENDIX B Proximity of Designated Terminal to Preliminary NEXRAD Locations	B-1
APPENDIX C Proximity of Designated Terminal to Revised NEXRAD Sites	C-1
APPENDIX D Description of Interim Testbed Using MIT Radar	D-1

ILLUSTRATIONS

Figure		Page
1.1	Existing Network of NWS Radars	2
1.2a	Stages in the Development of an Isolated Convective Cell	5
1.2b	Stages in the Development of an Isolated Convective Cell	6
1.2c	Stages in the Development of an Isolated Convective Cell	7
1.3	Squall Line Thunderstorm Outflow (schematic)	8
1.4	Illustration of Airborne Weather Radar Reflectivity Bias Due to Attenuation	10
2.1	Turbulence Intensity Scale Relative to Composite Aircraft Response	31
2.2	Reflectivity Map of 20 May, 1980 Thunderstorm Near Norman, Oklahoma	32
2.3	Spectrum Width Contour Map of 20 May 1980 Thunderstorm	33
2.4	Reflectivity Contours and Penetration 1 for 20 May 1980 Thunderstorm	35
2.5	Spectrum Width Contours and Penetration 1 for 20 May 1980 Thunderstorm	36
2.6	Enlargement of False Safe Region of Fig. 2.5	37
2.7a	Standard Deviation of Reflectivity Estimate vs Dwell Time	46
2.7b	Standard Deviation of Velocity Estimate vs Dwell Time	46
2.7c	Standard Deviation of Spectrum Width Estimate vs Dwell Time	46
2.8	SNR vs Range for Representative Precipitation Reflectivities	47
2.9	Clear Air Reflectivity SNR vs Range	48
2.10	Airport, Terminal, and En Route Coverage Requirements, Assuming a Single Sensor Sited at Airport	52
2.11	Coverage Statistics for Revised NEXRAD Siting	54
2.12	Horizon Angle from ECAC Model with Terrain Raised 50 Feet Compared to Optical Measurements	56
2.13	View to East from site About 1 nmi North of Salt Lake City Airport, Utah	57
2.14	Incidence of Monopulse Diffraction Errors at Logan Airport	58
2.15	Monopulse Azimuth Error Caused by Diffraction from Hanscom Smoke Stack with Aircraft at Boresight of DABSEF L-band Antenna	59
2.16	MLS C-band Elevation Errors due to Diffraction from Top of Hangar at J.F. Kennedy Airport	60
2.17	View Toward Philadelphia from Clementon DABS ASR-8 Site	62
2.18	Cell Suppression Map of Philadelphia Area as Seen by an ASR-8 at the Clementon, N.J. DABS Site	63
2.19	Ideal Behavior of C/N_0 and W_x/N_0 as Function of Range	65

ILLUSTRATIONS (Cont.)

3.1	Storm Geometry Which Leads to Obscuration Problems with Conventional Pulse Doppler Radar Systems	74
3.2	Dual Sampling Technique	76
3.3	Mean and Width Velocity Errors Due to Overlap of Weather Signals	77
3.4	Performance of Baseline System When Two Weather Signals Overlap	78
3.5	Dual Coherent Interval System	79
3.6	Example of Weather Obscuration Due to Range Aliasing	80
3.7	Effects of Decohered Second Trip Echo on First Trip Signal	81
3.8	Effects of Recoherence and Filtering on Overlapped First and Second Trip Signals	82
3.9	Comparison of System Performance in Obscuration	84
3.10	Orthogonal Signal Radar	85
3.11a	Comparison of NSSL and M.I.T. Clutter Levels	90
3.11b	Comparison of NSSL and M.I.T. Clutter Levels	91
3.11c	Comparison of NSSL and M.I.T. Clutter Data at 0.4° Elevation Angle	92
3.11d	Comparison of NSSL and M.I.T. Clutter Data at 0.4° Elevation Angle	93
3.12	MIT Site Clutter Above 30 dBz in the First and Second Trips	94
3.13	Example of Bird/Aircraft Cross-Section Distribution at Burlington, VT	96
3.14	Comparison of Weather Return SNR with Aircraft and Bird Returns	97
3.15	A) Single Doppler Horizontal Mesocyclone Signature of a Stationary Rankine Combined Radius B) Theoretical Mean Doppler Velocity Azimuthal Profiles Through a Rankine Combined Vortex	101
3.16	Frequency of Occurrence of Measured Mesocyclone Diameters	101
3.17	Transportable Testbed Block Diagram	127
D-1	Interim Testbed Radar at M.I.T.	D-2
D-2	Relation of Interim Testbed to Boston Area Features	D-3
D-3	View from Interim Testbed Toward Logan International Airport	D-4
D-4	View from Interim Testbed Toward L.G. Hanscom Airport	D-4
D-5	View from Interim Testbed Toward Needham, MA TV Towers	D-8
D-6	Suggested Configuration for Display of Weather Products at an ARTCC	D-8
D-7	Display Multiplexing of Targets and Weather Information at an ARTCC	D-9

TABLES

	<u>Page</u>
I.1 Essential/Achievable Weather Products Using NEXRAD Strawman Pulse Doppler Radars	xviii
1.1 General Aviation Accident Statistics, 1976-1978	12
1.2 Weather-Related General Aviation Accidents, 1976-1978	12
1.3 Summary of Commercial Carrier Accidents, 1976-1978	14
1.4 Partial List of CC Accidents Occurring From 1973-1980 Caused by Encounters with Either Low-Level Wind Shear or Cruise-Altitude Precipitation	22
1.5 Annual ATC Delay Statistics	16
1.6 Weather and Weather Avoidance in the En Route and Terminal/Airport Airspaces	17
2.1 FAA Requirements for Weather Radar Coverage, Resolution Accuracy and Update Rates	20
2.2 Summary of FAA Requirements for NEXRAD Products	24
2.3 Some Attributes of Meteorological Phenomena, With Definitions	25
2.4 Relation of Radar Observables to Principal Meteorological Phenomena	26
2.5 Characteristics of Low Level Wind-shear Disturbances Associated with Convective Storms	30
2.6 Illustrative Doppler Radar Characteristics	40
2.7 Illustrative System and Signal Processing Characteristics	42
2.8 Expressions for Variance of Estimates of I , v , σ_v	43
2.9 Integration Times and Rotation Rates for Doppler Measurements at Low SNR	45
2.10 Technological and Detection Issues that Distinguish En Route and Terminal Area Wx Surveillance Problems from Each Other	50
3.1 Distribution of MIT Clutter Mean Velocities at Close Range	66
3.2 Distribution of MIT Clutter Spectral Widths at Close Range	99
3.3 LLWS Detection Systems	100
3.4 Impact of Radar Sensor Parameters on Key Airport/Terminal Sensor Performance Factors	104
3.5 Desired Radar Characteristics for Near Term Studies	109
3.6 Tasks Associated with Experimental Assessment of NEXRAD Performance Using Existing S-Band Pencil Beam Radars	115
3.7 Near Term Color Display Usage at ARTCC CWSU	116
3.8 Initial PVD Display Usage at ARTCC	120
3.9 Transportable Testbed Equipment Features	122
4.1 Essential/Realistic Service From Joint-Use Networking of JDOP-Like NEXRAD Pulse Doppler Radars	128
	131

TABLES (Cont.)

C-1	NEXRAD Sites	C-2
C-2	High Priority Airports/Terminals	C-5
C-3	Low Priority Airports/Terminals	C-6
D-1	MIT Testbed Radar Characteristics	D-6

LIST OF ACRONYMS AND ABBREVIATIONS

AGL	Above Ground Level
ARTCC	Air Route Traffic Control Center
ASR	Airport Surveillance Radar
ATC	Air Traffic Control
AWDS	Automated Weather Distribution System
AWS	United States Air Force Air Weather Service
CAPPI	Constant Altitude Plan Position Indicator (Display)
CC	Commercial Carrier
CONUS	Continental United States
CWP	Center Weather Processor
CWSU	Center Weather Service Unit
DARC	Direct Access Radar Channel
dBz	Decibels Corrected for Range
DOD	Department of Defense
DOT	Department of Transportation
DVIP	Digital Video Integrator and Processor Format
EL	Elevation
FAA	Federal Aviation Administration
FAATC	FAA Technical Center
FSS	Flight Service Station
GA	General Aviation
GOES	Geostationary Operational Environment Satellite
I	Radar Reflectivity
ILS	Instrument Landing System
JAWS	Joint Airport Weather Studies (Project)
JDOP	Joint Doppler Operational Project
JOR	Joint Operational Requirements
JSPO	Joint System Program Office
KM	Kilometer
LLWS	Low Level Wind Shear
LLWSAS	Low level Wind Shear Alert System

LIST OF ACRONYMS AND ABBREVIATIONS (Cont.)

M/S	Meters Per Second
MSL	(Above) Mean Sea Level
NEXRAD	Next Generation Weather Radar
NOAA	National Oceanic and Atmospheric Administration
NTSB	National Transportation Safety Board
NSSL	National Severe Storms Laboratory
NTR	NEXRAD Technical Requirements
NUOC	NEXRAD User's Operations Concept
NWS	National Weather Service
P_d	Probability of Detection
P_{fa}	Probability of False Alarm
PIREP	Pilot Report
PPI	Plan Position Indicator (Display)
PRT	Pulse Repetition Time
RHI	Range/Height Indicator
SNR	Signal-to-Noise Ratio
SWAP	Severe Weather Avoidance Plan
TRACON	Terminal Radar Approach Control Facility
WFMU	Weather Formator and Multiplexor

INTRODUCTION AND EXECUTIVE SUMMARY

A. BACKGROUND

Weather radars are a primary source of weather information for real time Air Traffic Control (ATC) use by controllers, meteorologists and pilots. However, the existing weather radars have a number of deficiencies with respect to parameters measured, time availability, reliability and maintenance costs. In recognition of this, the Federal Aviation Administration (FAA), agreed to join the NWS, and United States Air Force Air Weather Service (AWS) in the establishment in August 1979, of the Joint System Program Office (JSPO) which will oversee procurement of a next generation of weather radars (NEXRAD) capable of satisfying to the greatest extent possible the weather surveillance needs of all three agencies.

In the interim, the FAA, NWS, and AWS are attempting to understand better their requirements for weather information and the practical limits that would be imposed in any operational system. An important requirement for the NEXRAD is to improve the detection of severe storms (especially, tornados). Research carried out at the National Severe Storms Laboratory (NSSL) and elsewhere have shown that velocity sensing by Doppler processing can significantly improve the detection of tornados. Also, velocity sensing has been shown to be potentially useful for detection of turbulence and/or low level wind shear. Consequently, the NEXRAD will be a Doppler weather radar.

The FAA weather radar needs differ from those of the NWS/AWS meteorological community in that the weather radar products are observed continuously and utilized by nonmeteorologists (in particular, by air traffic controllers). This real time usage by nonmeteorologists places unusual demands on the NEXRAD data timeliness and data quality.

The objective of the work reported here is to identify the unique FAA weather radar surveillance requirements and examine the likelihood of meeting them with a strawman NEXRAD system. Particular emphasis is placed on the terminal/airport regions since these have been associated with the majority of weather related fatal accidents, and involve factors which have not received adequate attention from the NWS/AWS radar meteorological community.

B. REPORT ORGANIZATION

Chapter I considers the weather services which are required for ATC. First, the weather services presently available in the ATC environment are examined. It is shown that the present data on the location of storms and the observed features (i.e., reflectivity only) are insufficient to identify principal hazards in the terminal/airport regions as well as having some deficiencies in the en route region.

Statistics on aviation hazards and system efficiency are reviewed in Section B to determine which weather features are of greatest concern for improved safety and reduction of weather delays. It is found that unusually heavy precipitation (at any altitude) and low level wind shears encountered on landing or takeoff are of greatest concern for safety. En route turbulence is mainly an unpleasant nuisance to commercial carrier aircraft; turbulence associated with thunderstorm/clouds has been identified as a significant cause of fatal general aviation aircraft accidents. Better real-time reporting of turbulent regions can lead to increased comfort and safety. Accurate short term forecasts of precipitation and wind shears in the terminal area could provide substantial reduction in airborne weather delays.

The statistical analyses and operational procedures review are then used to identify weather surveillance requirements and products for the en route and terminal areas in section C. The impact of the proposed real time weather information system on other ATC operations is considered in section D.

Chapter II considers the FAA weather requirements in relation to:

- 1) the current radar meteorological state of art and,
- 2) the capabilities of the strawman NEXRAD system based on the Joint Doppler Operational Project (JDOP) suggested radar [23]

Section A reviews the FAA requirements as specified to the NEXRAD JSPO in 1979 [24]. Next, the radar meteorological capabilities are considered, placing particular emphasis on those items which stress the current state of art. These principal challenges include:

- (a) identification of turbulence in the presence of precipitation
- (b) detection of clear air turbulence and wind shear at low altitudes
- (c) estimation of low altitude vertical wind fields, and
- (d) hail detection

Section C assesses the capability of the strawman NEXRAD system (i.e., JDOP strawman radar and proposed NEXRAD siting [64]) to accomplish the desired objectives. This capability assessment includes:

- (1) the effects of front end noise and weather return statistics on the measurement times required to meet the accuracy goals
- (2) coverage and resolution constraints, and
- (3) the impact of the ground clutter environment on siting

Significant problems are shown to arise in developing a radar design/siting plan which can meet the needs imposed by (1)-(3) for both terminal/airport and en route service.

C. PRINCIPAL CONCLUSIONS

1. Essential/Achievable NEXRAD Capability

The FAA requirements for NEXRAD products do not make any distinction between those products to be used in the en route region as opposed to the terminal/airport regions. Based on the statistics of weather related accidents and the radar meteorological capabilities of the pulse Doppler radars, we have concluded that there are significant differences in the essential, achievable automated capability to be provided in these different regions. Table I.1 summarizes the weather products which represent realistic goals at this time for the FAA provided that NWS/AWS would agree to some relatively minor changes in NEXRAD requirements.

EN ROUTE REGION

For the enroute airspace, NEXRAD can perform reliable surveillance using radar reflectivity as the principal weather characteristic. The system must be capable of automatic tracking of reflectivity cells. Doppler features will also be measured, but often with large estimate variance and/or bias errors due to inadequate resolution. To the extent that it proves feasible to do so, the system should also track strong coherent Doppler features embedded in precipitation. Examples of this would be mesocyclones, tornados, and possible turbulence cells and shear fronts. Coverage of high altitude portions of nearby terminal and airport airspaces will be automatic. Reliable radar detection of clear air turbulence and wind shear in the identified en route region (e.g., above 6 kft altitude) is viewed as unrealistic due to the extremely low signal to noise ratios which will occur.

TERMINAL/AIRPORT REGIONS

In the terminal/airport regions, high quality information on low level wind shear and turbulence features is also required due to high likelihood of encountering such hazards without precipitation in the same spatial volume. Another distinguishing characteristic of the airport/terminal environment is the need for faster update rates due to the pattern of operational use of approach/departure corridors as well as the time scale of evolution for the weather hazards of concern (especially, shear).

The likelihood of meeting the FAA terminal/airport weather surveillance requirement with a network NEXRAD radar while simultaneously meeting the requirements of NWS/AWS appears to be very low. The principal difficulties include siting, clutter suppression, and data rate/scan pattern. Consequently, we have concluded that the weather surveillance needs in the airport/terminal airspace are best met by an airport-based radar optimized for high update rate surveillance and clear air wind shear detection. The full volume coverage, including the airspace above the airport, would be provided by adjacent NEXRAD sensors and/or the ASR-9 with a weather channel.

TABLE I-1
ESSENTIAL/ACHIEVABLE WEATHER PRODUCTS USING
NEXRAD STRAWMAN PULSE DOPPLER RADARS

REALISTIC EN ROUTE SERVICE

FULL VOLUME SCAN EVERY 5 MINUTES DOWN TO RADAR HORIZON
DETECTION, CONTOURING AND TRACKING OF INTENSITY FEATURES
DETECTION AND TRACKING OF SEVERE TORNADIC FEATURES USING
DOPPLER CAPABILITY
POSSIBILITY FOR DETECTION OF TURBULENCE OR SHEAR FEATURES
IN PRECIPITATION
DETECTION AND TRACKING OF HAIL AND FREEZING/MELTING LEVEL
(PERHAPS NOT TO MAXIMUM RANGE)

REALISTIC TERMINAL/AIRPORT SERVICE

FULL VOLUME SCAN EVERY 5 MINUTES
COVERAGE OF CONE OF SILENCE WITH ADJACENT NEXRAD COVERAGE
AND/OR ASR-9
FEATURE TRACKING WITH 30 SECOND UPDATE RATE
- PRECIPITATION FEATURES - USING INTENSITY
- SHEAR AND TURBULENCE FEATURES - USING MEAN VELOCITY
AND SPECTRUM WIDTH
REDUCED SCAN RATE AT BOTTOM ELEVATION ANGLE FOR CLUTTER
REJECTION AND LLWS DETECTION

The degree to which the NEXRAD basic radar could (with appropriate changes in measurement strategy and software) serve as the airport/terminal sensor depends critically on the clutter environment and clear air reflectivity levels. An analytical/experimental program to resolve the technical uncertainties in these areas is outlined in Chapter III.

WEATHER INFORMATION SYSTEM CONCEPT VALIDATION

The NEXRAD is one element of the FAA improved weather information system. Another key element of this system is The Center Weather Processor (CWP), which will provide the integration and dissemination of weather data from a variety of sensors to principal FAA users. There is a pressing need for the validation of the entire NEXRAD/ASR-9/CWP concept by operational user assessment of the recently developed (and still evolving) NEXRAD based hazardous weather detection techniques in representative air traffic control applications. Examples of the problems include:

- (a) lack of experience in using the NEXRAD products for real time ATC,
- (b) a paucity of relevant Doppler weather data from key areas of significant hazardous aviation weather activity (especially, the southeast US) and representative sites,
- (c) minimal attention to the terminal/airport region problem in both the NEXRAD and the CWP programs, and
- (d) minimal attention to the NEXRAD/CWP interface to determine how the CWP processing will impact on the FAA NEXRAD requirements.

It is recommended that the problems described be resolved by a two phase program. The first phase would be an interactive, data gathering program to obtain feedback from operational ATC personnel on the utility of the various weather products. This would be accomplished by using representative radars, signal processors and weather product generators with weather products being furnished in real time to one (or more) ATC facilities*. Concurrent with this operationally oriented data gathering activity, smaller scale research oriented programs (e.g., JAWS project data reduction) should be carried out to develop additional weather detection capabilities.

A significant amount of the phase one data gathering activity could be carried out by adding signal processing and display capability to existing FAA experimental sites*. However, the site/region dependency studies will require movement of a radar and signal processing system to appropriate locations. It is unlikely that existing mobile weather radars could be made available for

*Real time data should be provided to ATC facilities to permit the comparison of the weather radar with other available real time data (e.g., CWSU meteorological data and (solicited) pilot reports) as well as simplifying the logistics of obtaining knowledgeable operational users.

sufficiently long periods to accomplish the FAA program. Thus, it will probably be necessary to assemble a movable radar using existing FAA equipment to accomplish the required studies at a low cost and on a time schedule consistent with impacting the NEXRAD and CWP programs.

In the second phase, candidate NEXRAD radars would be interfaced to a prototype CWP processor to furnish weather products for operational evaluation by meteorologists and controllers. This work will need to be accomplished as early as possible since many difficult issues regarding controller procedures will need to be resolved. Also, operational procedure experiments may reveal additional requirements for the NEXRAD sensor.

I. ASSESSMENT OF WEATHER SERVICES REQUIRED FOR ATC

A. Observations on the Present ATC Environment

The weather services available to the civil aviation community are provided jointly by the NWS, the FAA, and to some extent by the AWS. A detailed description of many of these services can be found in Reference 12. In this section, some of the features of the present system are discussed in order to provide a context for possible improvements to be developed in the sequel.

The NWS obtains weather observations from three principal sources:

1. A network of ground observing stations, each of which generates an hourly sequence report on local weather conditions.
2. A continental network of 59 weather surveillance radars, most of them WSR-57's which provide reflectivity information on storms within 250 km (see Fig. 1.1). The AWS has augmented this network with 22 FPS-77's, located primarily in the western states.
3. Two geostationary operational environment satellites (GOES), which provide twice hourly cloud coverage photographs of the eastern and western halves of the U.S.

This information is used to produce hourly forecasts which are available to the FAA along with the local weather observations.

The FAA facilities which make use of this (and other) information include Air Route Traffic Control Centers (ARTCC's), Terminal Radar Approach Control Centers (TRACON's), and Flight Service Stations (FSS's). There is also an ATC Systems Command Center/Central Flow Facility which receives information from the 20 ARTCC's and 18 of the major TRACON's. This information is used to coordinate the ATC network response to any special emergencies, including weather delays.

Different facilities in this network have evolved tailored regional solutions to their more pressing weather problems. In each case, the methods employed take into account the regional weather patterns, the existing equipment, the level of training of personnel, and the load factors of the facility. With few exceptions, the ARTCC's are significantly better off than the TRACON's in terms of access to timely, accurate weather data. Seven of the 20 ARTCC's have a Center Weather Service Unit (CWSU) staffed by trained NWS meteorologists. The CWSU meteorologist has at his disposal a variety of sources of weather information, among them:

1. Local en route radar broad-band reflectivity, or WFMU processed data.

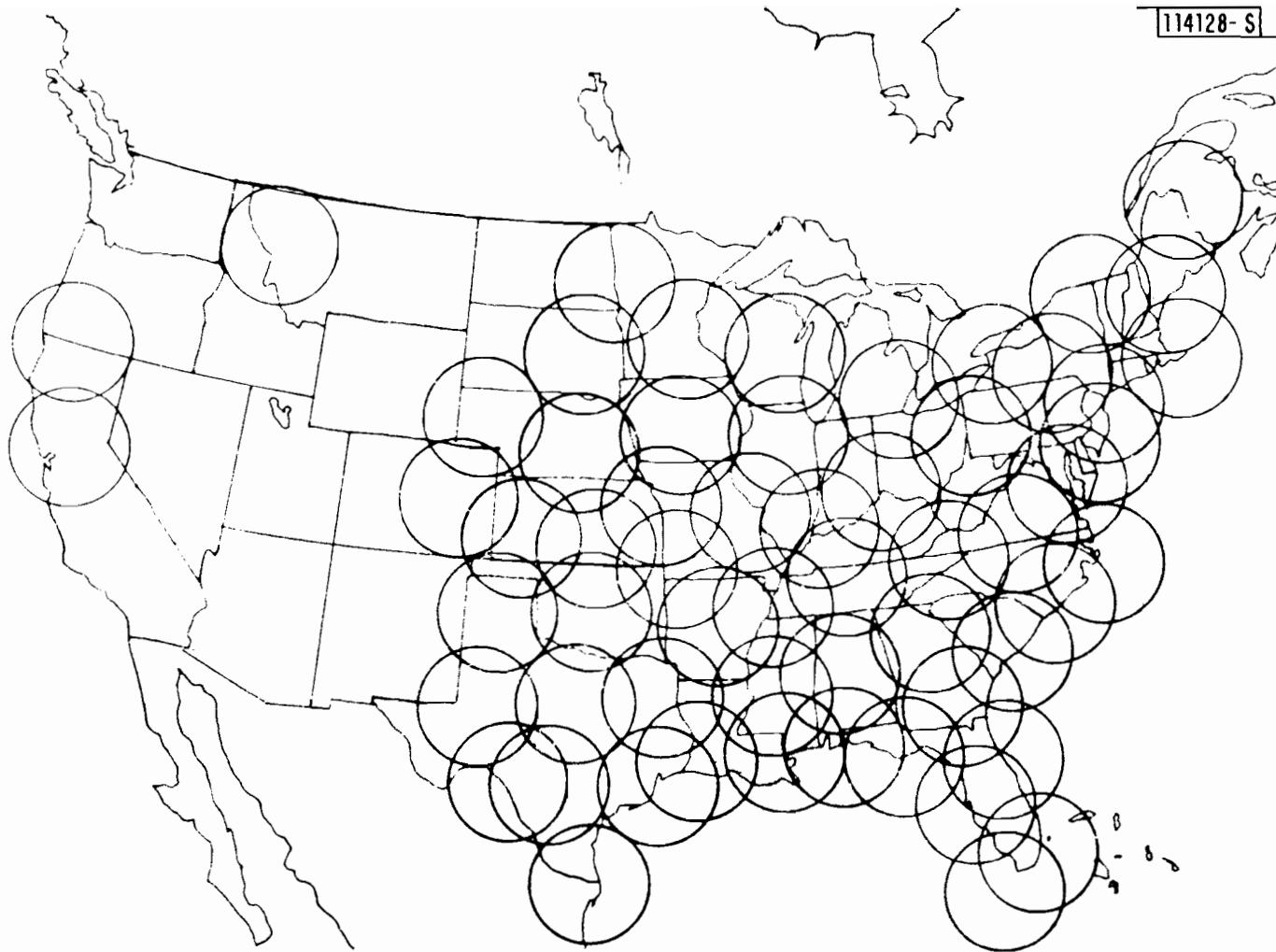

Fig. 1.1. Existing Network of NWS radars.

2. GOES Satellite photos transmitted via fax every 30 minutes, arriving with approximately 15 minutes delay.
3. DVIP format reflectivity information from one or more regional NWS radars.
4. Teletype service A: hourly sequence reports.
5. Pilot reports relayed through sector controllers.

From these sources, the meteorologist assembles and constantly updates a broad picture of the regional weather hazards. The information is shared periodically with the ARTCC Flow Controller, and it is used to make strategic (tens of minutes to hours in advance) decisions about changes in the traffic flow pattern through the ARTCC's airspace.

Summary information is sent via teletype service B to TRACON, Terminal Cab, and FSS facilities* within the ARTCC region. In addition, the CWSU meteorologist prepares a formal briefing on the weather forecast for the next 8 hours, which is given to all sector controllers before coming on duty. He is also available for consultation with individual controllers at any time.

TRACON controllers have four principal sources of information on a severe weather hazard as it moves into the terminal area:

1. Broadband reflectivity information from a local terminal radar (ASR) which they can view on their displays.
2. Storm advisories issued by the CWSU in the regional ARTCC via service B teletype.
3. Visual observations made by pilots and the Tower Cab controllers, which are passed along as part of the dialogue between ATC's and pilots.
4. Warnings received in the Tower Cab from a low level wind shear alert system (LLWSAS).

At the present time, controllers rely most heavily on the visual observations and on their own broadband radar information. The broadband radar reflectivity information is often of limited utility as a direct indicator of turbulence because the updrafts/downdrafts can spread out near the ground such that regions of significant turbulence and wind shear can be found at

*We have not considered the use of real time weather radar data by FSS personnel who give briefing to general aviation and business pilots on the grounds that the FSS facilities will probably use the CWSU MX predictions rather than directly accessing weather radar data.

considerable distance from the region with rain drops. Figures 1.2 and 1.3 illustrate this phenomena in the context of single isolated convective cells and when multiple cells are present.

The practice that is followed with regard to airport closure during passage of severe thunderstorm features varies considerably from airport to airport. However it is typically the case that airports stay open as long as possible, only closing for a few minutes while the worst of the storm moves through. Operations statistics taken at LaGuardia Airport^[38] confirm the fact that in the terminal airspace, it is not uncommon for pilots and controllers to operate tactically to avoid hazardous storm features. They do this at present on the basis of relatively poor quality information* about hazardous storm cells in the area, and tragic results have occurred. The Eastern 66 crash at JFK, and the Continental crash at Denver^[29,28] are two examples.

In the en route airspace it is often the case that the pilot has better short-term weather information than the sector controller. This is particularly true of commercial carriers (CC) who are required by law to be equipped with weather radar. When cruising at altitude in the en route airspace, the weather radar equipped (e.g., CC and, many business aircraft) pilot can detect hazardous storm features 50 to 100 miles ahead. Frequently these features are not detected and displayed by the WFMU processing of the ground-based en route radar system. When the sector controller is alerted to their presence by the pilot, he may switch to his broadband display, which shows the reconstituted raw PPI intensity information from one of the en route radars used by the center. Unfortunately, this presentation does not show any aircraft beacon data, and it is not displayed on the same scale as the standard Plan View Display (PVD) which shows the air traffic information.

Sometimes the controller can identify a region of high reflectivity on the broadband or WFMU displays which seems to coincide with the cell depicted by the pilot's radar, but this is not always so. This creates a situation in which the pilot requests a vector or an altitude change to avoid a potentially hazardous weather feature that is invisible to the controller. Of course, the same situation arises when an aircraft encounters clear air turbulence, which is invisible to both.

Depending on the visibility conditions, apparent storm top height, severity, etc., the weather radar equipped CC pilot will request permission to deviate either around or over a potentially hazardous storm cell. One or two thousand foot changes in altitude are commonly requested to drop below or rise above discomforting pockets of turbulence, frequently encountered in clear air.

*In particular, it follows from Figures 1.2 and 1.3 that the airborne weather radar regions of high reflectivity will be a poor indication of low altitude turbulent/high wind shear regions.

SINGLE CELL — INITIAL STAGE

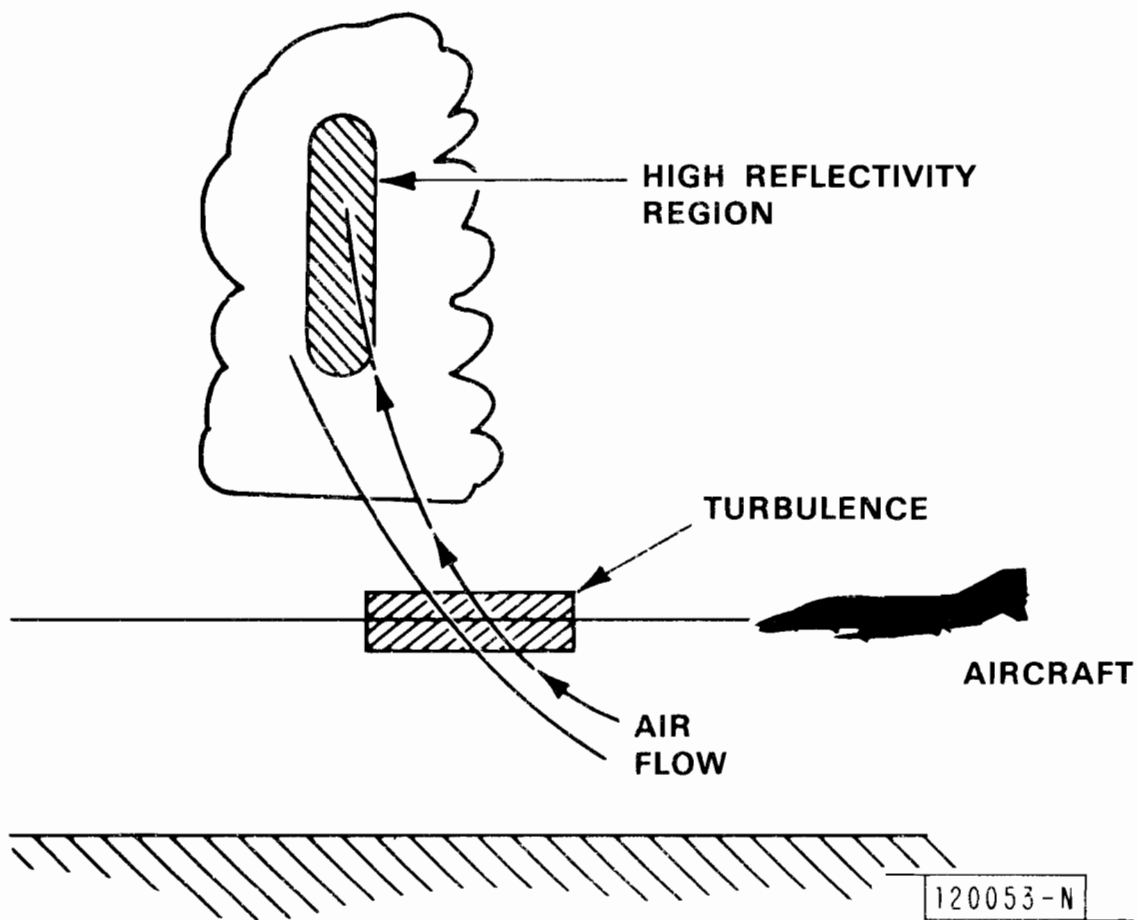

Fig. 1.2a. Stages in the development of an isolated convective cell.

SINGLE CELL — SECOND STAGE

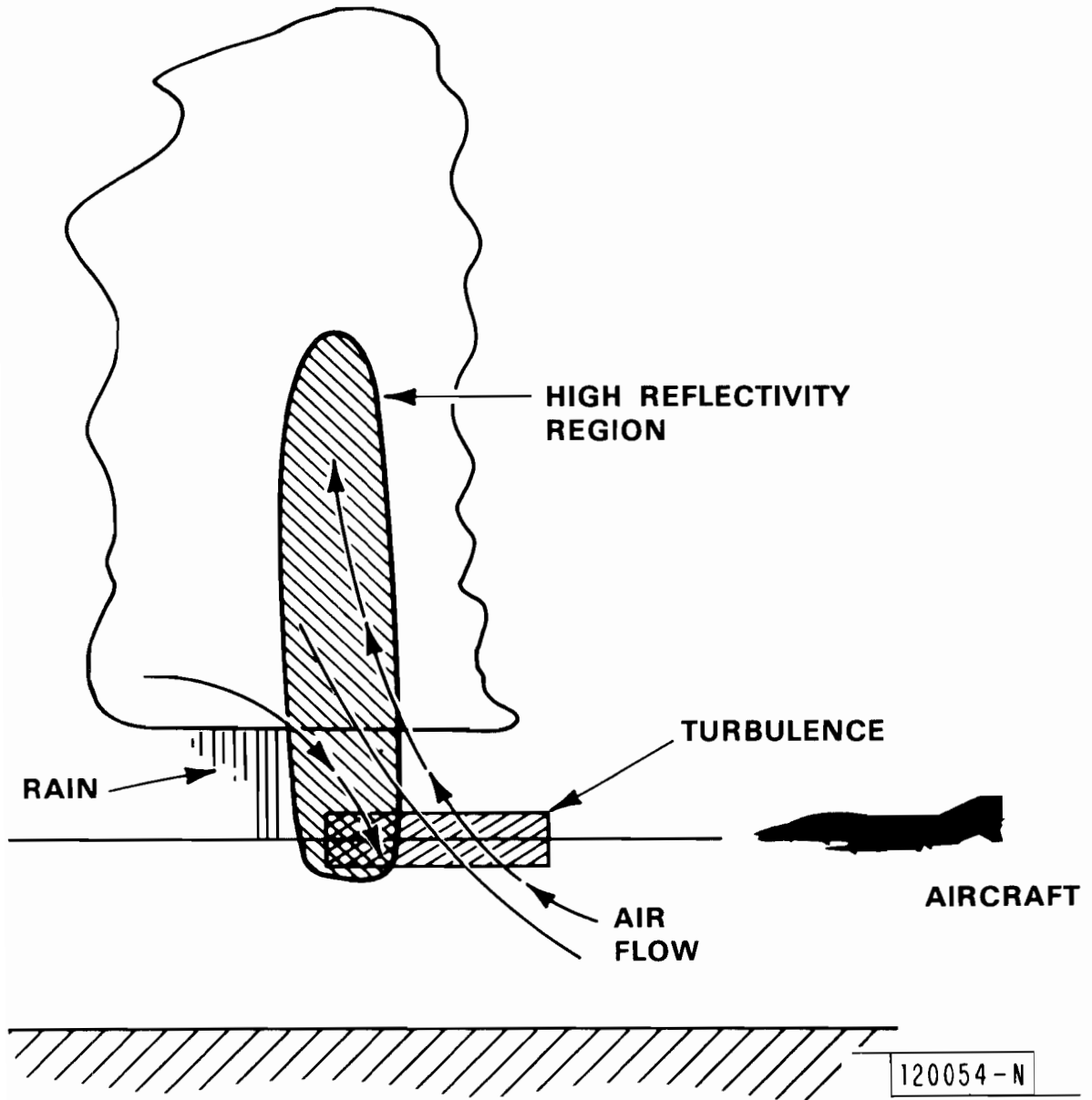

Fig. 1.2b. Stages in the development of an isolated convective cell.

SINGLE CELL — RAIN ON GROUND

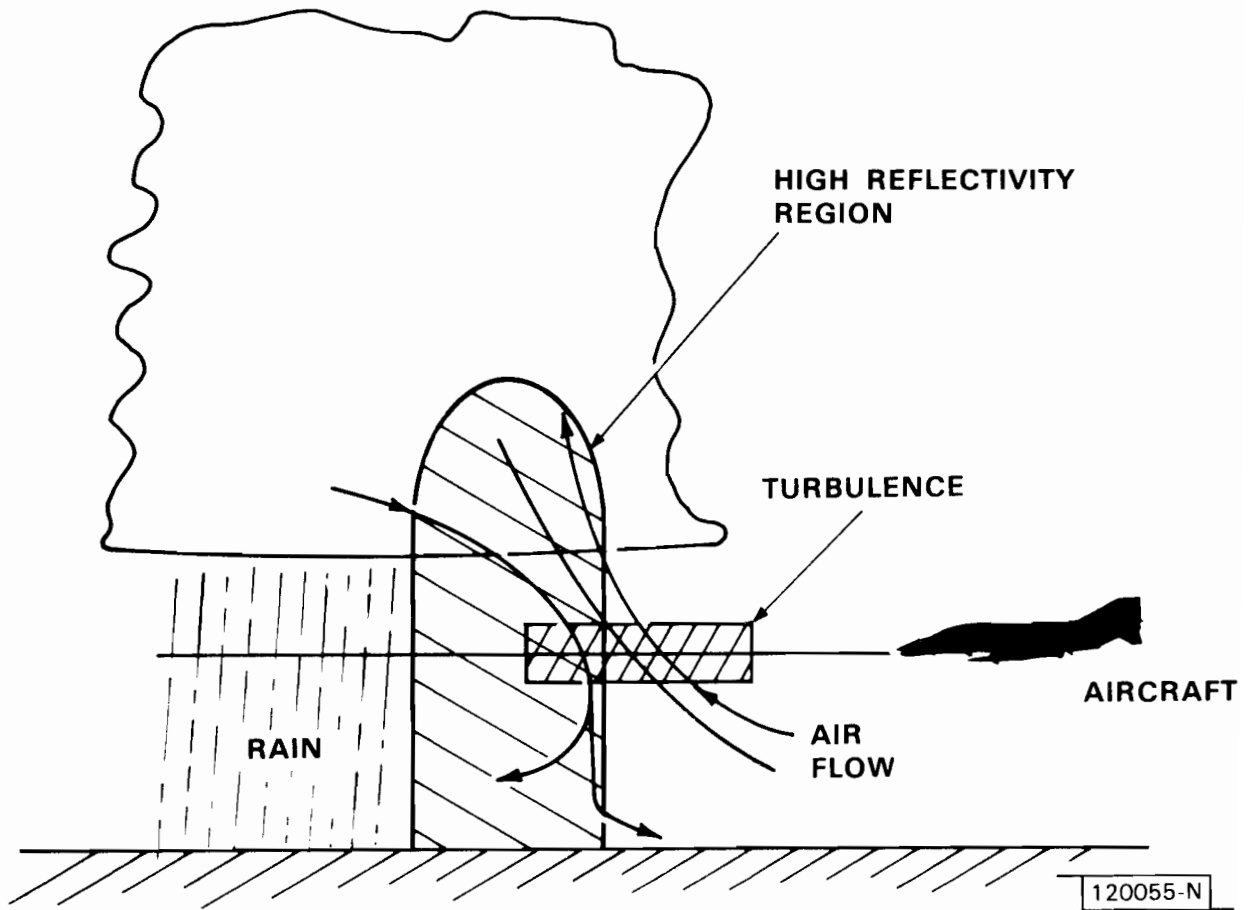

Fig. 1.2c. Stages in the development of an isolated convective cell.

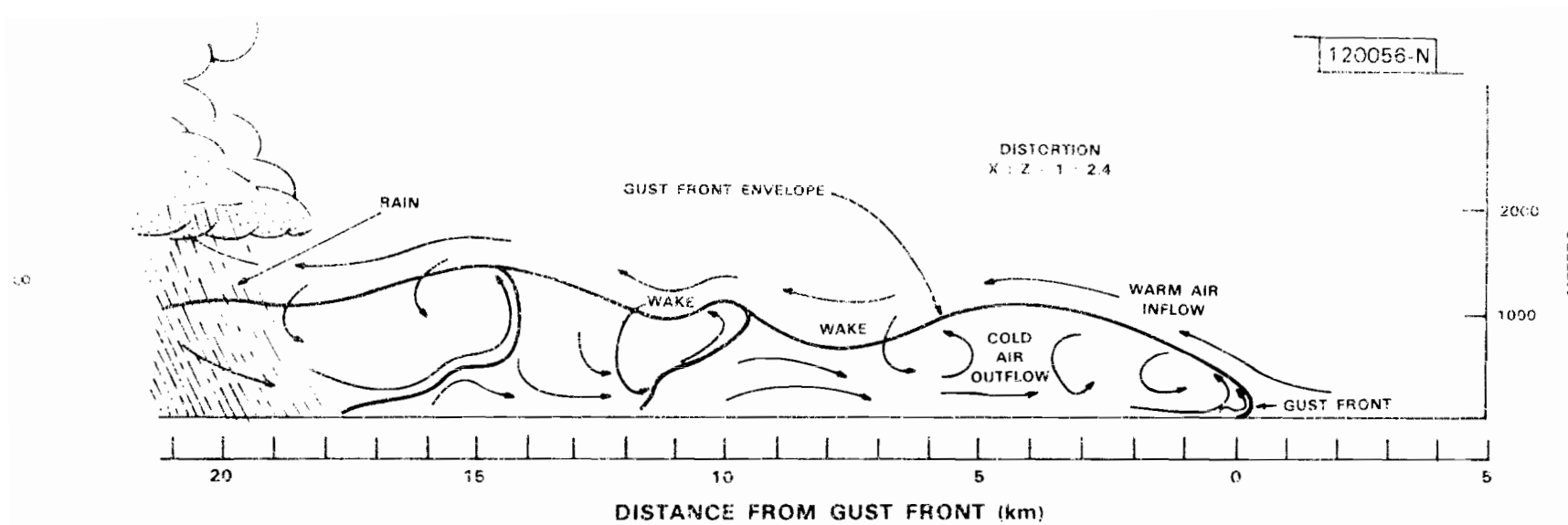

Fig. 1.3 Squall line thunderstorm outflow (schematic).

The enroute controller normally accommodates these requests, and in fact, builds up a mental picture of the hazardous conditions in his sector of the airspace, by means of pilot reports (PIREPS) from flights that are traversing it. Controllers will often brief this information to pilots entering their sectors, and it is certainly more accurate than the pre-flight weather briefings given by company dispatchers and Flight Service Stations, which are using information that may be 1-2 hours old.

Although the weather radar equipped pilot generally has a better short term assessment of hazardous regions from his display than is available to the enroute controller, this may not be the case in particularly severe (e.g., hazardous) conditions due to rain attenuation. In particular, it has been shown that the severe attenuation of airborne weather radar signals by heavy precipitation can present a misleading view of the actual storm structure to the pilot. Figure 1.4 illustrates these differences which are believed to have occurred with the Southern Airways crash near Rome, Georgia in 1978 [27, 46], in which the pilot attempted to fly through a narrow sector of the storm front.

Sector controllers state that they could handle traffic much more efficiently if they had a more complete picture of even the reflectivity features of storms. To this end, the Air Traffic Service of the FAA has placed auxiliary weather displays in both ARTCC's and TRACON's on a trial basis. The data for these displays comes from local WSR-57 weather radar sites operated by NWS. These sites provide as a public service a real-time output of reflectivity (quantized using the standard NWS 6-level code) in Digital Video Integrator and Processor (DVIP) format. This format is designed to support transmission over a voice grade phone line on a dial-up basis. When appropriately processed, the data are used to drive a reconstituted PPI display on a color monitor, with each of the six reflectivity levels displayed as a different color.

The DVIP output is continuously available as long as the NWS meteorologists are operating the radar in a 360° azimuth scan pattern (typically 1° elevation, 3 rpm). Occasionally they stop the antenna and do one or more Range-Height Indicator (RHI) scans (vertical cuts) through a storm of interest. During this time there is no transmission of reflectivity data, and unless special equipment is provided at the receiving sites to preserve the most current information, the video picture is lost until the antenna resumes an azimuth scan pattern. An additional limitation of this system is that the CWSU meteorologist has no way of knowing the elevation angle being used, and so can only outline the horizontal dimensions of potentially hazardous storm areas.

The availability of radar reflectivity data in the CWSU represents a significant step forward in improving the accuracy of weather data available for ATC. However, it will be shown in the next section that the greatest benefit in terms of increased safety and reduced delays lies in providing significantly enhanced weather products in the terminal areas.

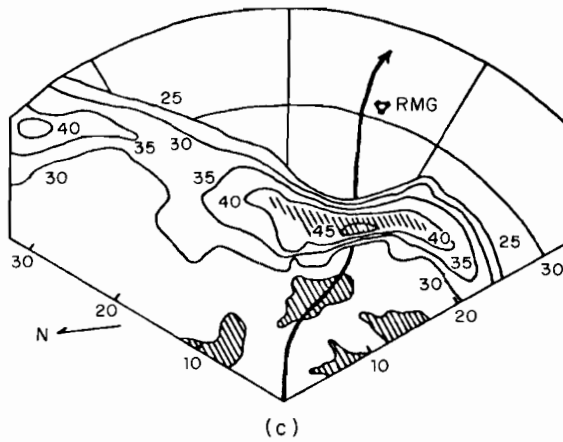
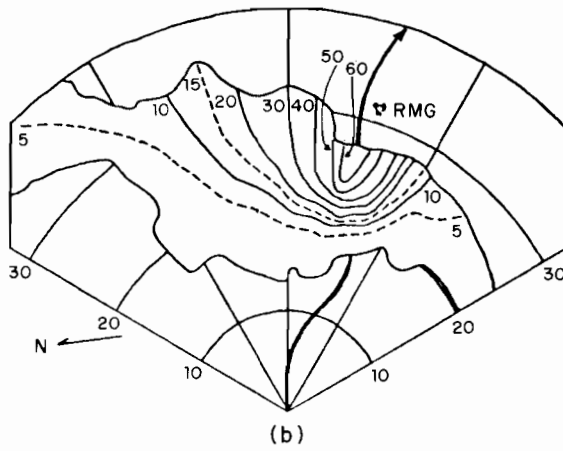
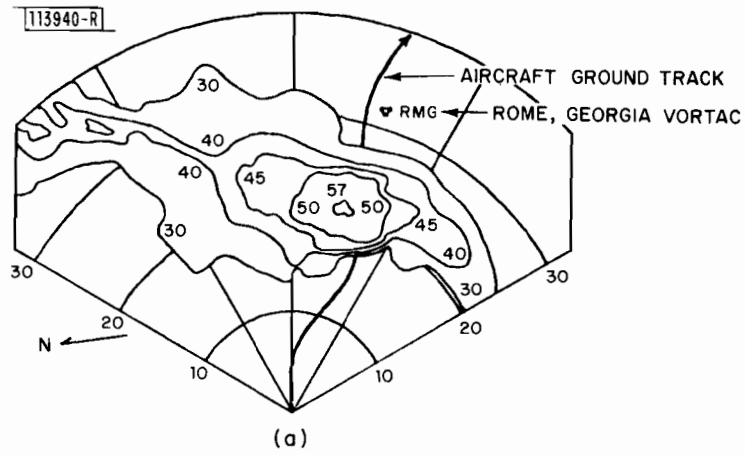

Fig. 1.4. Illustration of airborne weather radar reflectivity bias due to attenuation.

In summary, it can be said that the present system for providing weather services to aviation is, from an operational point of view, clearly most deficient in terms of the accuracy and timeliness of information available in the terminal and airport airspace. In particular:

1. Radar reflectivity alone is not an adequate indicator of certain hazards associated with thunderstorms, particularly turbulence (at all altitudes) and low level wind shear.
2. The quality of the broadband reflectivity information from ASR's may be insufficient to support tactical operations in the airport and terminal airspaces.
3. In order to significantly improve safety and efficiency in the terminal and airport airspace, the most recent advances in Doppler radar meteorology should be incorporated into new terminal area sensors to provide products which delineate hazardous airspace to the controllers and pilots.

B. Statistics on Aviation Hazards and System Efficiency

It is possible to justify an FAA investment in improved radar meteorology in two principal ways. A more effective weather radar system will bring about a reduction in the rate of weather-related air crash disasters, while simultaneously reducing air carrier operating costs due to weather delays. To gain some impression of the annual cost to air traffic operations of hazardous weather, we review some accident and operating statistics.

The National Transportation Safety Board investigates both Commercial Carrier (CC) and General Aviation (GA) accidents, and compiles separate yearly statistical summaries for both categories of aviation.[32-37,39] From these documents it is possible to determine how significant weather is as a factor in causing accidents, and also which weather conditions are statistically the most hazardous. The type of improved weather service that would be most effective in reducing injury and loss of life is then more easily identified.

During the 12 years from 1967-1978, the total number of GA hours flown increased nearly 80% from 22 million to 39.4 million. The total number of accidents increased at about the same rate. Table 1.1 summarizes some of the accident statistics for the three years 1976-1978. The number of accidents involving weather as a cause/factor remained relatively constant at about 21%. The percentage of fatal accidents involving weather was higher, averaging almost 40%.

Table 1.2 is a summary of some statistics on the weather-related GA accidents, compiled from references 35, 36, and 37. Visibility as a cause/factor includes any weather-related obstruction to vision, such as fog, or low

TABLE 1.1
GENERAL AVIATION ACCIDENT STATISTICS, 1976-1978

	<u>1976</u>	<u>1977</u>	<u>1978</u>
G.A. Hours Flown (Million)	36.13	38.60	39.41
Accidents (All Causes)	4193	4286	4494
Weather-related Accidents	908	952	928
Fatal Accidents (All Causes)	695	702	793
Weather-related Fatal Accidents	262	258	322
Fatalities (All Causes)	1320	1436	1770
Weather-related Fatalities	601	608	759

TABLE 1.2
WEATHER-RELATED GENERAL AVIATION ACCIDENTS, 1976-1978

Compiled from References 35, 36, 37. See Comments in text.

<u>Accident Cause/Factor</u>	<u>Fatal Accidents C/F</u>	<u>Non- Fatal C/F</u>	<u>All Accidents C/F</u>	<u>TOTAL</u>
Visibility	7/797	4/373	11/1170	1181
Wind Shear	14/88	202/966	216/1054	1270
Precipitation	0/264	3/157	3/421	424
Turbulence in T-storms	9/44	3/24	12/68	80
Turbulence in Clear Air	2/9	6/18	8/27	35
Thermal/Density Anomalies	2/77	3/255	5/332	337
Other	4/100	27/229	31/329	360

ceiling. The category other includes accidents caused by icing, whirlwinds, tornadoes, lightning strikes, and miscellaneous accidents listed by the FAA as other. The factor total for all accidents exceeds the total number of weather-related accidents because some accidents involve multiple factors.

The following conclusions may be drawn from these tables:

1. Wind shear and reduced visibility are by far the most common weather hazards to GA, each being a factor in over 40% of all weather-related accidents.
2. Precipitation, the next most important hazard, is only a factor in 15% of all weather-related accidents.
3. Turbulence of all types is a cause/factor in less than 5% of all reported weather-related accidents.
4. The turbulence statistics are misleading in the sense that there are probably many extremely uncomfortable GA flights which do not end with reported injuries or accidents.

During the eight years from 1971 through 1978 the total number of CC hours flown varied from a low of 5.98 million (1974) to a high of 6.79 million (1978). The yearly accident total decreased steadily over this period from 71 to 24. During the years 1976-1978 there were 28, 26 and 24 accidents reported. Since there are so few total accidents, it is possible to read all of the briefs, and produce a summary of the cause/factor relationships. This is done in Table 1.3.

The table indicates that 29 of the 78 accidents were weather-related, and that 80% of these were the result of encounters with turbulence in the en route air space. Although some of the 23 turbulence accidents involved significant injury, there were no fatalities. Furthermore, in all but two of the accidents, the seat-belt sign was illuminated, and the injured person was not wearing a seat belt.

The six remaining weather-related accidents are divided evenly between cruise altitude precipitation, low level wind shear, and reduced landing visibility. In both of the reported visibility accidents, the pilots failed to follow the approved procedures, e.g., descent rate and altitude were not monitored; altitude callouts were not provided by the copilot.

The FAA has evolved well established, effective procedures for low visibility landing situations and weather detection is not really the problem for this class of accident.

The accident data for 1976-1978 suggest then that the two most significant weather hazards to CC aviation are: encounters with low level wind shear on takeoff or landing, and stalling of engines as a result of penetration into hail cores or very heavy rain cells at cruise altitude.

TABLE 1.3
SUMMARY OF COMMERCIAL CARRIER ACCIDENTS, 1976-1978

Compiled from References 32, 33, 34.

<u>Accident Type</u>	<u>No. Accidents</u>	<u>Injuries Fatal/Serious</u>
Tenerife (1977)	1	575/33
Non-Weather Related	48	211/127
Weather-Related	29	78/118
Cruise Altitude Precipitation	2	74/23
Cruise Altitude Cat	9	0/9
Cruise Altitude Turbulence in T-storm	14	0/28
Low level Wind Shear	2	0/36
Landing Visibility	2	4/22
 TOTALS, ALL ACCIDENTS	 78	 864/278

Table 1.4 is a partial list of CC accidents occurring from 1973-1980, caused by one of these two hazards. No claim is made as to its completeness, but it accounts for the loss of some 238 lives, 93 serious injuries, 6 large jet aircraft destroyed, and 2 substantially damaged. Beyond the obvious cost of about \$160M to replace the aircraft, there are substantial costs associated with the law suits generated by these accidents. Survivors and next of kin file suit against the air carrier and the Federal Government. The airline also files suit against the government, claiming controller negligence.

The Eastern 66 accident at JFK is typical. The airline and the Federal Government settled out of court for roughly \$28M, with the largest individual settlement being \$1.2M.^[22] The more recent Southern 242 crash in Georgia is still in litigation, with damage settlements expected to exceed \$.5M per individual. The average annual cost to society of these two types of CC accidents may thus be assessed at \$35M to \$40M.

From the foregoing accident statistics it may be concluded that:

1. For CC traffic, en route turbulence is an unpleasant nuisance, but other phenomena are significantly more hazardous.
2. The two major sources of hazard are: (a) unusually heavy precipitation cells encountered at any altitude, and (b) low altitude wind shears encountered on landing or takeoff.
3. Cruise altitude precipitation is not so serious a problem for GA pilots because they avoid it. Many are restricted to VFR operation, and many who are IFR-rated avoid it by choice.

Table 1.5 is a summary of some published ATC delay statistics for delays in excess of 30 minutes. These statistics have been compiled by the FAA for the years 1971-1974.^[40] Weather is the dominant cause of such delays, the majority of which are arrivals delayed in the terminal airspace. In the present system, a reduction in the acceptance rate at any major airport propagates into a backlog in the en route airspace, and eventually results in departing flights being held on the ground at other airports. During a test of the FAA fuel advisory and departure procedure in 1976, Chicago-bound flights were held on the ground at 150 airports until they could be accepted at O'Hare International Airport with little or no airborne delay. The FAA estimated that this procedure saved some 658,000 gallons of fuel in a single day.^[41]

Such procedures depend, for efficiency, on the availability of accurate short-term forecasts of terminal area weather conditions. GA pilots and dispatchers for the air carriers can then decide prior to scheduled departure time whether to cancel, hold, or alter their flight plans to divert to a clear terminal.

Severe weather in the en route airspace has a less dramatic but still non-negligible impact on efficiency. The present system uses strategic

TABLE 1.4
 PARTIAL LIST OF CC ACCIDENTS OCCURRING FROM 1973-1980,
 CAUSED BY ENCOUNTERS WITH EITHER LOW-LEVEL WIND SHEAR
 OR CRUISE-ALTITUDE PRECIPITATION

<u>CC LLWS Accidents</u>				
<u>FLIGHT</u>	<u>DATE</u>	<u>LOCATION</u>	<u>FLIGHT PHASE</u>	<u>INJURIES FATAL/SERIOUS</u>
Ozark 809	23 July 73	Lambert-St.Louis International	Landing	38/6
Iberia	75	Logan International	Landing	?
Eastern 66	24 June 75	JFK International	Landing	113/11
Continental 426	7 Aug 75	Denver-Stapleton International	Takeoff	0/15
Eastern	Nov 75	Raleigh, N.C.	Landing	?
Allegheny 121	23 June 76	Philadelphia International	Landing	0/36
Continental	3 June 77	Tucson Intern'l	Takeoff	0/0
Eastern 693	22 Aug 79	Atlanta-Harts- field Int'l	Landing (Near Crash)	0/0
<u>CC Precipitation Accidents</u>				
Kodiak Western	7 Mar 76	Igiugig, Ak.	Cruise	4/0
Southern 242	4 Apr 77	New Hope, GA	Cruise	70/23
Air Wisconsin 965	12 June 80	Valley, NB	Descending Approach Control	13/2

TABLE 1.5
ANNUAL ATC DELAY STATISTICS

	Percentage of ATC Delays in Excess of 30 min.			
	1971	1972	1973	1974
	%	%	%	%
Total Weather	89	89	74	64
Below Minimum	28	17	17	15
Low Ceiling/Visibility	13	13	15	9
Thunderstorms	17	17	15	21
Snow/Ice	11	21	9	10
Wind	11	13	12	7
Non-specific	9	8	6	2
<hr/>				
FAA Equipment	2	3	5	6
Airport/Runway Closure	4	3	14	14
Volume	3	3	5	14
Other	2	2	2	2

routing procedures such as the Severe Weather Avoidance Plan (SWAP) devised for the New York ARTCC: a joint decision is made by the Center Weather Service Unit (CWSU) meteorologist and the Flow Controller to divert en route traffic to an alternate set of routes on the basis of a two-hour forecast*. This planning is strategic in nature, and it results in larger deviations than necessary because of the conservative weather separation standards that must be followed in the absence of more accurate weather information.

The accident and delay statistics presented in this section illustrate the point that the majority of weather-related incidents occur in airport/terminal as opposed to en route airspace. Beyond the obvious fact that aircraft of all types are more susceptible to meteorological hazards during landing and takeoff, it is clear that the existing system can be most improved in the quality and timeliness of weather information provided in the airport areas. Contributing factors include:

1. Pilot and crew are frequently too busy preparing the aircraft for landing/takeoff to give careful attention to cockpit weather instruments.
2. Certain hazardous phenomena, e.g. wind shears, may form, evolve, and dissipate on a time scale of minutes.
3. Air Traffic Controllers can only advise and warn; ultimately it is the pilot who must react, or exercise judgment. The need for cockpit information is clear.
4. Shortcomings of presently instrumented Low Level Wind Shear Alert System (LLWSAS): these systems are not able to detect a wind shear on the glide slope beyond the ILS middle marker location.

C. Identification of Weather Surveillance Requirements and Products

The statistics and operational procedures discussed in the preceding sections compel the general conclusion that improved weather services would have a significant impact on air traffic safety and would lead to a reduction of transportation costs. At a minimum, the FAA needs a weather information system that:

1. Detects and tracks areas of intense precipitation, and provides information on their vertical extent in all airspace.

*Uncertainties in the knowledge of storm dynamics may in some cases limit the application of weather radar data in making two hour forecasts.

2. Detects and (to the extent that this is possible) tracks areas in the airport airspace of low-level wind shear and turbulence, regardless of the amount of precipitation present.
3. Detects areas of severe turbulence associated with thunderstorms at all levels, including the en route airspace, if possible.
4. Extrapolates the above data to aid in planning operations.

ARTCC, FSS, and TRACON personnel would use this information in different, but consistent ways, in order to obtain maximum benefit from improved weather detection. Some of these differences are summarized in Table 1.6. The discussion below provides further details.

1. En Route Usage

A CWSU meteorologist would use weather radar products primarily for strategic and advisory purposes: to aid him in making intermediate term forecasts, in issuing advisories on Service B, and in making decisions about when and how to implement severe weather avoidance plans. The data rate and format that would be used by this meteorologist presumably would be similar to that to be used by the NWS meteorologists and hence would not dictate any FAA unique NEXRAD requirements.

A sector controller in the ARTCC would want to have access to the tracked precipitation and severe turbulence data in a simple format which is consistent with his traffic display. The information would be used primarily for advisory purposes in control of aircraft. It would also aid him in handling intelligently any pilot requests for deviations around hazardous weather (fewer false safes). Furthermore, the controller would be able to anticipate encounters with weather hazards and minimize them with minor route deviations.

The advantages offered by having reliable strategic weather information in the en route centers and flight service stations would include:

1. Increased efficiency and economy of operation for commercial carriers.
2. Significant reduction in flights scheduled by GA pilots to check the weather conditions.
3. Significantly safer, more reliable planning and operations for GA pilots.
4. Increased credibility for ATC weather services, and
5. Greater safety in the use of airborne weather radar to avoid weather on a short duration basis (by warning pilots of conditions in which the airborne display may be misleading).

TABLE 1.6

WEATHER AND WEATHER AVOIDANCE IN THE EN ROUTE AND TERMINAL/AIRPORT AIRSPACES

	EN ROUTE	TERMINAL/AIRPORT
SERIOUS HAZARDS	HEAVY PRECIPITATION CELLS	LOW VISIBILITY WIND SHEAR HEAVY PRECIPITATION CELLS TURBULENCE
FORECASTING	DAILY WITH HOURLY UPDATES	HOURLY WITH MORE FREQUENT UPDATES IN SEVERE WX
AVOIDANCE	STRATEGIC AND TACTICAL	TACTICAL
AVOIDANCE MANEUVERS	AROUND OR POSSIBLY OVER	AROUND ONLY
REACTION TIMES	MINUTES	SECONDS TO MINUTES

2. Terminal Usage

The operations statistics for large airports such as LaGuardia reveal that thunderstorm activity has only a minor effect on the operations staged per hour^[38]. In order to maintain flight schedules pilots sometimes use runways under conditions that turn out to be hazardous^[26-30].

Some members of the ATC community hold the view that it is not desirable for controllers to use weather information to give tactical, needle-threading vectors to aircraft. Nonetheless, it is technologically feasible to provide accurate high-update-rate weather information in the airspaces surrounding large metropolitan airports.

Achieving increased safety and throughput factors at major airports will necessitate not only higher update rates, but also higher resolution coverage than that required in most of the enroute airspace, in order to insure detection of wind shear hazards.

The statistics which point to low level wind shear (LLWS) as a primary airport hazard have not gone unnoticed by either the FAA or the NTSB. The FAA has sponsored research on both ground-based and airborne wind shear alert systems^[42]. The NTSB has expressed concern that no airborne gradient detecting sensor will be adequate. A formal directive on this question was issued in response to the Eastern 693 LLWS incident at Atlanta-Hartsfield (1979). It reads in part:

A Low Level Wind Shear Alert System [anemometer array] was developed and placed in operation at several major airports. The system represented a step forward; however, as shown by the circumstances of this incident, the system contains several shortcomings. An area of prime concern remains the inability of the ground detection systems to detect a wind shear above and in the vicinity of an airport and then to furnish up-to-date quantitative measurements of the motion of air within that wind shear.^[26]

A controller operating in the TRACON should have access to highly accurate, real time measurements of precipitation and wind shear conditions along all active approach and departure corridors. In addition, he should be able to access more global information on all tracked precipitation and turbulence features in the airport airspace. Such information would be used to provide accurate advice and warnings to pilots attempting both landings and take-offs. If, as anticipated, the accuracy of such information should become widely recognized, criteria could be established for temporary closure of runways, similar to those now in use for visibility minimums.

D. Impact on Present ATC Operations

It is pointed out in Section II that the present capabilities of radar technology are not adequate to support separation of aircraft from hazardous

weather features 100% of the time. Even if the technology were available, there are operational limitations which can only be removed via policy changes.

The FAA Air Traffic Control Handbook describes the formal procedures to be followed by ATC's. Operational procedures are highly formalized, and the controller's duties and obligations are very carefully spelled out. These duties are assigned priorities; in the event of controller overload, performance of high priority duties overrides any obligation otherwise assumed to provide lower priority services. The first priority is always to maintain separation of aircraft. Handling of pilot reports and dissemination of weather information to pilots is currently considered to be a third priority service, and is entirely discretionary^[20]. The provision of these services obviously adds to the ATC work load.

The controllers and the Federal Government alike have ample reason to be concerned about changes to the system which may expose them to increased liability while not simultaneously providing them with a tool that is 100% effective. Virtually every weather-related air crash disaster generates a significant amount of litigation. The court decisions in such cases are not entirely consistent, but there has been a clear trend in the past decade: the Federal courts have significantly expanded the tort liability of the government in weather-related air crash disasters. Case law precedents have been established in which the Federal Government is held liable for the negligence of ATC's (acting as its agents) in failing to transmit weather information^[21]. Even more disturbing, an individual controller has been named as a defendant in at least one suit^[22]. (A comprehensive review of the subject is beyond the scope of this paper, but the interested reader is referred to references 13, 15, and 21.)

In proposing the concept of an advanced weather information system it is recognized that availability of improved weather products must not detract from the controller's primary responsibility for maintaining aircraft separation. Individual controllers must retain freedom to select the most appropriate display contents. The introduction of accurate real-time weather data would reduce the number and impact of unexpected pilot requests for deviations. The system should support an enhanced common understanding of the weather situation for mutual pilot-controller benefit. Ultimately, condensed weather information from the ground-based sensors could be uplinked directly to the pilot via data link*.

* For example, via the Beacon Mode S data link ^[61] or via the VOR voice channel^[62].

II. FAA WEATHER REQUIREMENTS AND RADAR METEOROLOGY

A. FAA Weather Requirements as Specified to NEXRAD JSPO

In December 1979, the FAA provided to the NEXRAD JSPO a description of the weather detection services required for air traffic control^[24]. This functional requirements document assumes for the sake of discussion that detection and measurement of a very broad spectrum of weather phenomena may be possible with weather radar. Coverage and siting limitations of the existing NWS radar network are not considered in this context.

The FAA requirements are expressed in three different ways:

1. By specification of a minimum resolution, accuracy, and update rate to be maintained in covering each of three different surveillance volumes.
2. In terms of detection of specific meteorological phenomena, and the measurements desired for each.
3. In terms of maximum allowable estimation errors for each of the three primary doppler radar observables: reflectivity, radial velocity, and spectrum width.

Table 2.1 summarizes the coverage requirements for the en-route, terminal and airport airspaces. The en-route airspace extends over the entire continental U.S. (CONUS), and outward for 125 nmi from the coast. Terminal coverage from 0 to 56 km is required in the airspace surrounding 76 airports specified by the FAA (see Appendix A). The first 40 airports on the list also require airport coverage out to 20 km.

Table 2.2 is a matrix which tabulates the attributes to be determined for each of 11 meteorological phenomena. Attribute definitions are given in Table 2.3. With the exception of the low-level wind field, detection of all phenomena is desired in all three airspaces. Low-level winds, and most particularly wind shears are to be measured in the airport airspace, along approach and departure corridors in precipitation and clear air.

Table 2.2 has been constructed from a review of FAA requirements as enumerated in references 24 and 25. Some of the attribute definitions chosen here deliberately imply a particular type of product, e.g., horizontal boundary is defined in terms of contours, suggesting that the presentation might be in the form of a contour map. The advantage of formulating things in this manner is that it allows the attributes to be grouped according to the level of computational complexity required to obtain them. In particular, the term base data, as used in the Joint Operational Requirements document [25] is here assumed to include only radar observables. The distinction between base data and derived data is thus conveniently viewed as a distinction between the results of signal processing and those of data processing. The

TABLE 2.1
 FAA REQUIREMENTS FOR WEATHER RADAR COVERAGE, RESOLUTION, ACCURACY
 AND UPDATE RATES
 SOURCE: REFERENCE [24]

AIRSPACE	MAXIMUM RANGE EXTENT	ALTITUDE EXTENT	RESOLUTION VOLUME	LOCATION ACCURACY	FULL VOLUME SURVEILLANCE TIME
EN ROUTE	96 nmi (178 km) Up to 140 nmi (260 km) to cover adjacent cone of silence	6KFT to 70KFT AGL MSL 13 KFT is best obtainable min. at 140 nmi	x,y,z: 3050m	x,y: 750m z: 610m	5 minutes, maximum, with a decimated version of the volume covered every 2.5 minutes.
TERMINAL	Within 30 nmi (56 km) Radius of Given Terminal Locations	500FT AGL to 20KFT MSL	x,y,z: 1000 m	x,y: 250m z: 305m	5 minutes, maximum with a decimated version covered every 2.5 minutes.
AIRPORT	Within 10.8 nmi (20 km) Radius of Given Airport Locations	200FT AGL to 10KFT MSL	x,y,z: 365m	x,y,z: 90m	5 minutes maximum, with a decimated version covered every 2.5 minutes

TABLE 2.3
SOME ATTRIBUTES OF METEOROLOGICAL PHENOMENA, WITH DEFINITIONS

BASE DATA (Measured or estimated for a particular range, azimuth, elevation cell)

1. REFLECTIVITY - Radar Reflectivity
2. RADIAL VELOCITY - Radar Doppler velocity, first moment of spectrum.
3. SPECTRUM VARIANCE - Second moment of spectrum.
4. MEASURED LOCATION - Location of radar range-azimuth-elevation volume (x,y,z) in which measurement was performed.

DERIVED DATA

1. HORIZONTAL EXTENT - Horizontal boundary contours.
2. VERTICAL EXTENT - Vertical boundary contours. In some cases, maximum and minimum alphanumeric is sufficient, e.g., echo top height.
 - (a) top
 - (b) bottom
3. PRECIPITATION
 - (a) rate - in mm/hour.
 - (b) cumulative - in mm.
4. TYPE - Alphanumeric information which varies from weather phenomenon to phenomenon.
5. "POINT" VELOCITY (Radar Resolution Cell) - Wind velocity contours in Cartesian coordinates, possibly derived from radar velocity measurements of two or more radars. (Radar Resolution Cell)
 - (a) horizontal
 - (b) vertical
6. "POINT" WIND SHEAR Wind shear contours in Cartesian coordinates, possibly derived from spectrum variance measurements of two or more radars.
 - (a) horizontal
 - (b) vertical
7. CENTROID LOCATION (x,y,z) - Estimated Cartesian center of some tracked special pattern.
8. CENTROID HORIZONTAL VELOCITY - Estimated horizontal velocity of some tracked special pattern. Derived from having the pattern under track--not to be confused with "point" velocity.
 - (a) area/cell (closed contour)
 - (b) line
9. TRACKED Δ REFLECTIVITY - Change in max radar reflectivity of some special pattern under track, from last tracker update.

TABLE 2.3 (Continued)

10. TRACKED AREAL GROWTH RATE - Estimated rate of growth of horizontal and vertical boundaries of a tracked special pattern.
 - (a) horizontal
 - (b) vertical
11. TRACK DURATION - Time that special pattern has been in track.
12. TRACK POSITION PREDICTION - Extrapolation of present centroid location of a tracked special pattern to its predicted location at a specified future time.
13. CELL ROTATION - Estimate of the horizontal rotation rate (in seconds⁻¹) of a tracked special pattern.
14. CONVERGENCE/DIVERGENCE - Qualitative estimate of the net flux into or out of the volume occupied by a tracked special feature.
15. MAXIMUM REFLECTIVITY - Estimate of the maximum reflectivity of a tracked special pattern.

PHENOMENA

1. Fine Lines - Phenomena associated with air mass boundaries. These include gust fronts, low level wind shear, boundary layer mesoscale discontinuities, and clear air phenomena along an approach guide slope [60].

derived data may be further categorized as belonging to: (a) an intermediate level which requires contouring, feature extraction, and/or pattern recognition; or (b) a more sophisticated level which requires one or more of the intermediate products, and performs tracking as well. These groupings are indicated in the table.

The FAA has a requirement for all three levels of products, although they would be seen and used by different members of the ATC system.

Typically the pixel maps of reflectivity, velocity, and spectrum width might be useful to the CWSU meteorologist in an en route center. The Atlanta ARTCC has been using reflectivity information in DVIP format from three adjacent NWS radars to aid in making forecasts and strategic rerouting decisions.

The more highly processed products such as tracked reflectivity and turbulence features would be used by individual controllers to make decisions about their traffic.

The FAA requires reliable automated weather products for both en route (strategic) and terminal (tactical and strategic) operations. Weather products must be provided with very low probability of false alarm (P_{fa}) and high probability of detection (P_d). Acceptance of the system depends crucially on the credibility of the highly condensed outputs presented to controllers and/or pilots.

A weather information system based on radar meteorology must take maximum advantage of the capabilities of the coherent radar sensor. At the same time, it is important to realize that this technology introduces some special problems, many of which are familiar to the FAA through its work in radar technology for ATC. Experience gained with operational systems has shown that a real time radar data base will contain numerous erroneous data points caused by ground clutter, ground vehicular traffic, air traffic, anomalous propagation, birds, etc. [50].

The baseline NEXRAD design (per NTR-workshop) will require radar meteorologists to intervene manually in an attempt to censor these anomalies. While it is highly desirable to allow experienced meteorologists to annotate the data base, the system cannot depend on this input for reliable operation. In severe storm situations this strategy will fail. It may be adequate for NWS and AWS purposes, but is unacceptable for air traffic control.

Although the measurement or derivation of an attribute for a particular Table 2.2 phenomenon defines a potential weather radar product, it is important to realize that not all such potential products can be reliably generated. In the next section, some comments are offered on the feasibility of providing the individual products that have been specified.

B. Comments on the State-of-the-Art in Radar Meteorology

Most of the weather phenomena listed in Table 2.2 are embedded in precipitation of some kind. In the presence of hydrometeors, the radar reflectivity, expressed in units of dBz (decibels corrected for range) may vary by more than 50 dBz, depending on the type and rate of precipitation. In fact, this variation tends to be a measure of the rainfall rate. However, the single pulse signal-to-noise ratio (SNR) for precipitation echoes is typically in excess of 15 dB at ranges out to 250 km for a NEXRAD like radar. Clear air turbulence and gust fronts, because they do not occur in precipitation, present very low radar reflectivity, (low SNR, typically less than 0 dB even at close range) and thus are much harder to detect at radar frequencies.

This large difference in SNR which distinguishes clear air phenomena from those embedded in precipitation can be expected to have a significant impact on the design and operation of any radar-based detection system. The most obvious effect is that longer dwell times are required to obtain satisfactory Doppler measurements of clear air phenomena. Some of the pertinent information is summarized in Table 2.4.

1. Turbulence in Presence of Precipitation

It can be shown that, in the absence of clutter and noise, the observed signal spectrum from a radar pulse volume containing hydrometeors (which move with the wind) is a replica of the probability distribution for their radial velocity. Under the additional assumption that the volume is completely filled with isotropic turbulence in the inertial subrange (typically, a scale size less than 1 km), a theoretical relationship between the turbulent dissipation factor, ϵ , and the spectrum width, σ_v , may be derived [9]:

$$\epsilon^{1/3} = C \sigma_v / R^{1/3}$$

where C is a constant determined by the shape of the radar pulse volume, and R is the range to the volume. The buffeting experienced by an aircraft (see Figure 2.1) will be proportional to $\epsilon^{1/3}$, and thus proportional to the spectrum width measured by the radar.

Recent experiments have been performed at the National Severe Storms Laboratory (NSSL) and at the FAA Technical Center in an effort to demonstrate an empirical correlation between aircraft-based measurements of $\epsilon^{1/3}$ made while flying through turbulent regions of thunderstorms, and simultaneous radar measurements of σ_v in the surrounding air space [44].

Figures 2.2 and 2.3 show data from a storm penetration made by an armored T-28 aircraft near Norman, Oklahoma on 20 May 1980. The storm area was bar scanned by the NSSL Doppler radar, using 4 elevation cuts over 100° of azimuth, which bracketed the aircraft flight path. Each elevation cut took approximately 26 seconds, and the entire pattern was repeated every 110

TABLE 2.4
RELATION OF RADAR OBSERVABLES TO PRINCIPAL METEOROLOGICAL PHENOMENA

	RADAR OBSERVABLE	REQUIRED ACCURACY	REQUIRED DWELL TIME	METEOROLOGICAL PHENOMENA	STATUS OF RADAR METEOROLOGY
IN PRECIPITATION	REFLECTIVITY	1 dBz	60 ms (30 SAMPLES)	RAIN, HAIL, BRIGHT BAND	1) RELIABLE ESTIMATES OF RAINFALL RATE. 2) HAIL DISCRIMINATION POSSIBLE, BUT NOT 100%. 3) DETECTION OF BRIGHT BAND USED TO DETERMINE FREEZING/MELTING LEVEL. 4) WIND FIELD CAN BE DEDUCED WITH SINGLE SENSOR UNDER CERTAIN HOMOGENEOUS CONDITIONS. 5) EARLY DETECTION OF TORNADO VORTEX SIGNATURES HAS BEEN DEMONSTRATED. 6) MODERATELY GOOD CORRELATION BETWEEN WIDTH & TURBULENCE HAS BEEN OBSERVED IN THUNDERSTORM PENETRATIONS. LIMITATIONS: PROBLEMS WITH FALSE SAFES AND FALSE ALARMS. 7) RADIAL WIND AND SHEAR MEASURED IN LOW CLUTTER ENVIRONMENT USING DEDICATED SENSOR TO MONITOR GLIDE SLOPE. OPERATIONAL RELIABILITY NOT DEMONSTRATED. 8) LIMITED EXPERIMENTS IN LOW CLUTTER ENVIRONMENT HAVE BEEN PERFORMED, SUGGESTING SOME CORRELATION. OPERATIONAL RELIABILITY NOT DEMONSTRATED.
	RADIAL VELOCITY	1 m/s	150 ms	WIND, WIND SHEAR, TORNADOES	
	SPECTRUM WIDTH	1 m/s	150 ms	CONVECTIVE TURBULENCE	
CLEAR AIR	RADIAL VELOCITY	1 m/s	1.5 SEC	WIND, WIND SHEAR, GUST FRONTS	
	SPECTRUM WIDTH	1 m/s	1.5 SEC	CLEAR AIR TURBULENCE	

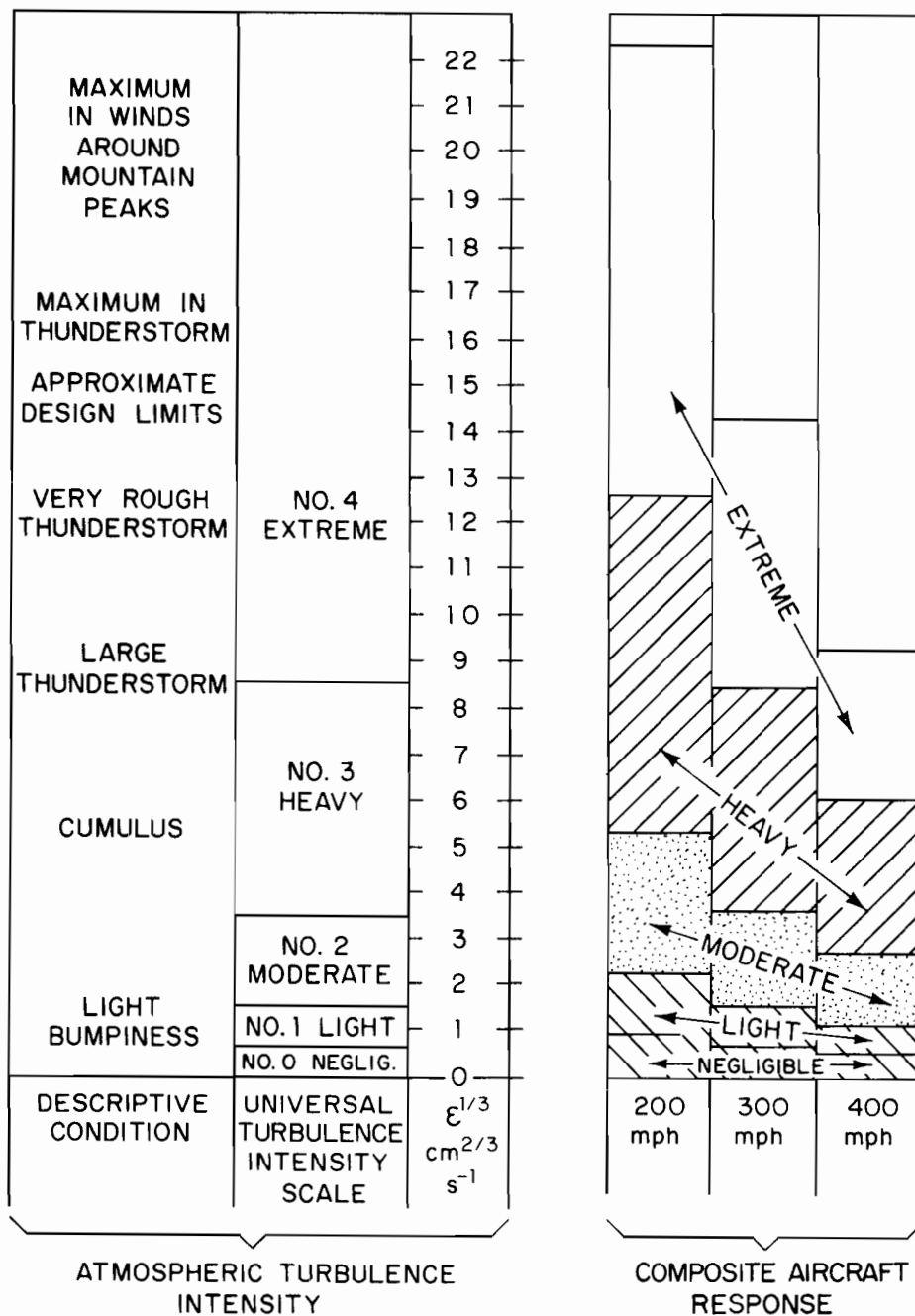
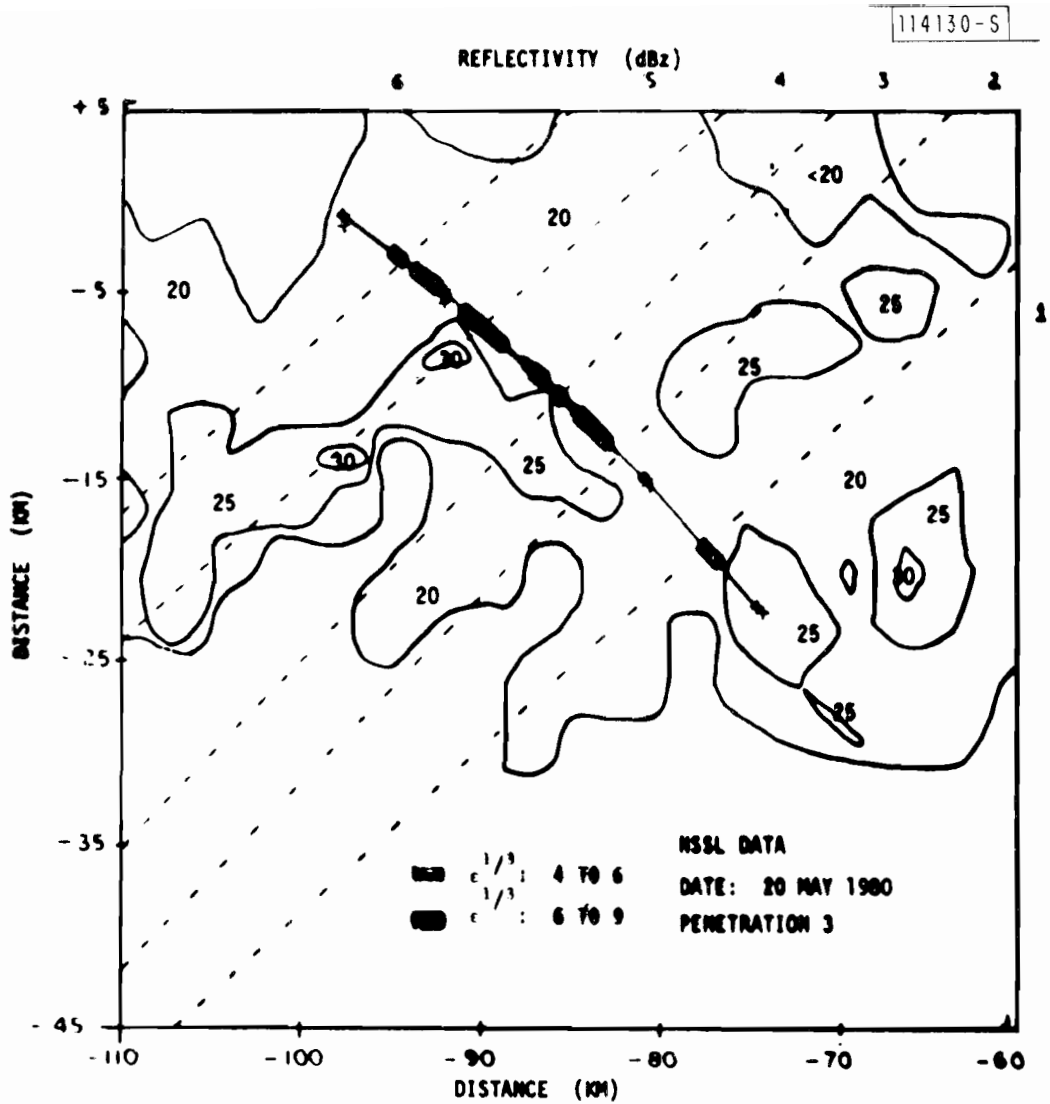
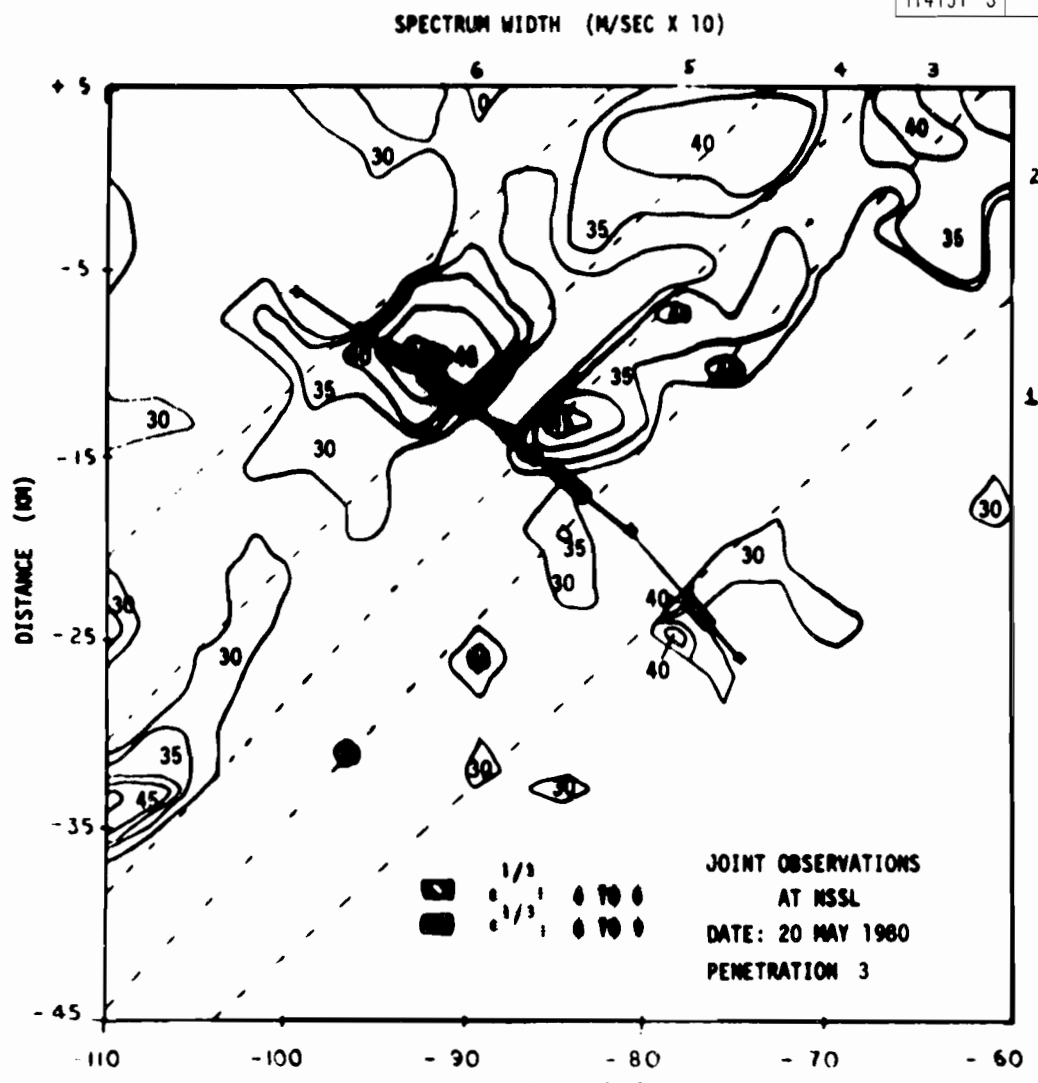

Fig. 2.1. Turbulence intensity scale relative to composite aircraft response.



SEGMENT #	SCAN START	RADAR EL ANGLE	PLANE EL ANGLE	PLANE TIME
1	10:53:26	2.86	2.8	10:53:56
2	10:55:15	2.87	2.7	10:55:36
3	10:56:35	2.11	2.6	10:56:40
4	10:57:03	2.89	2.4	10:57:20
5	10:58:23	2.12	2.3	10:58:29
6	11:00:11	2.12	1.9	11:00:21

Fig. 2.2. Reflectivity map of 20 May 1980 thunderstorm near Norman, Oklahoma.



SEGMENT #	SCAN START	RADAR EL ANGLE	PLANE EL ANGLE	PLANE TIME
1	10:53:26	2.86	2.8	10:53:56
2	10:55:15	2.87	2.7	10:55:36
3	10:56:35	2.11	2.6	10:56:40
4	10:57:03	2.89	2.4	10:57:20
5	10:58:23	2.12	2.3	10:58:29
6	11:00:11	2.12	1.9	11:00:21

Fig. 2.3. Spectrum width contour map of 20 May 1980 thunderstorm.

seconds. The composite xy contour maps of reflectivity, (I), and spectrum width, (σ_v) have been constructed by splicing together the appropriate strips from 6 separate scans, not all of which are at the same elevation. Because the aircraft elevation angle varied by nearly a beamwidth during penetration #3, contour data from the most proximate elevation cut was selected from each scan cycle. The contoured radar data thus represents a sector Constant Altitude Plan Position Indicator Display (CAPPI).

It can be seen in Figure 2.3 that the aircraft encountered significant turbulence ($\epsilon^{1/3} > 4$) during three intervals when it was flying through major σ_v features in the contour map. Note from Figure 2.2 that the width features are embedded in 20-25 dBz (relatively low) reflectivity regions. The SNR at this range is in excess of 23 dB. Generally, the intervals of turbulence correspond well to the spatial dimensions of the σ_v features, as defined by the 3 m/s contours. Complete point by point correlation is not overwhelmingly strong, but qualitatively, the result is encouraging.

Figures 2.4 and 2.5 show the I and σ_v contours from penetration #1 on the same storm. On this penetration, the correlation between turbulence and σ_v is not as good. Maximum turbulence is encountered while traversing a major width feature at approximately 10:19:30. However, note the presence of a false safe occurring at approximately 10:17:00 when the aircraft encountered turbulence factors between 4-6 for about 25 seconds, but spectrum widths in this region are all quite low, less than 2.5 m/s. (Figure 2.6 shows a grid of the σ_v values in a 4 x 4 km enlargement of this region.)

The term false safe is used to describe this situation because it would not have been possible, using a reasonable threshold value on radar-measured σ_v (say $\sigma_v = 3.5$ m/s) to predict that the aircraft would encounter turbulence. In fact, the area looks safe. As can be seen from Figure 2.1, the $\epsilon^{1/3}$ values actually encountered correspond to heavy turbulence, and an operational system could not tolerate this type of missed detection performance.

A reasonable conclusion from this type of data (see also ref.[44]) is that turbulence detection in precipitation on the basis of radar-measured σ_v has shown some encouraging results, but more research is required before this technique could be used in a reliable, automated operational system for ATC purposes.

2. Clear Air Turbulence and Wind Shear

Detection of clear air wind shears or turbulence in the absence of precipitation relies on scattering by dust, insects, and/or refractive index fluctuations^[59]. Clear air turbulence on a scale size comparable to the radar wavelength produces spatial inhomogenities in the refractive index which can be detected by radar. The refractive index fluctuations can be

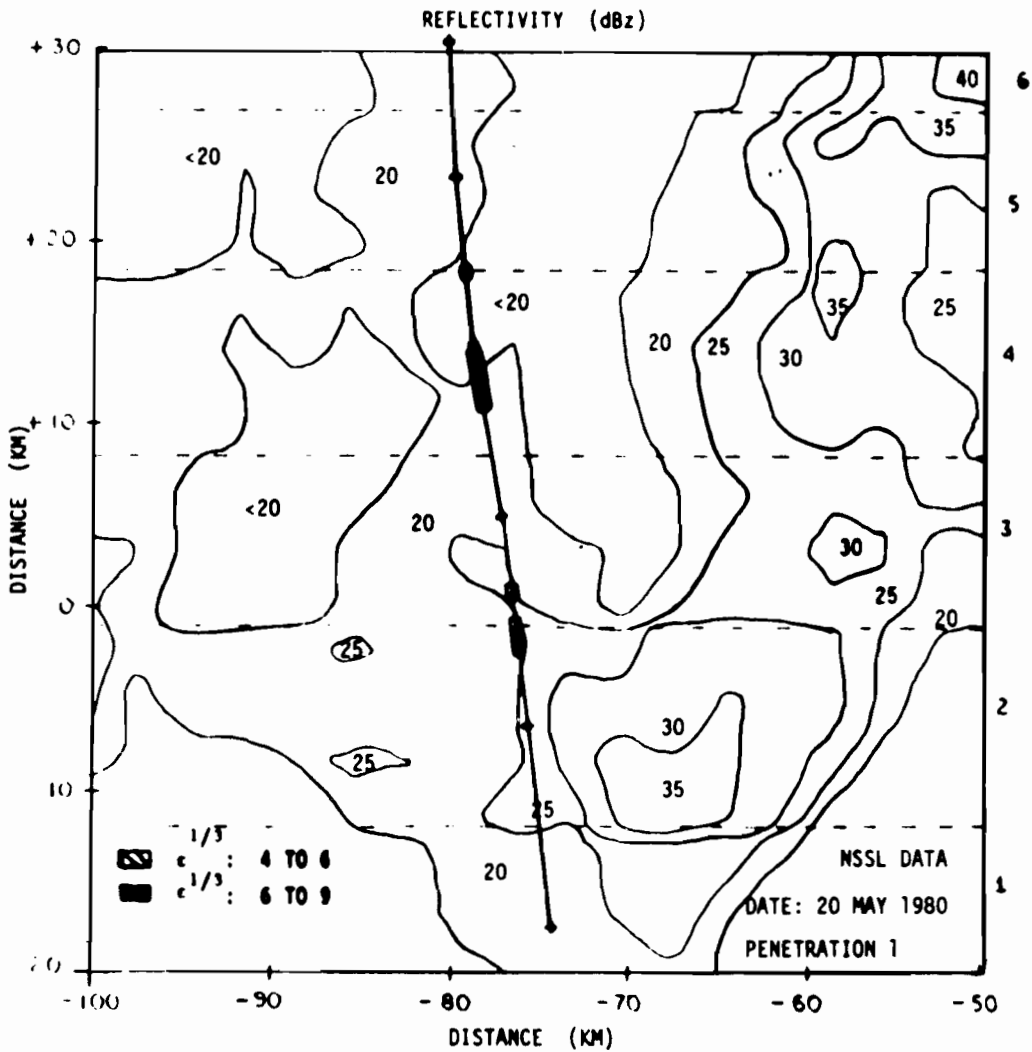

SEGMENT #	SCAN START	RADAR EL ANGLE	PLANE EL ANGLE	PLANE TIME
1	10:14:10	2.13	2.3	10:14:16
2	10:15:58	2.07	2.4	10:16:04
3	10:17:47	2.15	2.3	10:17:53
4	10:19:35	2.08	2.2	10:19:45
5	10:21:24	2.12	2.1	10:21:35
6	10:23:12	2.11	2.0	10:23:18

Fig. 2.4. Reflectivity contours and penetration of 1 for 20 May 1980 thunderstorm.

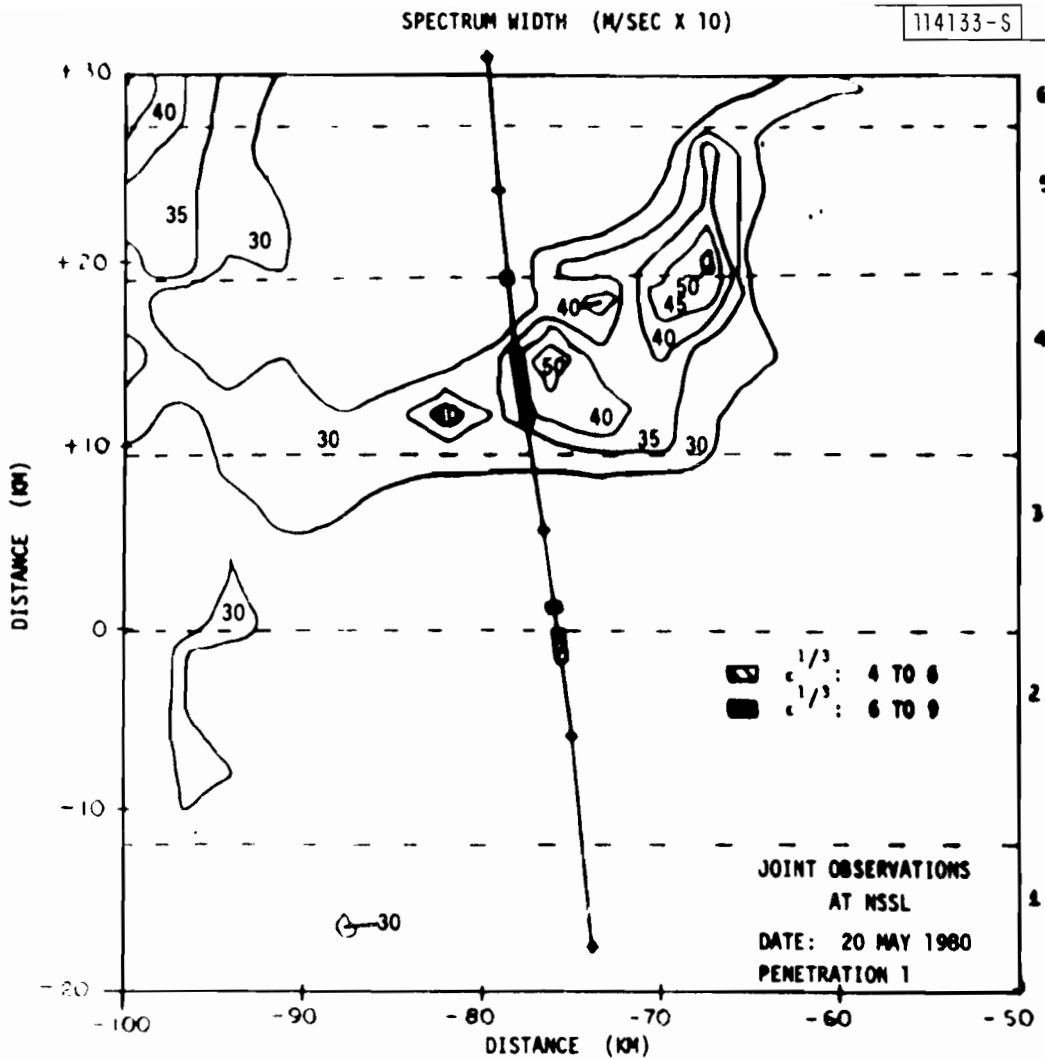

Fig. 2.5. Spectrum width contours and penetration 1 for 20 May 1980 thunderstorm.

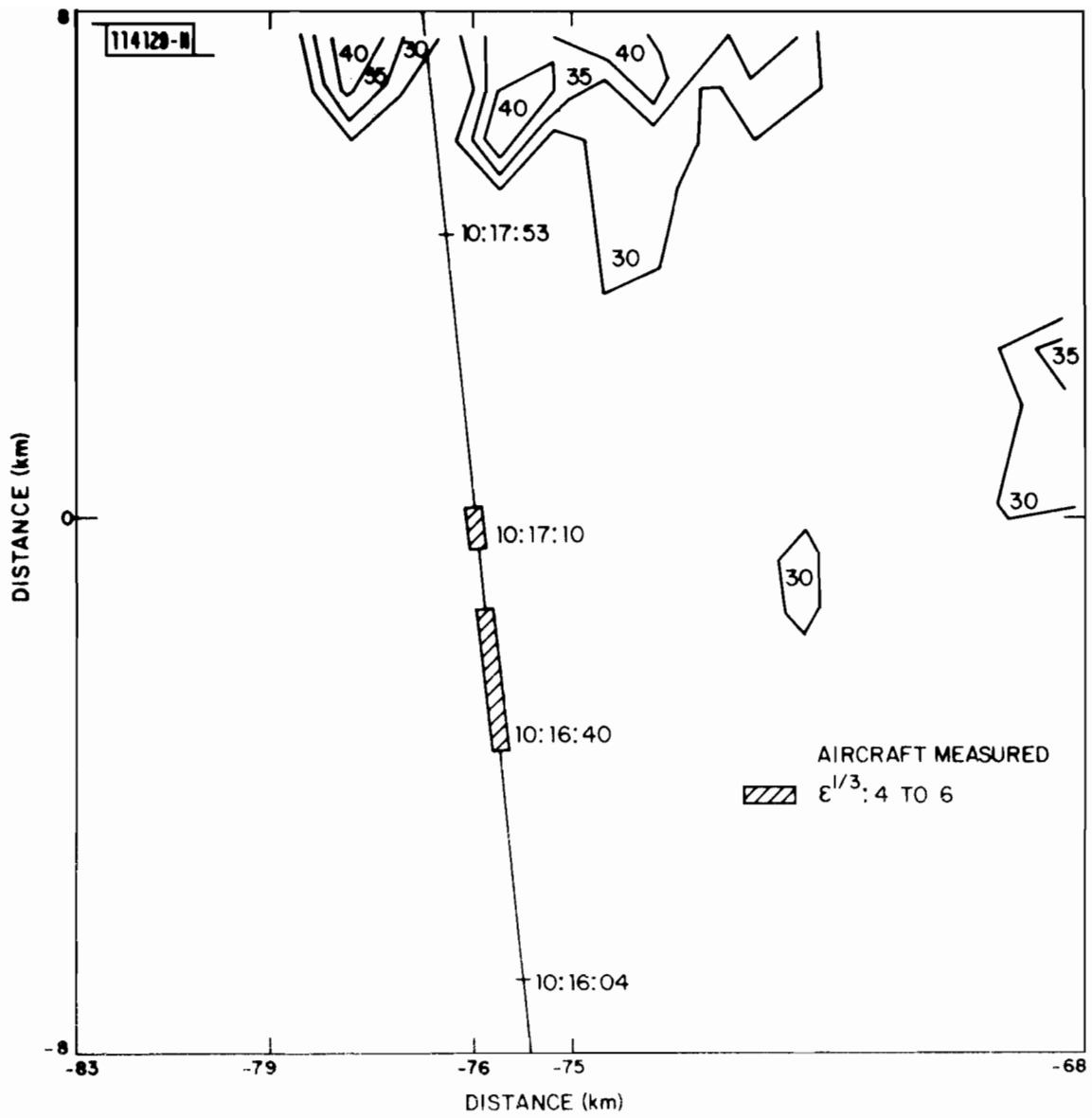

Fig. 2.6. Enlargement of false safe region of Fig. 2.5.

particularly pronounced near the ground in convective storm generation conditions due to sharp changes in the relative humidity. Values for C_n^2 , the refractive index structure function*, show a wide variation:

- (1) Gossard [53] suggests $4 \times 10^{-15} \text{ m}^{-2/3}$ for the boundary layer with maritime tropic air present (as on stormy days) increasing to $4 \times 10^{-14} \text{ m}^{-2/3}$ when solar heating is present at midday.
- (2) Doviak and Berger [54] suggest values as high as $5 \times 10^{-13} \text{ m}^{-2/3}$ on clear days in maritime air and a value of $4 \times 10^{-14} \text{ m}^{-2/3}$ as a nominal value on days when convective storms may arise.
- (3) Crane [55] observed C_n^2 values as low as $10^{-17} \text{ m}^{-2/3}$ below 15 km on 13 clear air days between January and July in New England.
- (4) Chadwick, Moran and Campbell[2] suggest a value of $3 \times 10^{-16} \text{ m}^{-2/3}$ for high plains location detection of down bursts or gust fronts and a value of $1.5 \times 10^{-15} \text{ m}^{-2/3}$ for the midwest and east coast.

The higher C_n^2 values appear to occur primarily in the prestorm convective boundary layer (CBL) which lies 0 to 1.5 km above the ground (AGL), although Doviak[56] indicates that very high values ($10^{-13} \text{ m}^{-2/3}$) can occur up to 5 km AGL.

Detection of gust fronts by reflections from refractive index inhomogeneities has been reported at ranges of up to 100 km, using dwell times on the order of 1 to 2 seconds[4,11]. However, reliable automatic detection of this phenomenon in an operational setting, e.g., at low altitudes in the strong clutter environment which is typical of the approach and departure corridors of major airports, has not been demonstrated. Some of the difficulties in making this measurement with JDOP type sensors will be discussed in the next section.

3. Vertical Wind Fields

Estimation of the low level vertical wind fields (velocity and shear) presents a challenging problem for radar meteorology since this component cannot be directly measured in general**. A common approach is to estimate this from divergence (or convergence) of measured radial wind fields[52]. Low level horizontal wind fields are hard to measure with the requisite accuracy due to terrain shielding, clutter, and sidelobe effects. The analysis of

*the SNR is proportional to C_n^2 .

**the use of vertically pointed Doppler radars would be far too costly given the size of the required coverage volume.

upper level wind fields is complicated by radar coverage constraints, as well as uncertainties in the air vertical velocity estimation, due to variations in the raindrop terminal fall speed*. At all levels, the simultaneous use of several Doppler radars will probably be essential to estimate accurately the vertical wind fields^[52]. It seems likely that a considerable amount of basic meteorological research may be necessary before weather radar estimated vertical wind fields can be usefully deployed in operational ATC systems.

4. Hail

Hail detection by means of reflectivity levels occasionally fails due to difficulties in distinguishing between hail and high level rain reflectivity. It now appears that the storm structure (e.g., speed and size of the updraft region and divergence of flow at the top of the updraft region) are also needed to reliably detect hail. The principal technical concerns here are adequacy of the resolution volume at long range in the enroute mode** and fall speed effects.

5. Low Level Wind Shear (LLWS) Detection

The surveillance volume and data update rates required to identify hazardous LLWS conditions is unclear at this time. First, there is a question of whether LLWS will be sensed directly (e.g., via radar measurements on the air volume the aircraft will fly through) or, inferred by determining the local meteorological structure and using that to estimate LLWS regions. Secondly, there is some uncertainty as to the characteristics of meteorological disturbances which could create LLWS. Table 2.5 shows the scales, durations and wind speeds suggested by Fujita, Wilson and McCarthy ^[58]. The frequency of occurrence and hazardousness of microbursts is under investigation at this time***. A major experimental study (the JAWS project ^[81]) will be carried out. Direct measurement of such phenomena would clearly require faster update rate, and longer dwell times than is the case with the en route weather phenomena.

*the observed vertical velocity is the sum of the air velocity and the raindrop terminal fall speed. Since terminal fall speed depends on the rain drop sizes, it may be necessary to infer rain drop sizes from reflectivity.

**the use of vertically pointed Doppler radars would be far too costly given the size of the required coverage volume.

*** Fujita ^[48] has argued that microbursts have been the principal cause of most LLWS CC accidents in recent years; however, microbursts are not identified as a significant weather feature in the NEXRAD system documents ^[60]. It should also be noted that aircraft response characteristics may be important in identifying hazardous LLWS ^[49].

TABLE 2.5

CHARACTERISTICS OF LOW LEVEL WIND-SHEAR DISTURBANCES ASSOCIATED
WITH CONVECTIVE STORMS (FROM REFERENCE 58)

<u>Wind-shear Disturbances</u>	<u>Horizontal Dimensions</u>		<u>Lifetime</u>	<u>Maximum Windspeed</u>
	<u>(in km)</u>	<u>(scale)</u>		
Gust front	10 to 100 km	Mesoscale	1 to 10 hours	40 m/s
Downburst	4 to 10 km	Mesoscale	10 to 60 min	50 m/s
Microburst	1 to 4 km	Mesoscale	2 to 20 min	60 m/s

C. Assessment of JDOP NEXRAD Radar Design

In order to assess the significance of the FAA requirements for coverage, measurement accuracy, and update rates, it is instructive to see how these requirements would constrain the design and performance of a typical Doppler radar sensor.

The JDOP Final Report^[23] includes a specification of the basic parameters for a Doppler weather surveillance radar suitable for detection and tracking of mesoscale features of severe storms, and for early detection of tornadic storm signatures at long ranges, up to perhaps 250 km. Some of this information is repeated in Tables 2.6 and 2.7. The proposed design is for an S-Band coherent Doppler radar with a 1° pencil beam and a batched, selectable PRF capability similar to the research radar now employed at NSSL. This configuration will be referred to as the JDOP radar. It will be shown in this section that a network of properly sited JDOP radars should be capable of meeting the bulk of the FAA weather surveillance requirements in the en route airspace. For the purposes of this analysis, the NEXRAD network is assumed to consist of the preliminary NEXRAD locations listed in reference 6.

It is natural to consider the effectiveness of using the same network of radars to provide the required weather products for the 76 priority FAA terminal/airport airspaces in addition to covering the en route airspace. Because low altitude surveillance and detection would be required, proper siting and effective clutter cancellation become dominant concerns, whereas for the en route airspace they are less critical. These issues are also addressed, and it will be shown that there are some fundamental difficulties in attempting to do both jobs using the same network of radars.

1. Accuracy and Reliability of Measurements

The accuracy of the meteorological measurements made with pulse Doppler radar is a function not only of radar parameters such as transmitted power, PRF, dwell time, and receiver sensitivity, but also of the feature being measured. In using the JDOP radar to make estimates of reflectivity, I ; radial velocity, v ; and spectrum width, σ_v ; from each radar resolution cell, the parameters under control of the observer are Pulse Repetition Time (PRT), T_s , and antenna rotation rate, ω .

Rotation rate limits the maximum dwell time, if it is assumed, as is customary^[17], that the maximum azimuthal and elevation dimensions of the observation volume are to correspond to the radar beamwidth. Decreasing the PRT for a given Ω will increase the number of samples taken in the resolution volume. The amount by which the final estimate variances of I , v , and σ_v are reduced by averaging these samples depends on the signal-to-noise ratio and on the degree of statistical independence which exists between samples. Statistical independence is determined by the decorrelation time of the underlying physical process being observed.

TABLE 2.6

ILLUSTRATIVE DOPPLER RADAR CHARACTERISTICS

SOURCE: JDOP FINAL REPORT, REFERENCE 23

Antenna

Shape	Parabolic
Diameter	7.32 m (24 ft)
Half Power Beamwidth	1°
Gain	45 dB
First Side Lobe Level	-25 dB max (with radome)
Polarization	Linear-horizontal
Antenna Scan Rate	0.5 to 3 rpm (both planes)
RHI	Yes
PPI	Yes
Manual Scan Control	Yes (both planes)

Transmitter

Wavelength	11.1 cm to 10.3 cm
Frequency	2.7 GHz to 2.9 GHz
Peak Power	500 kW min
Pulse Width	1 μ s
Pulse Repetition Time*	Selectable equally spaced or batch discrete values of 835 μ s, 1024 μ s, 1167 μ s
Duty Cycle	1.2×10^{-3} max

Receiver

System Noise Figure (including radome and waveguide losses)	4 dB
Transfer Function-Doppler	Linear
Transfer Function-Intensity	Logarithmic
Dynamic Range	80 dB min
Doppler AGC	By range gate

TABLE 2.7

ILLUSTRATIVE SYSTEM AND SIGNAL PROCESSING CHARACTERISTICS
(BATCH PROCESSING)

SOURCE: JDOP FINAL REPORT, REFERENCE 23

Pulse Repetition Time for velocity	835 μs	1024 μs	1167 μs
Unambiguous Velocity	31.5 ms^{-1}	25.6 ms^{-1}	22.5 ms^{-1}
Unambiguous Range	125 km	154 km	175 km
Intensity Surveillance Range	500 km	460 km	525 km
Velocity Range Cell Spacing	122 m	150 m	170 m
*Intensity Range Cell Spacing	488 m	450 m	510 m
No. of Intensity Range Cells	1024	1024	1024
No. of Velocity Range Cells	1024	1024	1024
Range Sampling	122 m	112.5 m	127.5 m

Reflectivity

No. of Range Samples Averaged	4
Output Resolution (8 bits)	<.4 dB
No. of Time Samples	Selectable 4 to 32

Velocity

No. of Samples Averaged	Selectable 16 to 256
Output Resolution (8 bits)	<.25 ms^{-1}
Estimated Standard Deviation	
Intensity	1 dB to 1.7 dB
Velocity	0.5 ms^{-1} to 0.9 ms^{-1}
Width	0.6 ms^{-1} to 1 ms^{-1}

*In equally spaced pulse mode, the intensity and velocity range resolution is the same.

For a weather process with an ideal Gaussian spectrum, the decorrelation time is a function of the spectrum width, σ_v , and the radar wavelength, λ . The normalized autocorrelation function magnitude for such a process may be written: [19]

$$\rho(\tau) = \exp[-8(\pi\tau\sigma_v/\lambda)^2] \quad (2-1)$$

The decorrelation time, τ_d , is defined to be the time at which $\rho(\tau_d) < e^{-1}$. For the autocorrelation function of (2-1):

$$\tau_d > \frac{\lambda}{2.8\pi\sigma_v}$$

At S-band, we find for a typical range of spectrum widths:

σ_v	τ_d
1 m/s	12 ms
4 m/s	3 ms
10 m/s	1 ms

A rough rule of thumb would be that one independent sample is obtained from the radar pulse volume every 5 ms of dwell time. Of course the number of independent samples required to obtain a specified estimate variance still depends on the single sample signal-to-noise ratio.

Rigorous derivations of the variance formulas for I , v , and σ_v estimates may be found in papers by Zrnic', Doviak, and Sirmans [5,18,19]. Approximate expressions for variance, assuming autocovariance

processing to get v and σ_v , are given in Table 2.8. These expressions have been used to generate the curves in Figure 2.7. Although it is not obvious from the formulas, the variances of v and σ_v increase with σ_v , while for I , variance decreases with σ_v .

Note also that the variance of I is not sensitive to PRT or SNR, but depends only on dwell time and spectrum width. However, the ability to determine very low level signals (e.g., SNR < 0 dB) in an operational situation will be difficult since it requires attaching significance to small changes in I (i.e., fractional dB) from that which arises with front end noise.

Figures 2.8 and 2.9 show the single pulse SNR as a function of range for the radar described in tables 2.5 and 2.6. It was assumed that the system losses (e.g., due to receiver bandwidth and waveguide) were 4 dB and the pulse repetition time 1 ms. We see that high level precipitation (e.g., > 20 dBz) will yield a large SNR out beyond the unambiguous range of the radar provided

TABLE 2.8

EXPRESSIONS FOR VARIANCE OF ESTIMATES OF I, v, σ_v .

For I, a square law receiver is assumed. For v and σ_v , autocovariance processing of equally spaced pulses from a linear receiver is assumed. Approximations are not valid for spectral widths < 1 m/s

N/S = Noise-To-Signal Ratio (power)

λ = Radar wavelength (m)

T_s = PRT

σ_v = Spectrum width (m/s)

M = number of pulses

$$\rho(T_s) = \exp[-8(\pi\sigma_v T_s / \lambda)^2]$$

REFLECTIVITY

$$\text{VAR}[I] \approx 20 \log \left[1 - \sqrt{\frac{2}{M_I}} \right] (\text{dB}), \quad M_I^{-1} = M^{-2} \sum_{k=-K}^K (M - |k|) \rho^2(kT_s) \quad K=M-1$$

VELOCITY

$$\text{VAR}[v] \approx \frac{\lambda^3 [1 - \rho^2(T_s)]}{128 M \pi^{5/2} T_s^3 \rho^2(T_s) \sigma_v} \quad (\text{m/sec})^2 \quad \text{S/N} > 10 \quad (+10\text{dB})$$

$$\approx \frac{\lambda^2}{32 \pi^2 M T_s^2 \rho^2(T_s)} \quad \left(\frac{N}{S} \right)^2 \quad \text{S/N} < 0.1 \quad (-10 \text{ dB})$$

SPECTRUM WIDTH

$$\text{VAR}[\sigma_v] \approx \frac{\lambda^4 \{ [1 - \rho^2(T_s)] + 2[1 - \rho^2(T_s)]^2 N/S + [1 + 2 \rho_s^2(T)] (N/S)^2 \}}{512 M \pi^4 T_s^4 \sigma_v^2 \rho^2(T_s)} \quad (\text{m/sec})^2$$

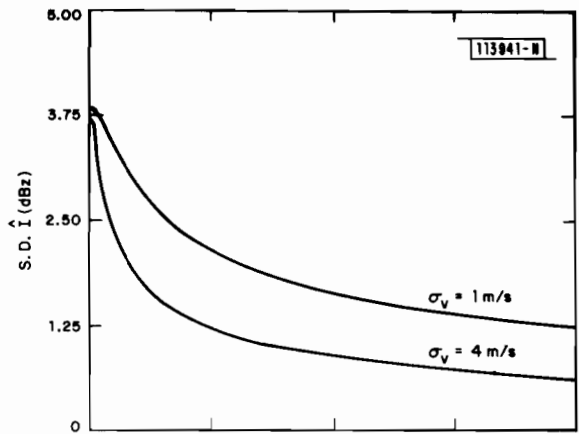

(a)

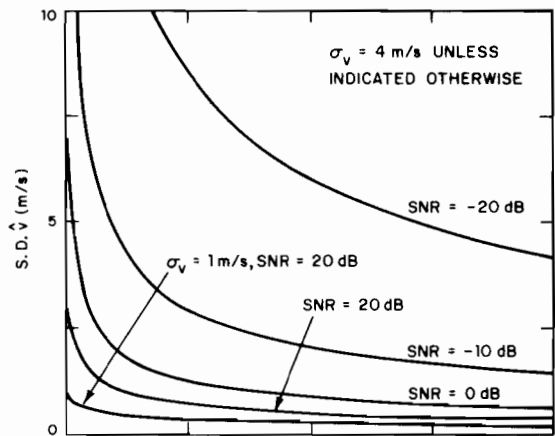

(b)

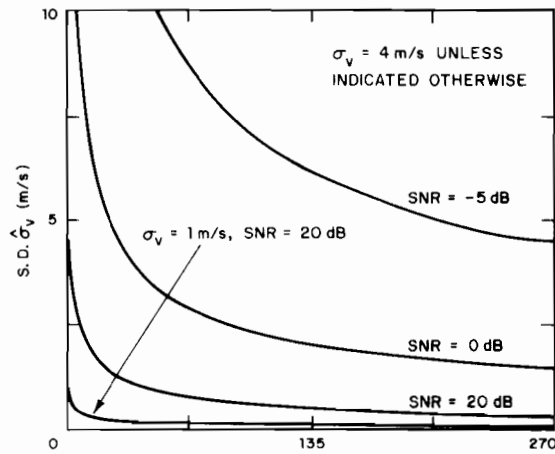

(c)

Fig. 2.7a-c. (a) Standard deviation of reflectivity estimate vs dwell time. (b) Velocity estimate vs dwell time. (c) Spectrum width estimate vs dwell time.

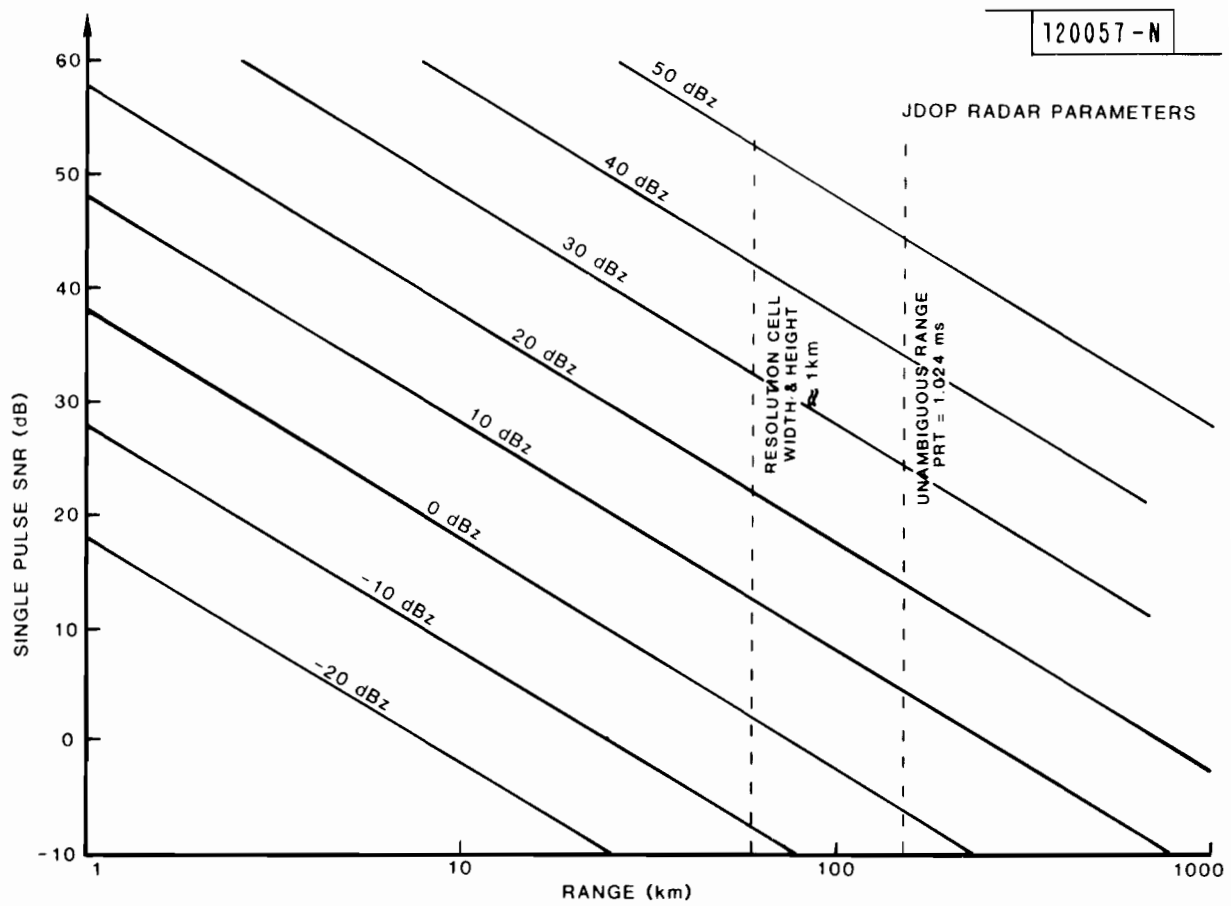

Fig. 2.8. SNR vs range for representative precipitation reflectivities.

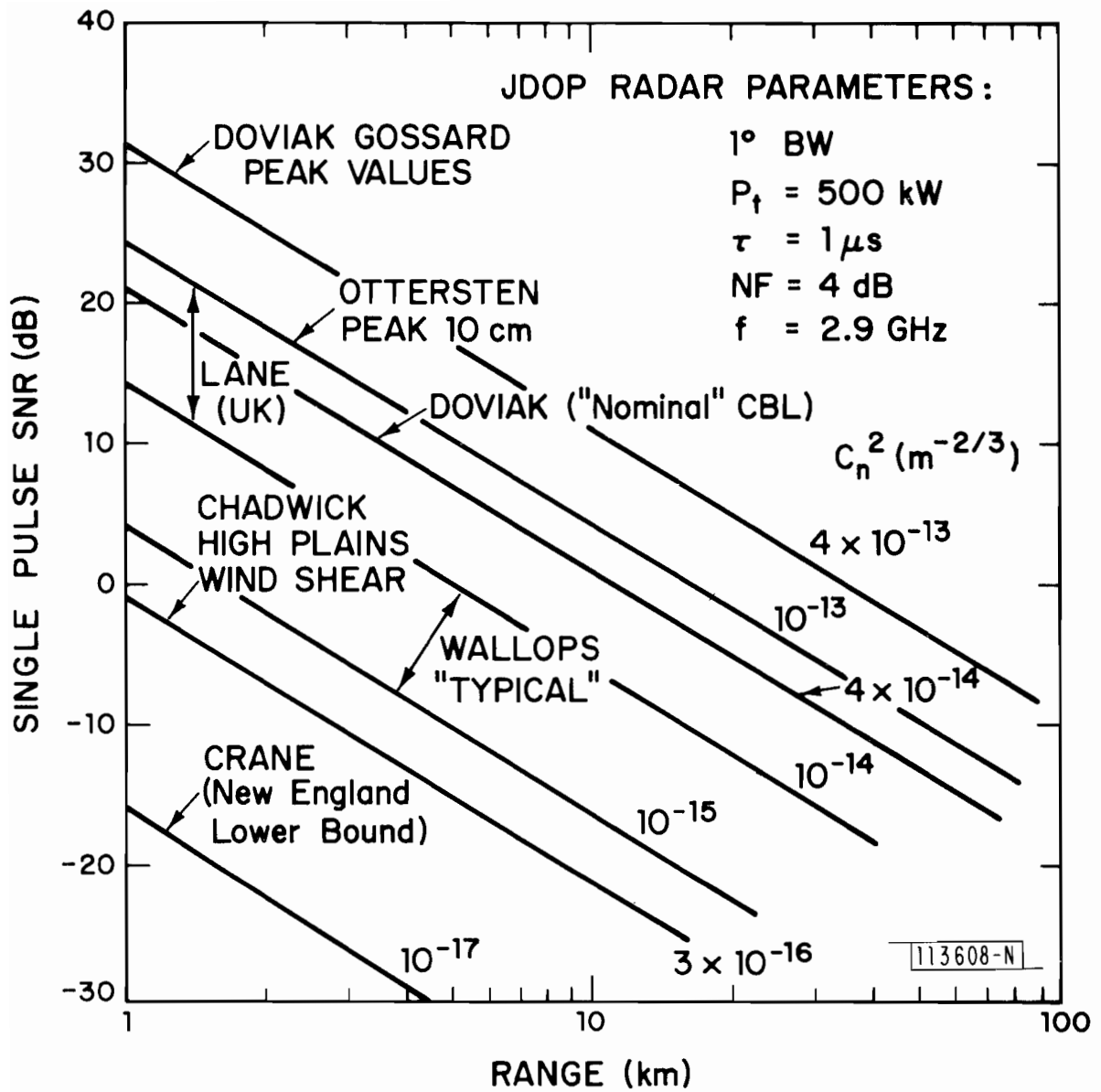

Fig. 2.9. Clear air reflectivity SNR vs range.

that it fills the beam horizontally and vertically. It has been observed, however, that regions of high wind shear and/or turbulence near thunderstorms can occur in regions of much lower reflectivity (e.g., 0 dBz).

Doppler measurements of clear air wind fields and turbulence which rely on refractive index variations are much more difficult to achieve. We see from figure 2.9 that SNR values less than 0 dB must be anticipated at ranges greater than 10 km. Since the ground clutter environment will be particularly severe in the first 10 km, clear air Doppler measurements will often need to be accomplished at SNR levels less than 0 dB; the required number of samples to obtain a given estimate variance will increase as $(N/S)^2$ for both the mean velocity and spectral width estimators.

For a spectral width of 4 m/s (corresponding to moderate to severe turbulence within 60 km of the radar), the spectral width estimator requires approximately 9 times as many samples to achieve the same standard deviation (S.D.) as does the mean velocity estimator. Table 2.9 summarizes the integration times required at several low SNR values.

We conclude from the table and figures 2.7 and 2.9 that obtaining useful Doppler information from clear air will be difficult at best if this is to be accomplished as a part of the normal NEXRAD volume scan (e.g., 7-20 elevation angles scanned within a 5 minute update period corresponding to 1.4 to 4.0 rpm). Achieving useful information within even small sectors on a time division multiplexed basis will be possible only if the C_n^2 and range are such as to yield a SNR > -10 dB.

The high values of C_n^2 which are needed to achieve a SNR as high as -20 dB at useful horizontal ranges are associated with the convective boundary layer. Since this layer is generally less than 1.5 km thick, radar visibility of the region becomes an important issue since the C_n^2 values at greater heights yield SNR levels which are far too low at the ranges of interest.

It is important to realize that these variance formulas are derived by making certain assumptions about the nature of the underlying physical processes being measured - assumptions which are in reality violated. For instance, the observed shapes of weather spectra often deviate significantly from the assumed symmetrical Gaussian shape.

Operation at longer ranges (e.g., greater than 60 km) with a 1° beam width may generate certain bias terms as well as increased estimate variance due to low SNR. At ranges beyond 60 km, the reflectivity cells of thunderstorms will more frequently fail to satisfy the beam filling criteria on which an accurate measurement of reflectivity is based. This causes high altitude cells to appear more benign than would be the case otherwise. Beyond 60 km, the turbulence cannot be isotropic within the radar pulse volume and hence the validity of spectral width as a turbulence indicator becomes even more questionable.

TABLE 2.9
 INTEGRATION TIMES AND ROTATION RATES
 FOR DOPPLER MEASUREMENTS AT LOW SNR

Integration Time (in seconds) and Rotation Rate to
 Achieve 1.5 m/s Standard Deviation In

SNR (dB)	Mean Velocity	Spectrum Width
1		
0	0.04 (4 rpm)	0.2 (0.8 rpm)
2		
-10	2.4 (0.07 rpm)	21 (0.008 rpm)
-20	238 (0.001 rpm)	2100 (0.0001 rpm)

Notes:

1. Based on simulation results due to Zrnic' [18]
2. Based on Table 2-7 formula terms proportional to $(N/S)^2$
3. Spectral width assumed to be 4 m/s in all cases

2. Coverage and Resolution

Figure 2.10 depicts the three different FAA airspaces, and the ideal range/elevation space that would be accessible to a single JDOP sensor. The presence of obstructions and terrain variations is neglected. This is a reasonable assumption when talking about the coverage that could be obtained in the en route airspace by a JDOP radar sited at one of the 56 existing NWS sites. Most of these sites have been advantageously chosen to avoid blockage at low elevation angles.

Note that beyond 96 nmi (178 km), the specified minimum en route altitude coverage (down to 6000 ft.) cannot be provided. At about this same range, a 1° pencil beam radar begins to have problems in meeting the required 3 km volume resolution capability. Also, as mentioned in the previous section, the accuracy of reflectivity and spectrum width estimates becomes much more suspect at longer ranges.

All of these factors suggest that, ideally, the maximum range coverage required of any NEXRAD sensor would be limited to 96 nmi or less for quantitative observations for air traffic control applications.

A second aspect of coverage has to do with the span and spacing of elevation angles used by the sensor. The implied choice of surveillance volume dimensions is significantly constrained by the simultaneous 5 minute update requirements and the stated FAA measurement accuracy requirements. The implications for sensor design and system performance have been examined elsewhere^[3,8,12]. A few brief comments are offered here to illustrate the problems.

It has been suggested that a reasonable upper limit on elevation coverage is 20° [12]. If a JDOP radar is required to scan out the entire volume defined by this limit, this could be done with 20 elevation cuts spaced one beamwidth apart. A full volume update would be possible every 5 minutes if the antenna were scanned at 4 rpm. The resulting high SNR reflectivity estimates would have a S.D. of 1.5 dB and the Doppler estimates would have S.D. of 2 m/s. Although neither of these values meets the present FAA accuracy requirements, the reflectivity accuracy may be acceptable but the v and σ_v accuracies are not*.

Another study assumes that it is necessary to cover elevation angles up to 30° with no decimation^[3], and still meet the 5 minute volume update requirement. The radar designs considered involve multiple 1° elevation beams. Although such systems appear to satisfy the FAA's en route coverage and update requirements, the problems of altitude resolution and measurement accuracy at long ranges remain.

*e.g., a 2 m/s spectral width error at 50 km range corresponds to an error in $\epsilon^{1/3}$ of 3.

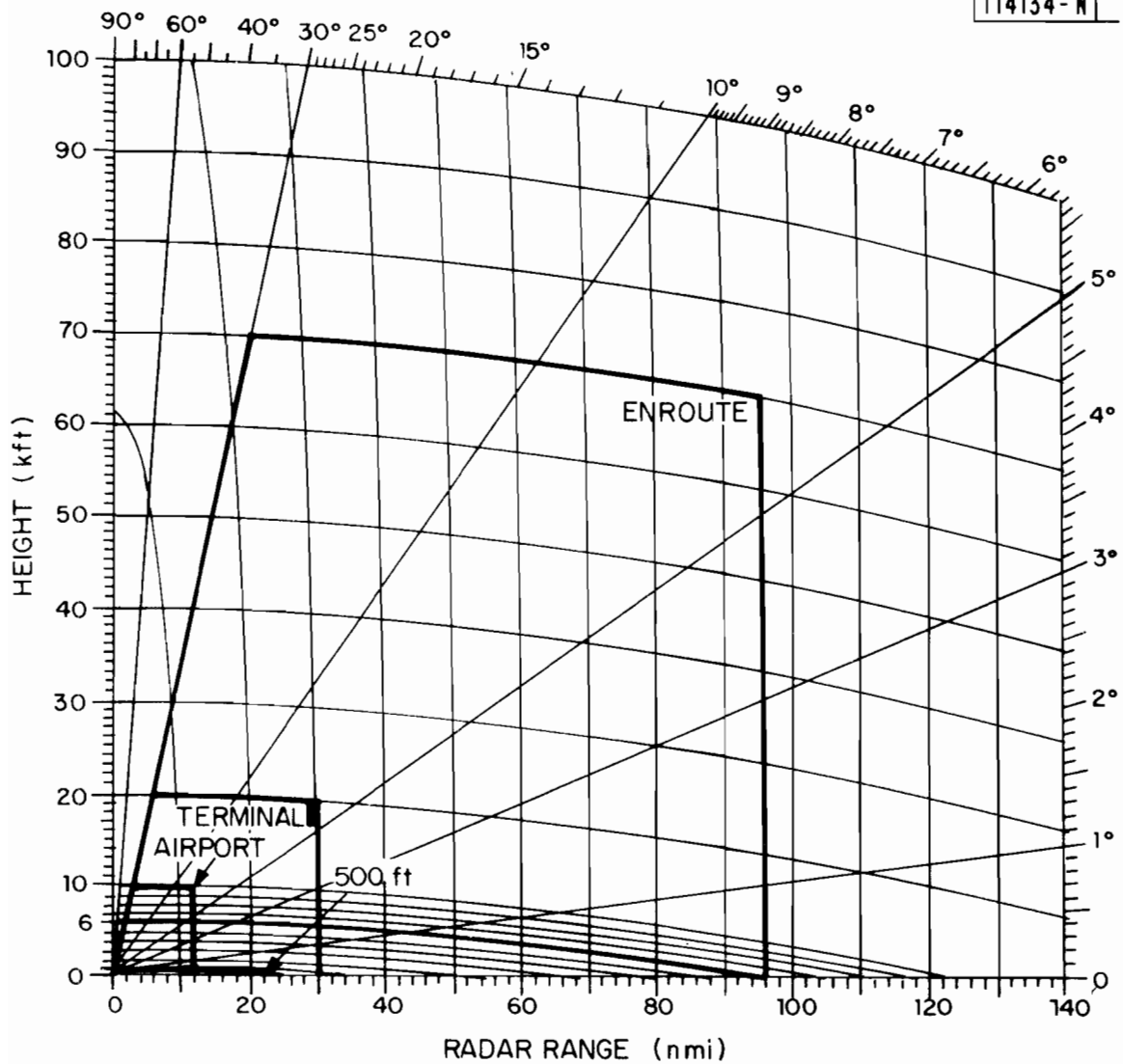

Fig. 2.10. Airport, terminal and en route coverage requirements assuming a single sensor sited at airport.

Regardless of the complexity of the antenna and scan strategies employed, compromised performance will have to be accepted in regions of the en route airspace where NEXRAD radars are spaced more than 96 nmi apart.

If the proposed NEXRAD network^[64] is also used to provide terminal and airport surveillance, there are further implications for coverage and accuracy, as revealed by Figure 2.11. This figure is a graphic presentation of the proximity data compiled in Appendix C. The information in this figure is overly optimistic because it has been assumed for convenience that terrain and man-made constructions in the vicinity of the FAA designated airports will not affect coverage from adjacent NEXRAD sites. The errors in this assumption are explored in the next section.

The upper part of the figure shows the relationships between range to nearest NEXRAD site and (a) minimum altitude that could be covered over the airport; and (b) azimuth and elevation resolution over the airport. In the lower part of the figure, histograms of distance to the nearest proposed NEXRAD have been drawn for (a) the 40 FAA designated airport sites, and (b) an additional 33 FAA designated terminal sites (3 of the terminal sites are outside of the CONUS). The airport histogram is offset by 10.8 nmi; the terminal histogram by 30 nmi. This is so that the altitude and resolution curves above will give the worst case situation at the farthest extremity of the airport or terminal airspace.

The figure shows that even neglecting obstruction problems, the only way to approximate the required terminal or airport resolution and low-altitude coverage requirements everywhere in these airspaces (using a single sensor) is with siting directly at the airports. Twenty-four of the 40 airport sites and 15 of the 33 terminal sites are presently listed as potential NEXRAD sites.

A previous study suggests that, in addition to the compromised en route coverage already mentioned, compromised but reasonable terminal area service could be produced by using an adjacent NEXRAD radar (up to 190 km away) to provide degraded, partial coverage of the airport cone of silence^[12].

However, from Figure 2.11 it is seen that altitude resolution in the airport cones of silence would vary from 1 to 3.4 km, while minimum altitude covered would vary from perhaps 150 m to 2500 m. This granularity of resolution is not adequate to provide quantitative estimates of turbulence and wind shear. Thus the cone of silence coverage for many airports will be limited to reflectivity only, estimated in some cases with partially filled beams.

3. Siting: Obstructions and Diffraction

Whether or not the above degradation in coverage is acceptable, the analysis upon which it is based defers some important practical problems which must be solved if NEXRAD is to provide weather surveillance acceptable to the FAA. The first problem has to do with terrain and obstruction effects in the vicinity of the airports on the FAA list.

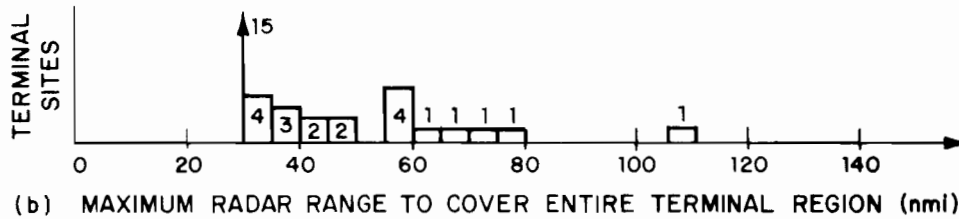
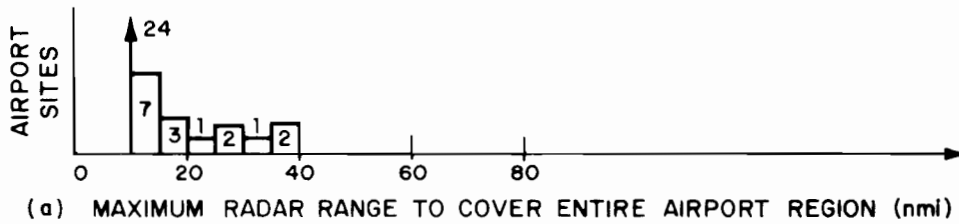
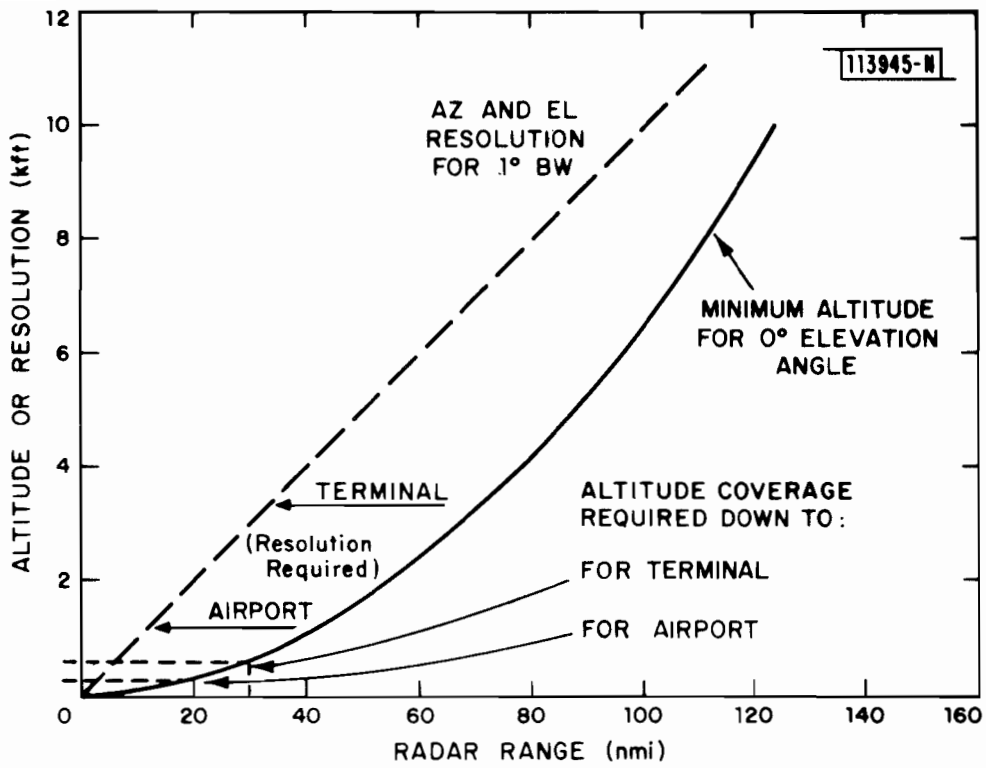

Fig. 2.11. Coverage statistics for revised NEXRAD siting.

As an example of this, consider Boston's Logan International Airport. According to Appendix B, the closest proposed NEXRAD site is located at Pease AFB, N.H., 43 nmi away. Boston would thus be a candidate for a special use NEXRAD site located at the airport. Even with a special-use radar directly on the airport, airport/terminal coverage at low altitudes cannot be obtained down to, say, 250m altitude in all directions, because of hills and buildings.

Figure 2.12 is taken from a siting study of Logan Airport, performed for the DABS Program^[7]. The horizon angle was measured with a transit positioned at the existing ASR-7 site on the airport. As seen in the figure, there are many tall buildings surrounding the airport. The Boston skyline (between 2 and 3 nmi away) blocks coverage over approximately a 50° sector to the west, at elevation angles ranging from 0.8 to 2.6 degrees. Blockage produces horizon angles up to 0.5 degrees in several other sectors as well. Note that Figure 2.12 shows the optical horizon. The true microwave horizon profile is even worse, since the lower edge of the main lobe of the antenna pattern must clear these obstacles to avoid diffraction problems. This horizon profile is among the worst among the 76 FAA airports, but others including Denver, Salt Lake City and Los Angeles pose comparable siting problems.

Figure 2.13 is a reproduction of a portion of the calibrated 360° horizon measurements performed by the FAA at Salt Lake City Airport in connection with the DABS measurement program. The measurement site was approximately 1 nmi north of the airport. The figure shows the Wasatch Mountain Range which runs north/south, 10 to 12 miles east of the airport. The maximum horizon angle produced by these mountains is 5°, and the horizon angle is 3° or more for the azimuth sector from 20° through 155° true north.

Inspection of a 4/3 earth chart such as the one shown in Figure 2.10 reveals how rapidly the low-altitude coverage deteriorates at medium to long ranges, as the minimum elevation angle increases. At 141 nmi, blockage of as little as 1° prevents the radar from seeing below 28,000 ft. At 96 nmi, the minimum altitude is still 17,000 ft. Thus, relocation of NEXRAD radars to nearby airports in an attempt to meet FAA terminal requirements will have significant impact on the ability of NEXRAD radars to cover each other's cones of silence in the en route airspace.

Field experience with the L-band ATC Radar Beacon System (ATCRBS) and C-band Microwave Landing System (MLS) has shown that diffraction by obstacles near the horizon can create sizable angle measurement errors, as well as loss in received signal strength^[75-80]. Figure 2.14 shows how ATCRBS azimuth errors correlated with obstacle locations in tests at Logan Airport. The diffraction errors are quite predictable* given the shadowing geometry (figures 2.15 and 2.16). Based on the ATCRBS/MLS experience, it seems likely that diffraction effects will be of the greatest concern when attempting to make high quality estimates at long range (e.g., furnishing tactical terminal/airport data from an enroute site).

*The MLS propagation model^[77], currently in use at FAATC for MLS studies, could easily be modified to predict shadowing effects on weather radars.

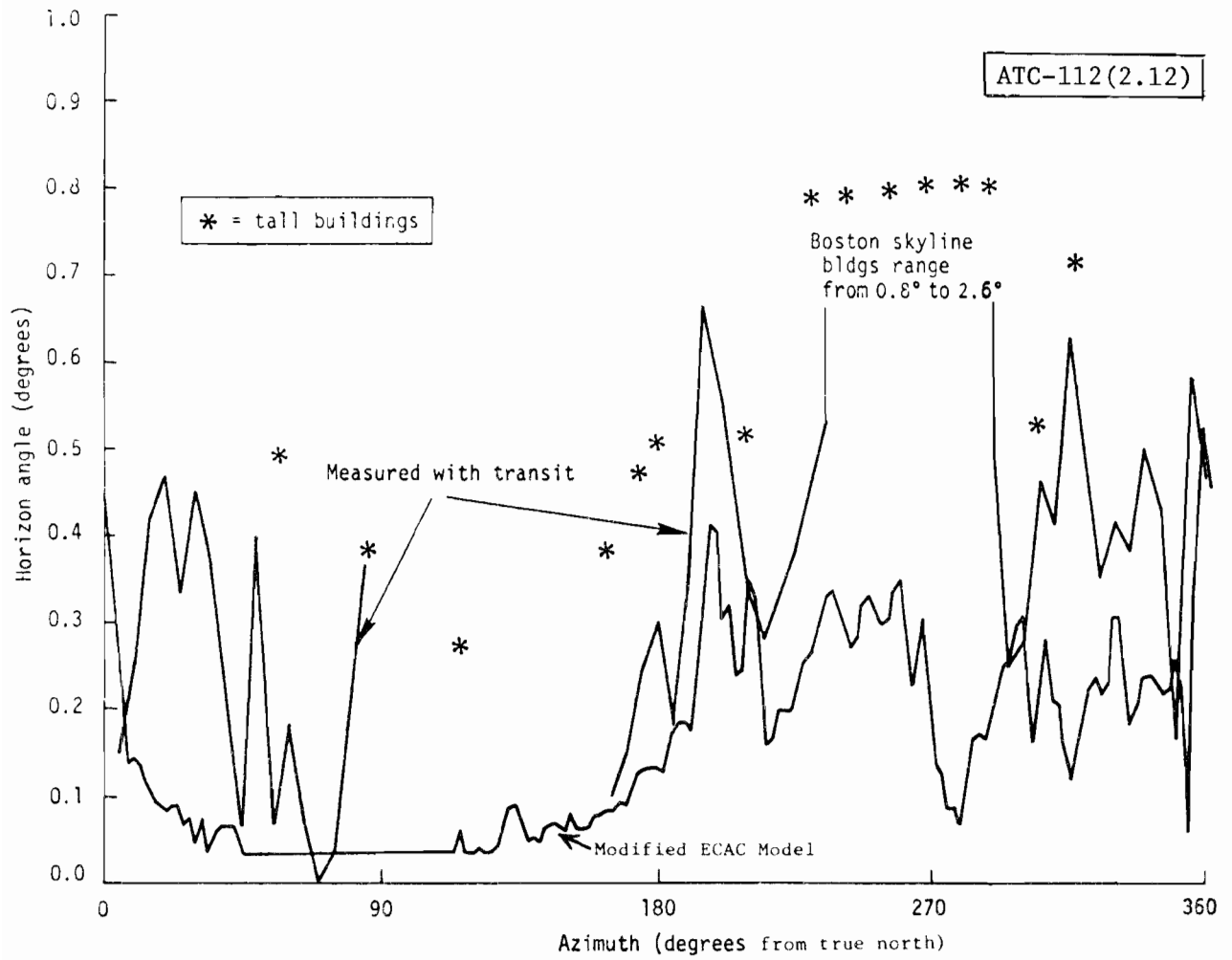

Fig. 2.12. Horizon angle from ECAC model with terrain raised 50 feet compared to optical measurements.

114127-R

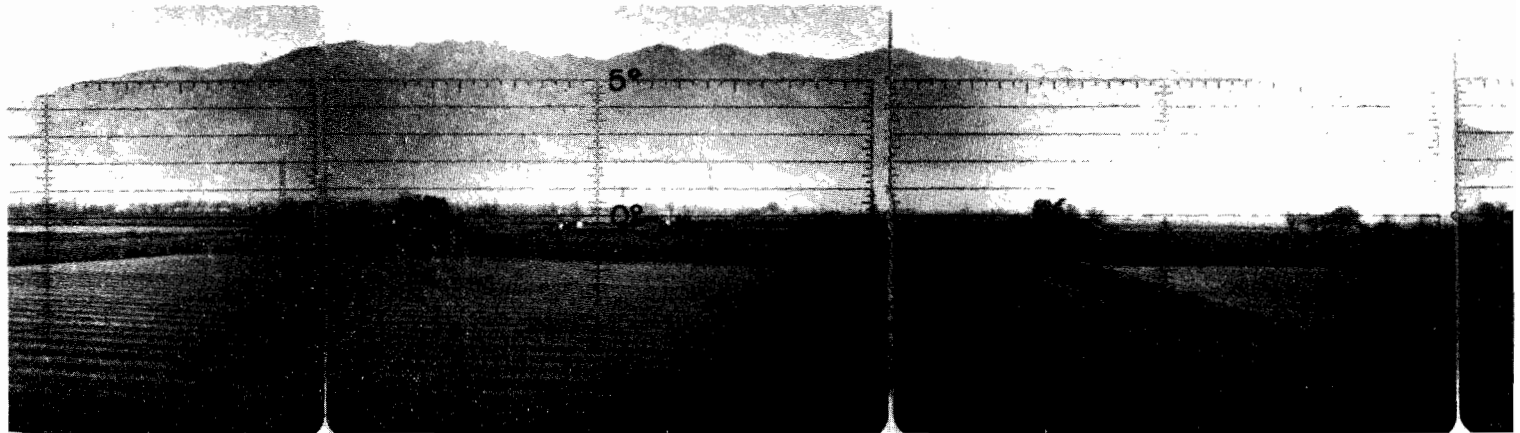

Fig. 2.13. View to east from site about 1 nmi north of Salt Lake City Airport, Utah.

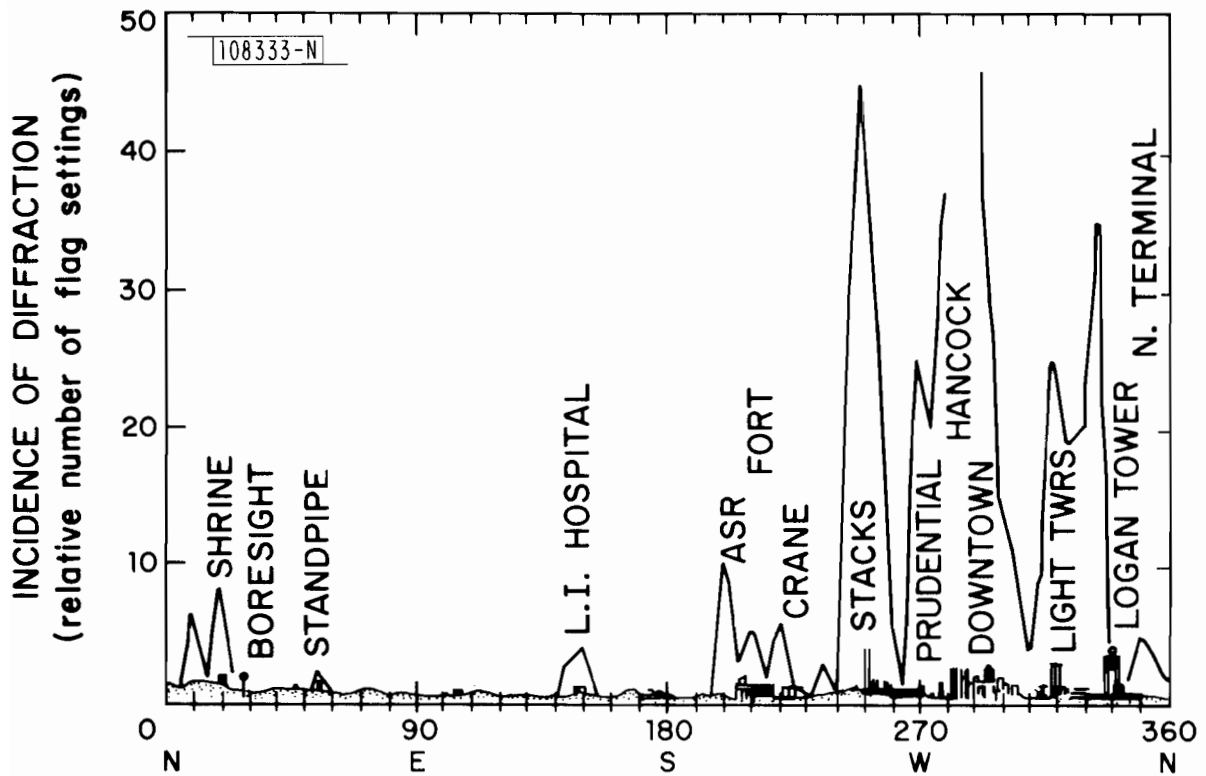
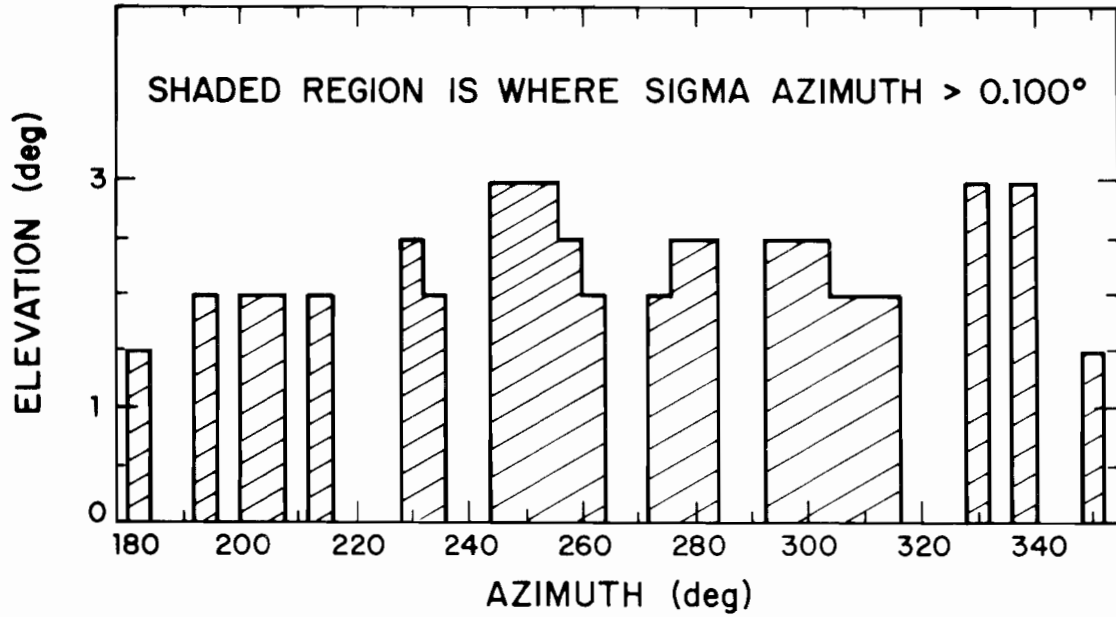

Fig. 2.14. Incidence of monopulse diffraction errors at Logan Airport.

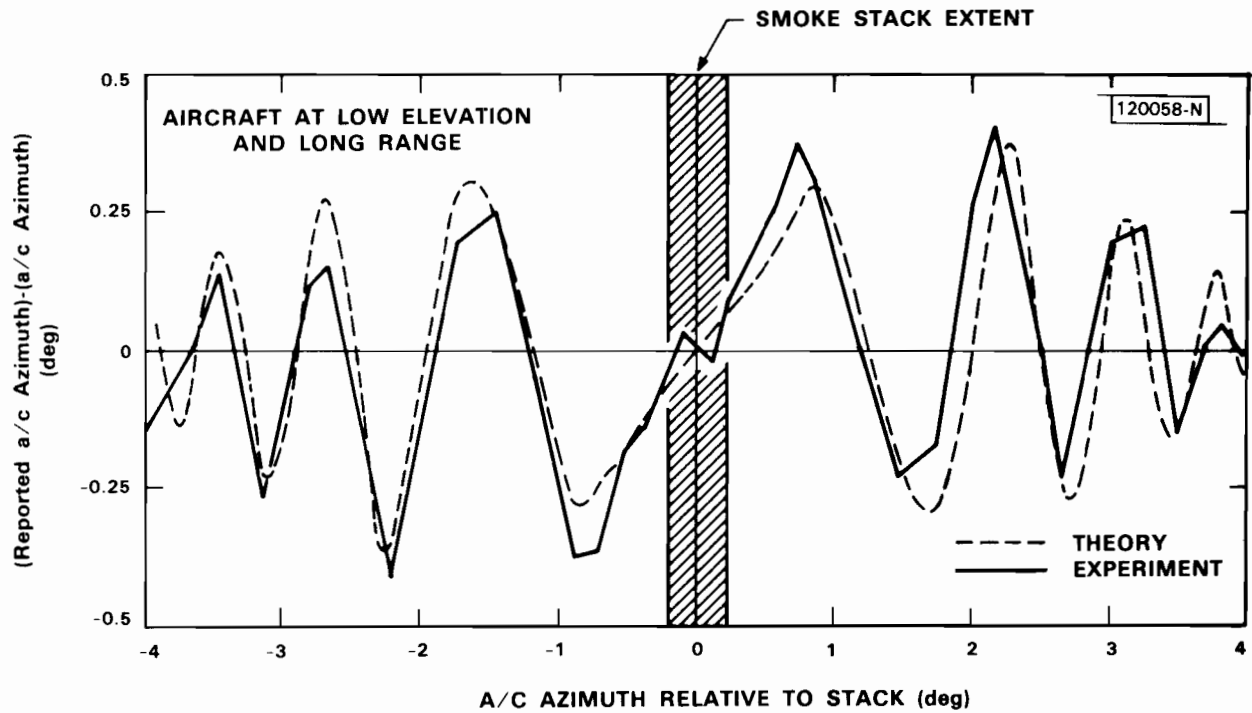

Fig. 2.15. Monopulse azimuth error caused by diffraction from Hanscom smoke stack with aircraft at boresight of DABSEF L-band antenna.

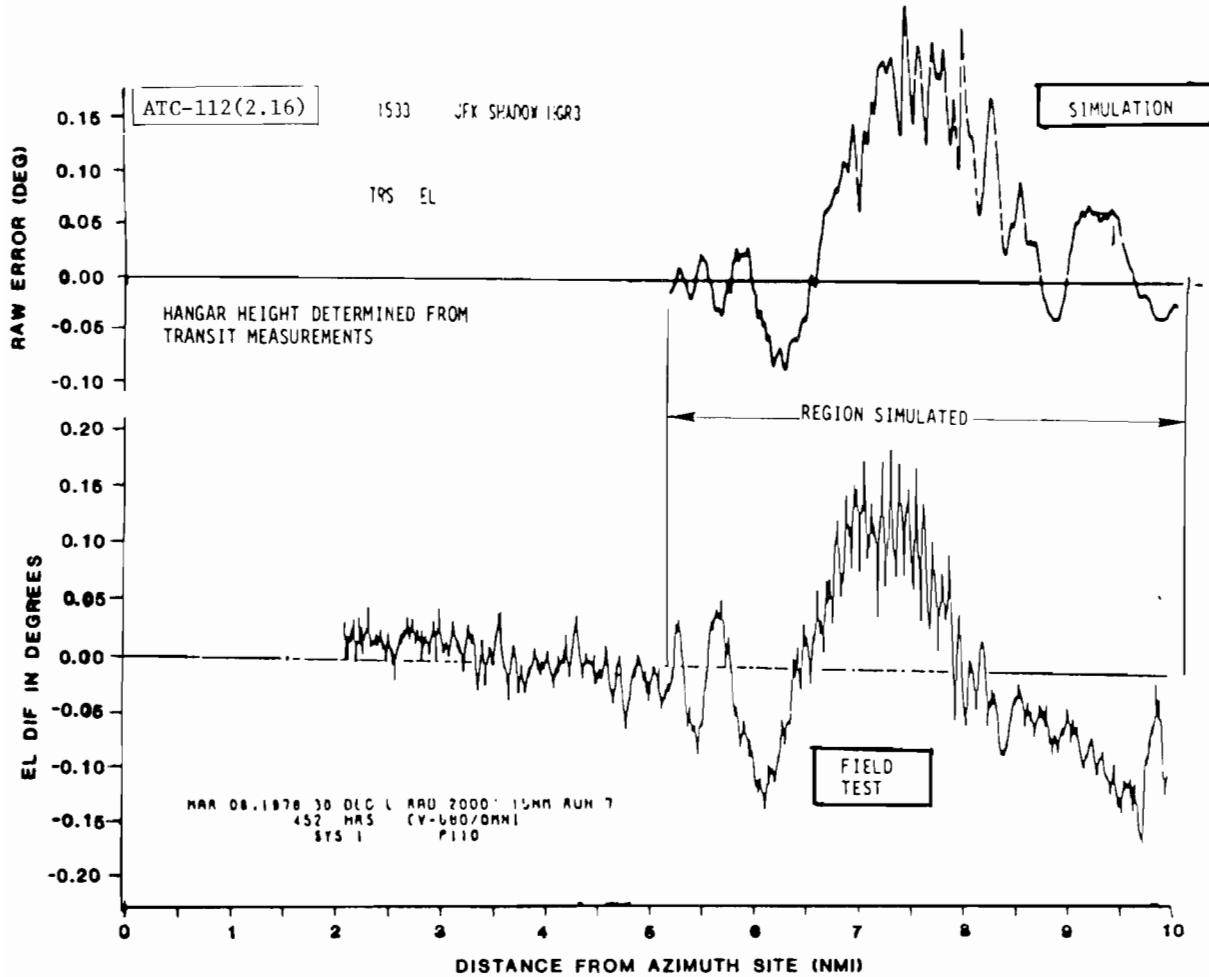

Fig. 2.16. MLS C-band elevation errors due to diffraction from top of hangar at J.F. Kennedy Airport.

The bulk of the radar sensor parameters identified in table 2.6 will have virtually no impact on the diffraction effects. Rather, it is the particular radar site characteristics in relation to the desired coverage area which dominate the performance. Thus, diffraction effects will probably have little or no impact on the NEXRAD radar design, but will influence the site selection and possibly the number of radars which must be purchased.

4. Siting: Fixed and Moving Ground Clutter

A third important problem affecting siting and radar design has to do with ground clutter. NEXRAD sensors sited more than 1-2 miles off of major airports, and perhaps less than 10 miles away might in principle be capable of providing coverage of the airport/terminal airspaces. The degradation in resolution would be significant, but the most serious problem would be the large dynamic range required (90 dB at IF) in order to avoid receiver saturation due to the ground clutter power returned from metropolitan areas which fall within the radius of the terminal/airport airspaces at major airports.

The DABS/MTD experience at Clementon, NJ is illustrative of the severity of clutter problems that can be encountered when attempting to provide low-altitude coverage of the airspace around a major urban airport from a standoff site. The Clementon site is approximately 12 nmi ESE of Philadelphia International Airport. The elevation at the airport is 10-15 ft MSL.

The Clementon radar (an ASR-8) is on a tower at the top of a hill, placing the antenna approximately 230 ft MSL, with a clear view toward the airport and the Philadelphia/Camden metroplex, as shown in Figure 2.17.

The Clementon site was specifically chosen after it was found that the airport site suffered from severe problems with diffraction from nearby buildings and bridges, which were causing azimuth errors in beacon tracking. Siting at Clementon effectively eliminated these problems.

When a simple two-level weather thresholding algorithm was added to the MTD system processing, it was discovered that there were a large number of regions around the airport where the ground clutter-to-noise power was in excess of 74 dB, resulting in saturation of the video channels without IF STC. Additionally, it was discovered that the radar was detecting ground vehicular traffic on many road segments in the area - a type of interference which cannot be removed with DC ground clutter filtering. In the end, it was necessary to create a clutter map of the region, which delineated areas where low altitude weather surveillance was denied. This map is shown in Figure 2.18.

174136-R

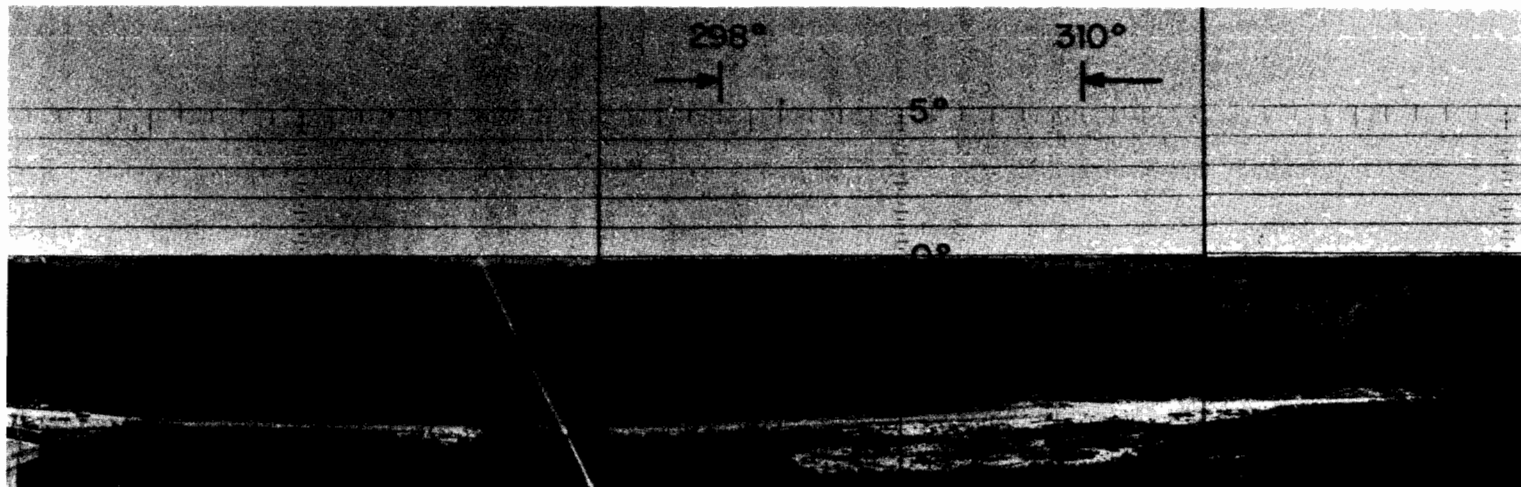

Fig. 2.17. View toward Philadelphia from Clementon DABS ASR-8 site.

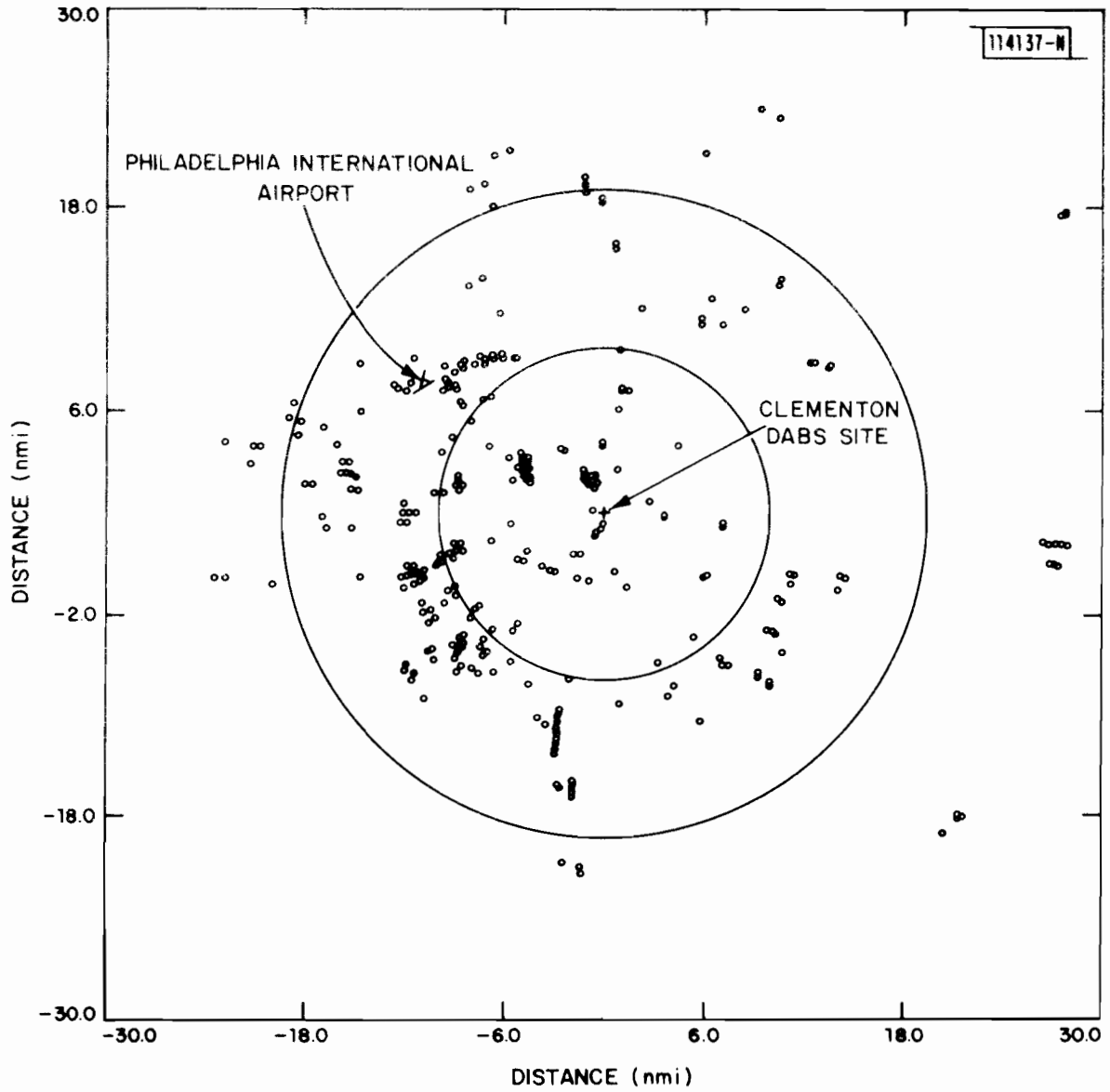

Fig. 2.18. Cell suppression map of Philadelphia area as seen by an ASR-8 at the Clementon, N.J. DABS site.

Figure 2.19 shows the behavior of the single pulse clutter-to-noise ratio, C/N_0 , as a function of range. A system front end noise level of -112 dBm is assumed, and the clutter is assumed to have a differential scattering cross section, σ_0 , of -10 dB. This is typical of the worst case situation which occurs when looking at urban ground clutter at low grazing angles. The single pulse weather-to-noise ratio, $weather/N_0$, is also shown for relatively weak (+10 dBZ) and very strong (+70 dBZ) weather echoes.

It can be seen that to operate at ranges less than 10 Km, the system will require a large dynamic range, in excess of 90 dB, when working at low elevation angles, to avoid saturation by ground clutter returns. Note that in a constant PRF system, similar to that suggested in the JDOP report*, ground clutter in the first 10 Km will obscure even very strong weather echoes from the first 10 Km of the second, third, and fourth trip intervals, at the Doppler pulse repetition interval.

NEXRAD sensors will clearly have to employ various clutter mitigation techniques to obtain the required amounts of automatic ground clutter rejection at low elevation angles. If geographically-mapped censoring is the only technique used to mitigate against ground clutter then some otherwise reasonable sites will operate with unnecessarily large black holes in surveillance coverage. Some form of digital clutter filtering must also be implemented, in conjunction with a clutter map. The map will be elevation angle dependent and weather level dependent, making manual intervention difficult even for trained radar meteorologists. Automatic clutter rejection is necessary.

5. Data Acquisition Strategy

The import of the preceding sections is that, attractive though it may be to contemplate using NEXRAD sensors with the planned locations and volumetric scanning mode to meet all terminal/airport needs, there are some compelling reasons why NEXRAD should not be expected to provide this service.

Table 2.10 summarizes various distinctions that can be made between en route and terminal weather surveillance systems. Some have been mentioned previously; others emerge when one considers the possibility of using a system specifically designed to meet the unique airport airspace requirements. For instance, assuming best siting for all volumes, surveillance ranges in en route space are up to 5 times the maximum terminal range, and 15 times the maximum airport range. This implies factors of 14 and 23.5 dB increase in sensitivity to obtain the same detection probabilities, neglecting problems with beam filling and undesirable volume averaging effects which occur at long range.

*Section A of chapter III describes this system in some detail.

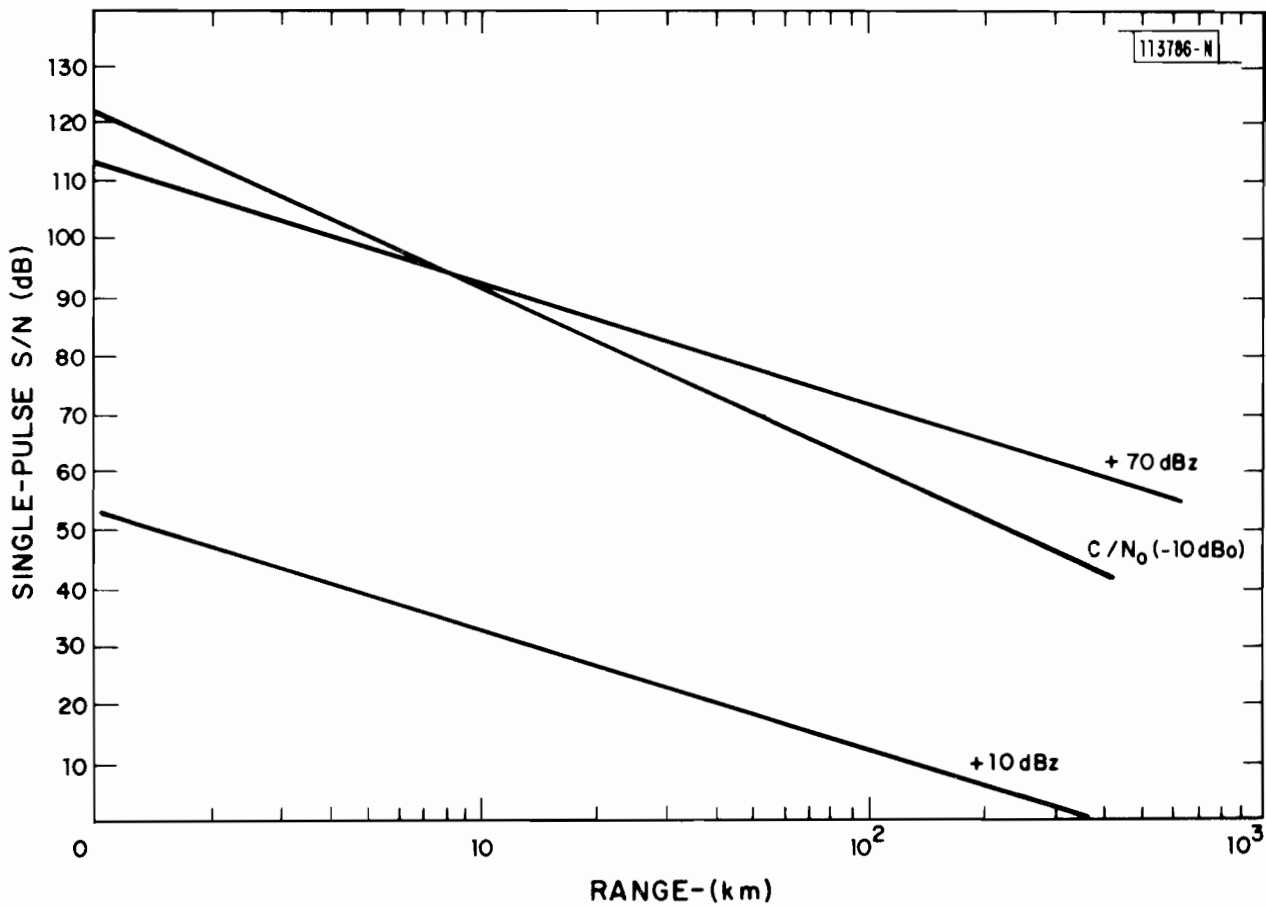

Fig. 2.19. Ideal behavior of C/N_0 as function of range.

TABLE 2.10
TECHNOLOGICAL AND DETECTION ISSUES THAT DISTINGUISH
EN ROUTE AND TERMINAL AREA WX SURVEILLANCE PROBLEMS FROM EACH OTHER

PARAMETER	EN ROUTE	TERMINAL	IMPLICATIONS
MAXIMUM RANGE	96-141 nmi	30 nmi	EN ROUTE: HIGHER POWER, NARROWER BEAMWIDTH (LARGER DISH)
RANGE ALIASING	SIGNIFICANT PROBLEM FOR BOTH TRIPS	ONLY A PROBLEM FOR CLEAR AIR LLWS DETECTION	EN ROUTE: STRATEGIES FOR RANGE DEALIASING REQUIRED TERMINAL: 1ST TRIP PROCESSING ONLY
CLUTTER PROBLEMS	1ST TRIP RETURNS AT LOW ELEVATIONS FOLD INTO ALL TRIPS	1st TRIP RETURNS AT LOWER ELEVATIONS. SIDE-LOBE RETURNS AT HIGHER ELEVATIONS.	EN ROUTE: PRF DIVERSITY AND CLUTTER MAP, DIGITAL FILTERS TERMINAL: LOWER SIDE-LOBES, CLUTTER FILTERS AND MAPS, PERHAPS CLUTTER FENCE
PRF DIVERSITY	REQUIRED	MAY BE REQUIRED	EN ROUTE: CLUTTER REMOVAL MORE DIFFICULT
PRECIPITATION FEATURES	DETECTION AND TRACKING REQUIRED	DETECTION AND TRACKING REQUIRED	RELATIVELY STRAIGHTFORWARD
TURBULENCE AND SHEAR FEATURES	DETECTION IN PRESENCE OF PRECIPITATION HIGHLY DESIRABLE	DETECTION AND TRACKING ESSENTIAL IN PRECIPITATION AND CLEAR AIR	EN ROUTE: DETECTION AT LONG RANGES IS DUBIOUS DUE TO POOR SPATIAL RESOLUTION AND SNR TERMINAL: DETECTION AND TRACKING IN PRECIPITATION FEASIBLE (WITH GOOD ENOUGH RESOLUTION AND LONG ENOUGH DWELL TIMES). CLEAR AIR CAPABILITY UNCLEAR
UPDATE RATE	5 MIN, DECIMATED VOLUME SURVEILLANCE OR TRACKING	5 MIN SURVEILLANCE 30 SEC TRACKING SPECIAL FEATURES	EN ROUTE: NEXRAD STRAWMAN MAY BE ADEQUATE TERMINAL: NEXRAD STRAWMAN PROBABLY NOT ACCEPTABLE

The data acquisition strategy (i.e., choice of pulse transmission times) for terminal/airport airspaces differs significantly from that for the enroute airspace. The range of system PRF values that can be used at S-band to produce quantitative doppler products is perhaps 950 to 1300 Hz. At 2800 MHz (mid S-band) the following table represents the range-velocity ambiguity situation:

Doppler PRF (Hz)	PRT (μ s)	Ra (km)	v_a (m/sec)
950	1053	158	25.5
1300	769	115	34.8

The upper limit is necessary to avoid coherency and (less serious) velocity aliasing problems^[23]. The lower limit is necessary to avoid excessive range aliasing problems at the lower elevation angles.

For any useful choice of PRF, the terminal and airport airspaces will lie well within the first range ambiguity, if the sensor providing coverage is located within a reasonable distance of the airport. The significance of this fact for system architecture is that the transmitter/receiver can be designed with a random-start coho, (phase diversity) as has been done in the FAA/Lincoln Laboratory instrumentation radar at FAATC and with the MIT Meteorology Department radar. This design, which is described in chapter III and ref. [57], has the property that coherent energy from second and higher trip returns (from both ground clutter and distant storms) which would normally overlay and contaminate the first trip weather echoes of interest is whitened (spread out uniformly in frequency) so as to minimize errors in the Doppler estimates. More importantly, a single (variable) PRF is used to obtain both intensity and Doppler measurements. This in turn permits implementation of a more simplified, effective digital clutter canceller.

This is in contrast to the en route surveillance situation. Preliminary siting studies^[6,12] show that most en route sensors will be required to provide coverage out to 178 km (96 nmi), and some will be required to operate out to 260 km (140 nmi) in order to cover each other's cones of silence. The en route sensors will therefore require at least a dual PRT (a long one for reflectivity, and a short one for Doppler), and special processing to detect multiple trip contamination as well as resolve the range ambiguity of the Doppler estimates. In fact, to be acceptable to the FAA, these sensors will require an algorithm which is capable of automatically varying the Doppler PRT and scan rate in real time in order to minimize obscuration effects on hazardous features of interest.

*e.g., due to reflectivity changes with moisture and snow as well as the "anomalous" propagation ducting (often caused by the humidity inversions which arise with summer rain).

A more satisfactory solution from an engineering point of view would be a dual frequency system, operated with two constant PRT's, one long and one short. Unfortunately, cost and frequency allocation constraints may rule it out. The JDOP batch measurement mode has been put forward as a practical single-frequency compromise, but it can be expected to have some significant problems in an operational NEXRAD setting.

When the antenna is rotated at speeds above 1 RPM to provide volume coverage, batch block-lengths will be relatively short (8 or possibly 16 pulses per block). It will be very difficult to achieve the required amount of ground clutter suppression using standard digital filters against so few contiguous pulses. With this scan mode, the ground clutter suppression problem does not appear to have a satisfactory solution at low elevation angles.

The batch system utilizes the low PRF log-intensity channel to range de-alias Doppler products obtained at the high PRF. This form of processing does not provide Doppler products at all ranges out to the ambiguous range corresponding to the Doppler PRF - it leaves holes in the coverage wherever the weather echo does not have a high SNR, and, whenever multiple trip overlays occur. With favorable storm system geometries and low rate scanning, batching can provide Doppler products out to 450 Km, but only for high SNR regions of storms.

Existing experimental radars, e.g. JDOP, have been successfully operated manually to obtain placement of limited storm areas in the clear. Impressive demonstrations of early tornado warning capability have been given by highly trained individuals viewing the raw radar data (I, v, and σ_v fields), and varying the PRF and scan pattern as required. However, in a practical network of en route sensors, this process must be automated.

The automatic adjustment of PRT, scan rate, and sample averaging schemes to obtain good data throughout the entire coverage volume requires a sophisticated real-time interaction between detection and tracking software, and the radar controller hardware. The degree to which this can be achieved in the presence of widespread storm systems (e.g., such as occur in New England) or, when a frontal system coincides with a radar radial have not been demonstrated. The possibility that other design alternatives exist which are more suitable for automation is explored in section III.

6. Summary of Conflicts Between Terminal/Airport Surveillance and NEXRAD Network Usage

One of the principal features of the NEXRAD concept is the use of a network of radars to simultaneously meet the various users requirements. The conflicts which can arise in meeting the various users requirements are particularly evident when we consider the FAA airport/terminal surveillance problem. In the preceding sections, we have noted a number of these in

passing. However, since improved weather surveillance in the airport/terminal area will provide the greatest safety benefits, it is worth summarizing the factors in one place. In particular, we have seen that:

(a) Terminal/Airport Coverage and Resolution From Standoff Sites is Inadequate

When geometry is such that the distance from the airport to the nearest NEXRAD site is more than 30 miles, the JDOP system cannot provide even 1 km resolution in the airport airspace (365 m is desired). The best possible low-altitude coverage it could provide is 700 feet and up, assuming the ground clutter and low SNR can be overcome. Five of the top ten airports on the FAA list (and 21 of the top 40) fall into this category with the siting suggested in [6].

(b) Terminal/Airport Performance Using an En Route Sensor Sited at the Airport is Inadequate Due to Clutter and/or Visibility

The MTD experience at Philadelphia illustrates that a JDOP radar sited between 2 and 30 miles from an airport servicing a typical large metropolitan area will have to contend with some very difficult clutter problems in order to provide acceptable low-altitude coverage. The clutter rejection difficulties arise from several strawman radar design features:

- (i) short dwell times (to permit en route volumetric coverage)
- (ii) batch processing (to permit range-doppler dealiasing), and
- (iii) inadequate dynamic range

as well as some environmental features unique to short range Doppler operation in urban areas (e.g., large returns from ground traffic which cannot be rejected by conventional clutter filters). The difficulty with large returns from ground traffic is that they cannot be filtered, even if the system is designed with the approximately 90 dB of dynamic range required to avoid IF saturation. Additionally, at some of these sites, there may not be adequate visibility at low altitudes due to blockage by large buildings. The remaining five of the top ten airports on the FAA list (and 14 of the top 40) fall into this category. For these airports, low-altitude coverage of the terminal and airport airspaces would still be significantly compromised.

(c) En route Coverage From Airport Sites Will Be Significantly Degraded
By Obstacle Blockage and Dwell Time Constraints

A JDOP sensor sited within 2 miles of an airport would in principle be able to cover the low-altitude portions of the associated terminal and airport airspaces. However, the radar would then generally not be optimally sited to provide coverage of the surrounding en route airspace at lower altitudes and longer ranges. In particular, sensors sited at large metropolitan airports would not necessarily be capable of providing acceptable coverage of the cone of silence regions of neighboring NEXRAD sites, whether they are en route sites or other airport sites. Of the three airports in the top forty which have an existing NWS site on the airport, only the one at Oklahoma City is free of obstruction problems.

Additionally, the clutter rejection problems discussed above for nearby sites would apply here as well. If the dwell times were slowed down to permit clear air wind detection and better clutter rejection (e.g., to 1 second per CPI = 6 minutes/revolution), then the volumetric coverage would be significantly degraded.

As a consequence of the above considerations, we have concluded that the use of an airport based radar specifically dedicated to airport/terminal service with the en route service being provided by the JDOP sensors with the suggested siting appears to offer the cost effective approach to providing the desired service in the en route and terminal/airport areas. Such a sensor would use netting of the surrounding NEXRAD sites to provide the full volume scan coverage (on a 5 minute update period), thus freeing the terminal radar to spend more time providing

- 1) High resolution, low altitude surveillance coverage oriented specifically toward detection of hazardous phenomena such as gust fronts and microbursts.
- 2) Periodic monitoring of the approach and departure corridors using low scan rates and long dwell times to make reliable estimates of wind shear and turbulence (hopefully in clear air as well as precipitation), and
- 3) High update rate (30 second) tracking of both reflectivity and Doppler features after detection.

Two key issues which immediately arise are:

- (1) Would the use of a specified terminal/airport radar impact significantly on the radar design/system architecture for en route service (and, the NWS/AWS uses)?

- (2) Could a slightly modified JDOP type radar with appropriate reprogramming for measurement sequencing act as the special terminal/airport sensor?

At first look, it appears that the use of a special radar for the terminal/airport regions would have little impact on the JDOP strawman design since that design is based on a background of radar meteorological volume surveillance similar to that required for the en route application. There may, however, be unforeseen problems in several en route functions, and there may be better ways of accomplishing some goals than via the JDOP design. The next chapter discusses some options in this respect.

The required features for the terminal/airport sensor are much less clear at this point due to uncertainties associated with the clutter environment and with the operationally achievable clear air reflectivity levels. These two factors will heavily influence the radar design as shown in Table 3.4. Unfortunately, many key parameters require additional field testing and/or analysis before a definite conclusion can be reached. Chapter III discusses a number of these issues.

III. SUGGESTIONS FOR FURTHER FAA INVESTIGATIONS

A weather information system based on radar meteorology must take maximum advantage of the capabilities of the coherent radar sensor. At the same time, it is important to realize that this technology introduces some special problems, many of which are familiar to the FAA through its work in aircraft detection for ATC. Experience gained with operational ATC radar systems has shown that a real-time radar data base will contain numerous false alarms caused by ground clutter, ground vehicular traffic, birds, anomalous propagation, etc. These anomalies can and should be dealt with using advanced data processing techniques as opposed to manual intervention by meteorologists.

The FAA requires automated, real-time weather products for presentation to controllers and pilots. To be of value for ATC purposes, these products must convey a concise, accurate picture of the local weather hazards to aviation. The tasks outlined in this section involve the evaluation of radar techniques and processing strategies designed to meet the FAA's objectives. They may be grouped into four categories:

- (i) Assessment of NEXRAD design/detection performance,
- (ii) Investigation of design/detection strategies to meet special terminal area needs,
- (iii) Development of data processing, tracking, and display techniques which provide appropriate FAA weather products, and
- (iv) System architecture issues

The chapter is organized as follows. First, we consider a number of design/detection issues which are common to all three regions of airspace coverage with particular emphasis on the en route sector. The issues considered here are viewed as particularly germane to the NEXRAD basic radar. The next section considers radar design/detection issues which are primarily of concern in the terminal airport regions. Section C considers issues related to feature extraction, tracking and display, while section D considers the relationship of the NEXRAD processing functions to the Center Weather Processor (CWP). The final section suggests how the various issues could be addressed using 1) existing fixed location S-band weather radars, and 2) using a transportable test bed.

A. NEXRAD Basic Radar Design/Detection Issues

In the preceding chapters, a number of potential sources of significant performance degradation were noted regarding the basic volume scan capabilities of the NEXRAD radars. These include:

- (1) weather obscuration due to range aliasing
- (2) fixed object (e.g., buildings, ground, trees) clutter
- (3) clutter from moving scatterers (e.g., aircraft, cars, birds)
- (4) inadequate resolution at long range
- (5) inadequate update rates to yield the desired feature tracking capability, and
- (6) excessive errors due to diffraction (shadowing)

In this section, we seek to identify design features, analytical studies and/or experiments to reduce the effects of these error sources.

1. Obscuration Due to Range Aliasing

Obscuration of weather due to range aliasing has long been recognized as a significant problem in pulse Doppler radar systems^[47]*. Figure 3.1 shows how signals whose range exceeds the radar unambiguous range domain ($R_a = 1.5 \times 10^5$ km/PRF) are folded over so that they appear to lie in the unambiguous range domain. If only a single storm is present, its true range can be ascertained by varying the radar PRF while its spectrum can be analyzed as if it were in the unambiguous range domain. However, when several storms are present, their spectra may overlap which in turn can result in erroneous spectral estimates. Decreasing the PRF to increase the unambiguous range domain is not possible practically since this would lead to excessive Doppler aliasing^[47].

The degree to which obscuration is a significant problem for an automated ATC weather system should be a high priority topic for future FAA weather research since it can have a major impact on radar sensor design. To date, the bulk of the pulse Doppler weather studies have been carried out by research meteorologists who could ignore data sets in which obscuration occurred and/or manually adjust the prf to avoid obscuration in the storm region of interest. Additionally, an automated ATC weather system will require cleaner estimates of Doppler features (especially, spectral width) than would be the case with a meteorologist intensive system.

*The same phenomena can also occur with airport surveillance radars (ASR's). However, the problem there is much less acute since the aircraft targets are discrete targets as opposed to being an extended targets. A discrete target causes obscuration only in a single range cell. Also, the received power from discrete targets typically drop off as R^{-4} , whereas an extended (beam filling) target return power decreases as R^{-2} .

RANGE AND DOPPLER AMBIGUITIES

REFLECTIVITY

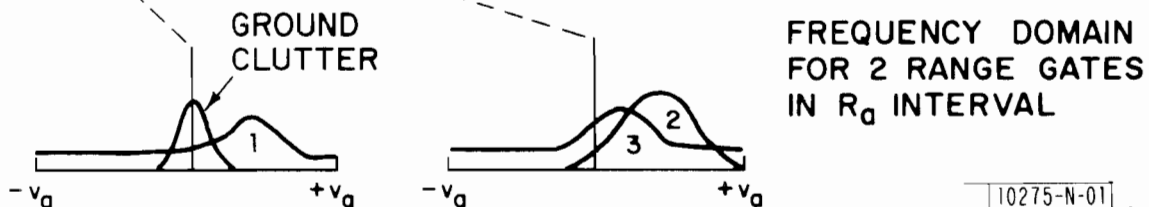
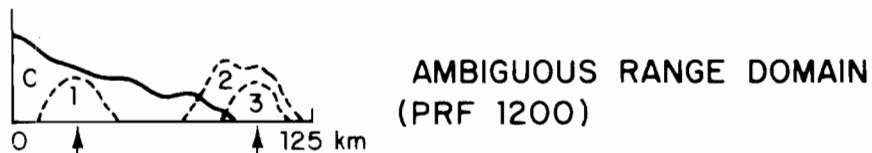
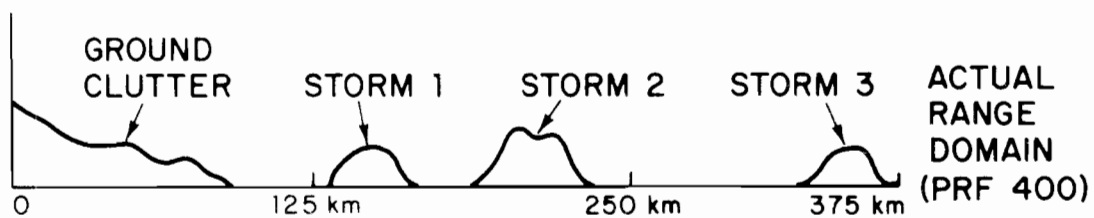

10275-N-01

Fig. 3.1. Storm geometry which leads to obscuration problems with conventional pulse doppler radar systems.

Several solutions have been suggested for alleviating obscuration. The JDOP strawman suggested batch processing whereby periods of interrogations at a high data rate (to furnish unambiguous Doppler data) are followed by periods of low PRF interrogations to furnish unambiguous reflectivity data. Fig 3.2 illustrates this process. By changing the high PRF (based on low PRF reflectivity data), it is argued that the various weather returns can be made to appear at disjoint range intervals in the unambiguous range domain. In the next section, we will see that a major deficiency of this scheme is that the clutter rejection capability for Doppler estimation is reduced by the need to process unequally spaced pulse trains.

A closely related alternative approach under active investigation (by the Air Force Geophysics Laboratory) for NEXRAD is to transmit at two frequencies, one at a high PRF and the other at a low PRF. As in the batch mode, the low PRF results can be used to adjust the high PRF to minimize overlap in the unambiguous range domain.

A significant problem with either scheme is that it may be difficult (or even impossible) in cases of extended weather systems to adjust the high rate PRF so that overlap will not occur in the unambiguous range domain*. If such overlap occurs, sizable errors in the estimates of mean velocity and spectrum width can occur as is illustrated in figure 3.3. Figure 3.4 summarizes how the ability to determine spectral features depends on the relative amplitudes of two overlapping weather returns. The regions in figure 3.4 where only high variance reflectivity data is available corresponds to situations where reflectivity is estimated from low PRF data in the batch mode.

An alternative approach, suggested in [47] and implemented by Lincoln Laboratory is to transmit at a high PRF with a pseudo-random phase change on each transmission. Echoes from second trip storm features can be recovered by appropriate digital processing as is illustrated in figure 3.5. When a zero/PI pseudo-random phase sequence is used, the digital phase adjustment is particularly simple^[57]. With this dual coherent interval (DCI) scheme, overlapped weather from the unambiguous range intervals other than the range interval being processed appear as white noise in the spectral domain. Figures 3.7 and 3.8 present simulated results for the processed spectra in the first and second trip channels when the overlap shown in figure 3.6 occurs. Although the noise floor is increased significantly, the use of spectrum mean and width estimators which do not rely on the zeroth lag autocorrelation value are seen to be quite effective in obtaining good estimates. The advantage of this scheme over the approaches discussed previously are:

- (1) a high PRF is used to estimate all parameters
- (2) no weather dependent PRF adjustments are required, and

*Demonstration of automatic prf adjustment to minimize obscuration should be an important element of the initial NEXRAD NSSL testbed activity.

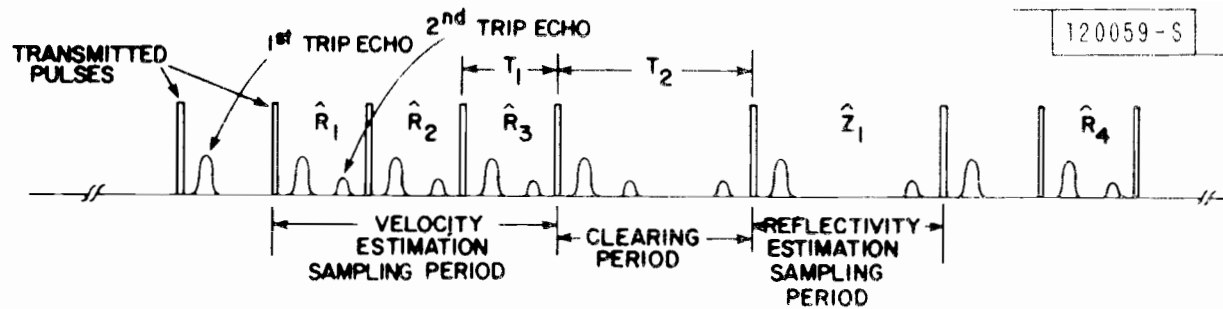

Fig. 3.2. Dual Sampling Technique.

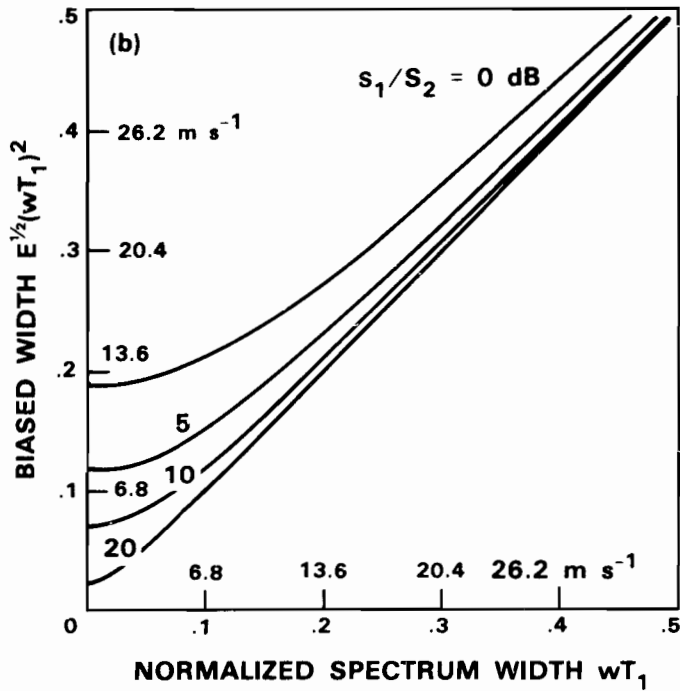
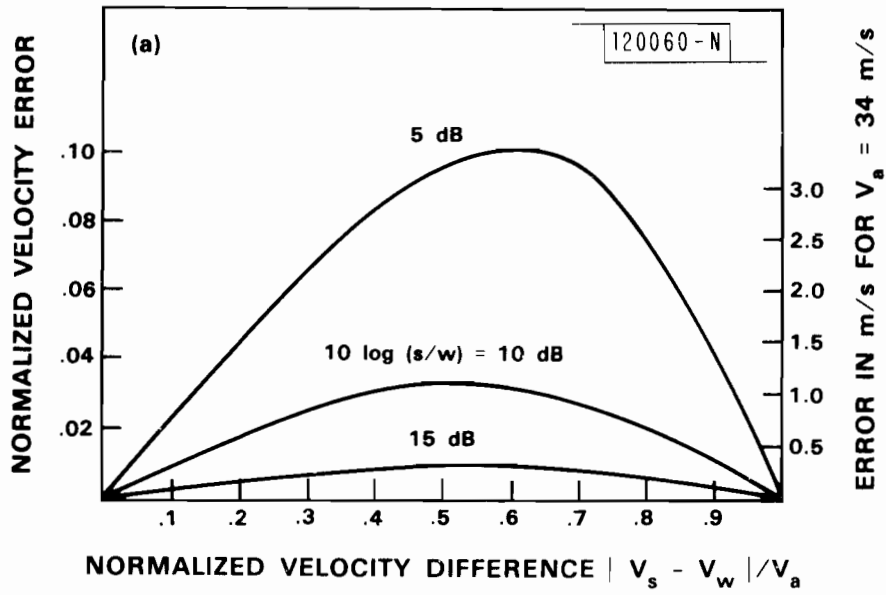

Fig. 3.3. Mean and width velocity errors due to overlap of weather signals.

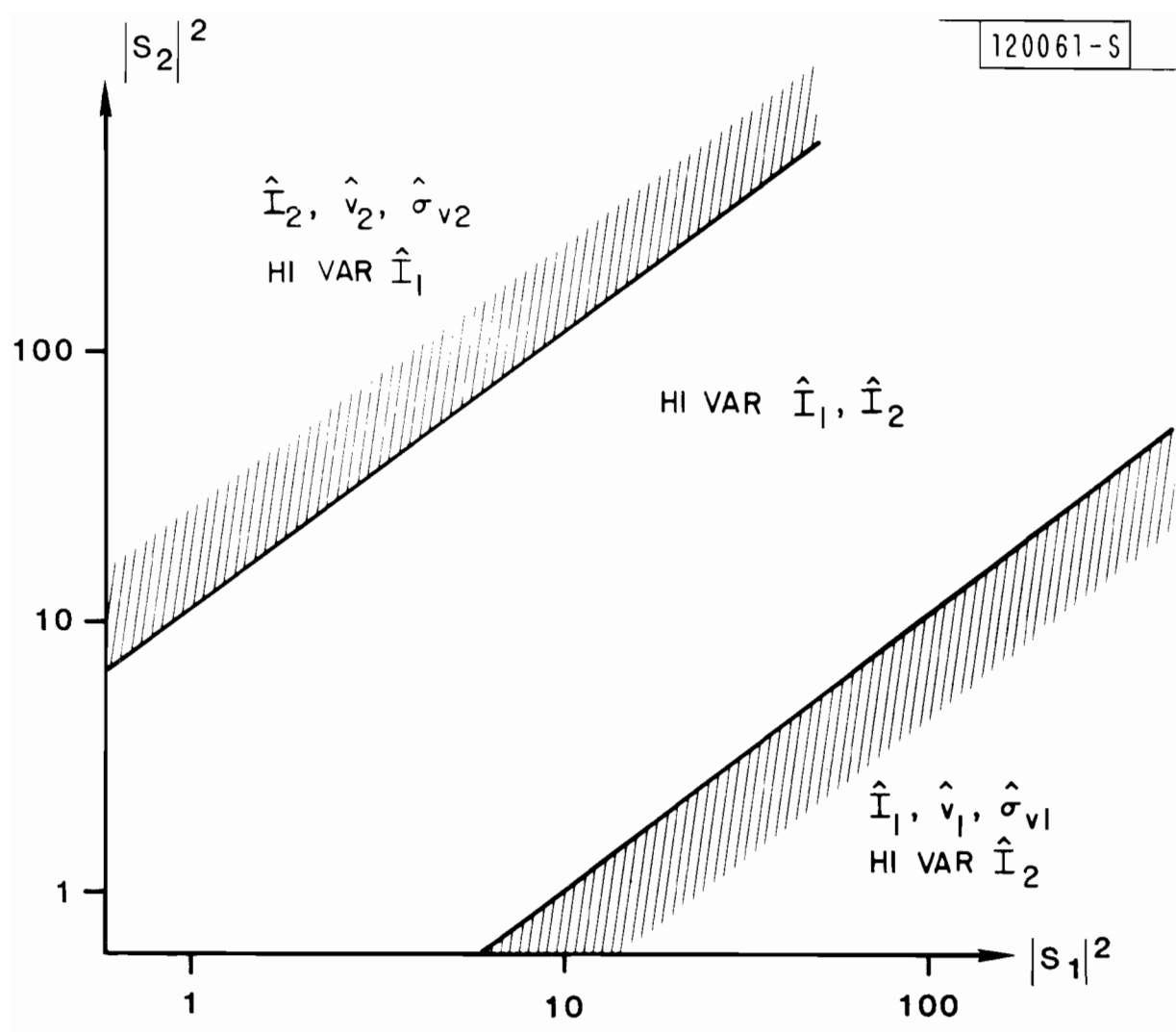

Fig. 3.4. Performance of baseline system when two weather signals overlap.

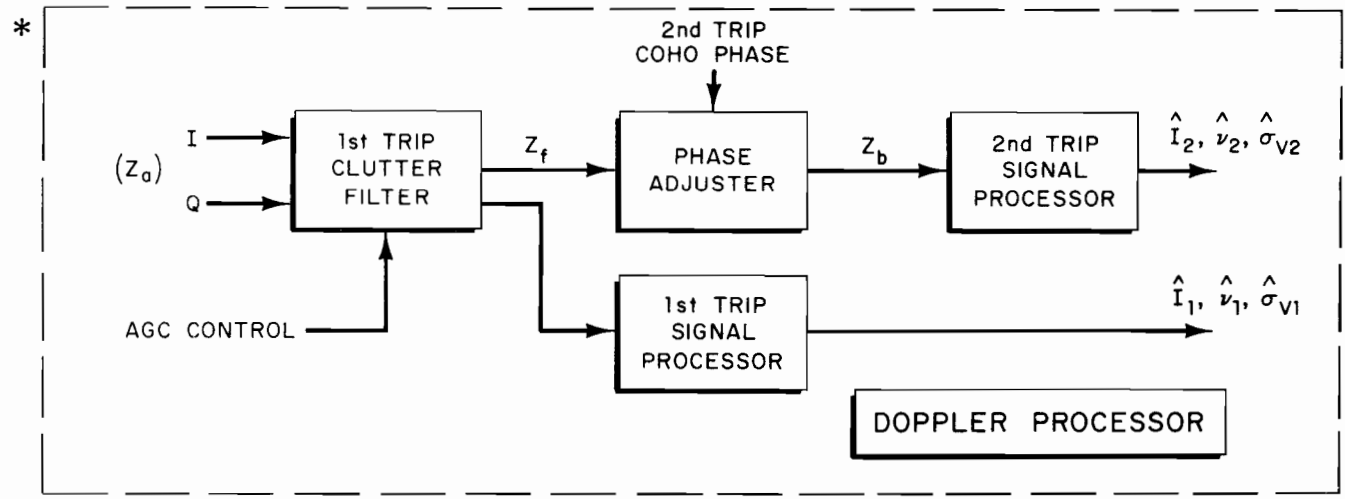
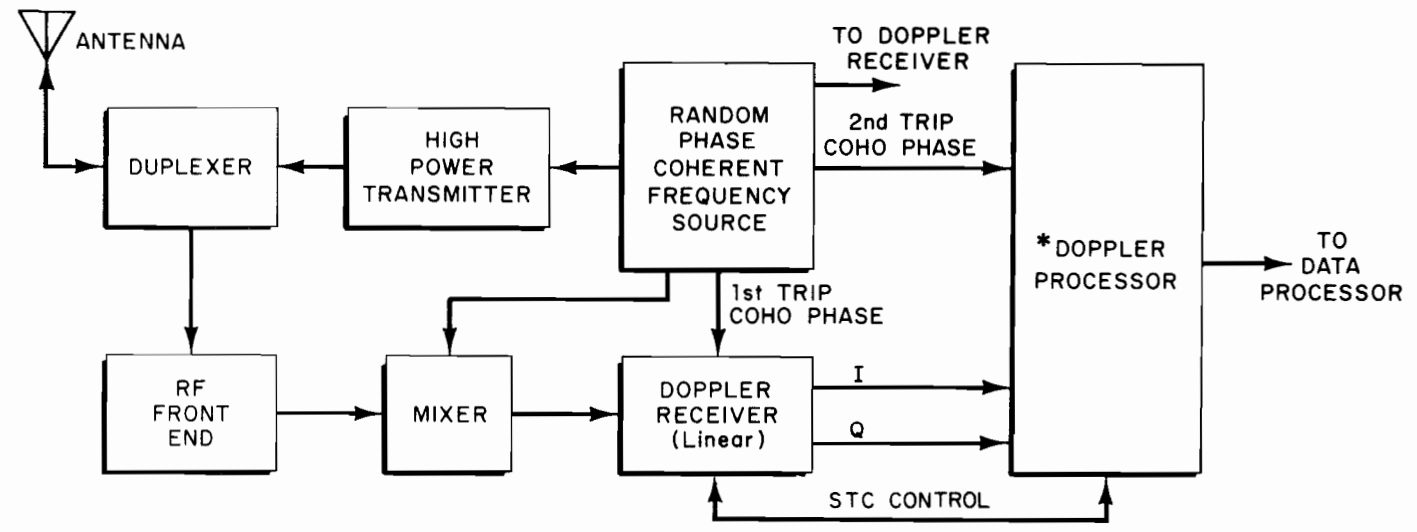

Fig. 3.5. Dual coherent interval system.

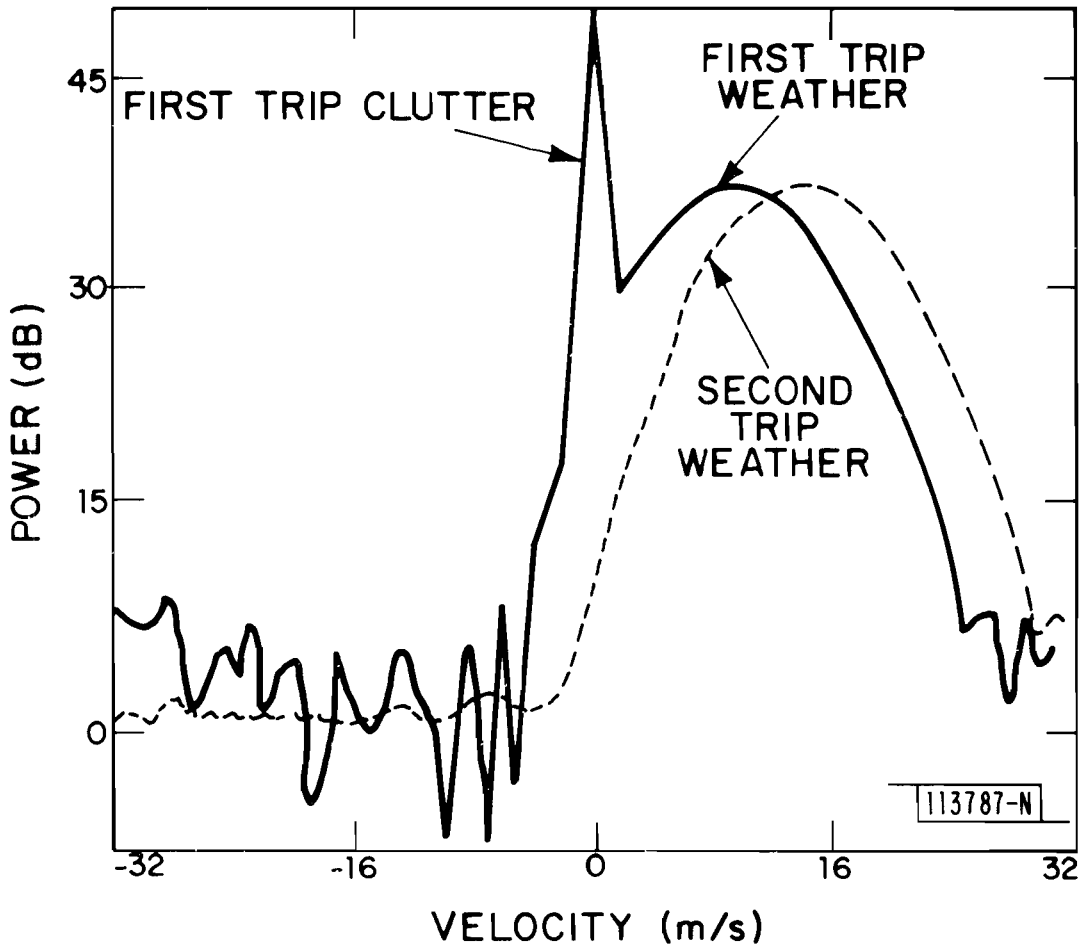

Fig. 3.6. Example of weather obscuration due to range aliasing.

FILTERED FIRST AND SECOND TRIPS — ACTUAL FIRST TRIP SIGNAL

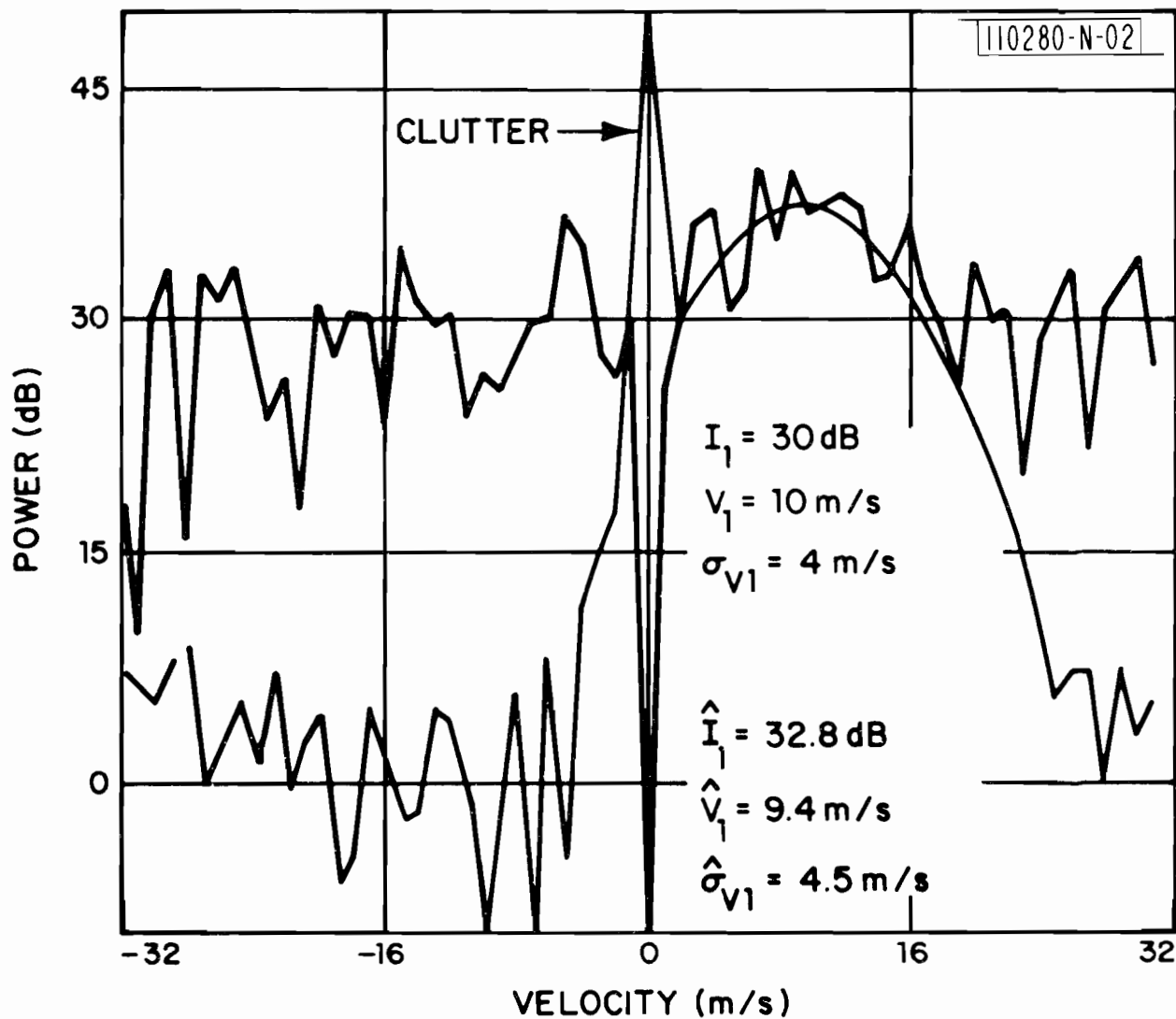

Fig. 3.7. Effects of decohered second trip echo on first trip signal.

RECOHERED ESTIMATE OF SECOND TRIP SIGNAL — ACTUAL SECOND TRIP SIGNAL

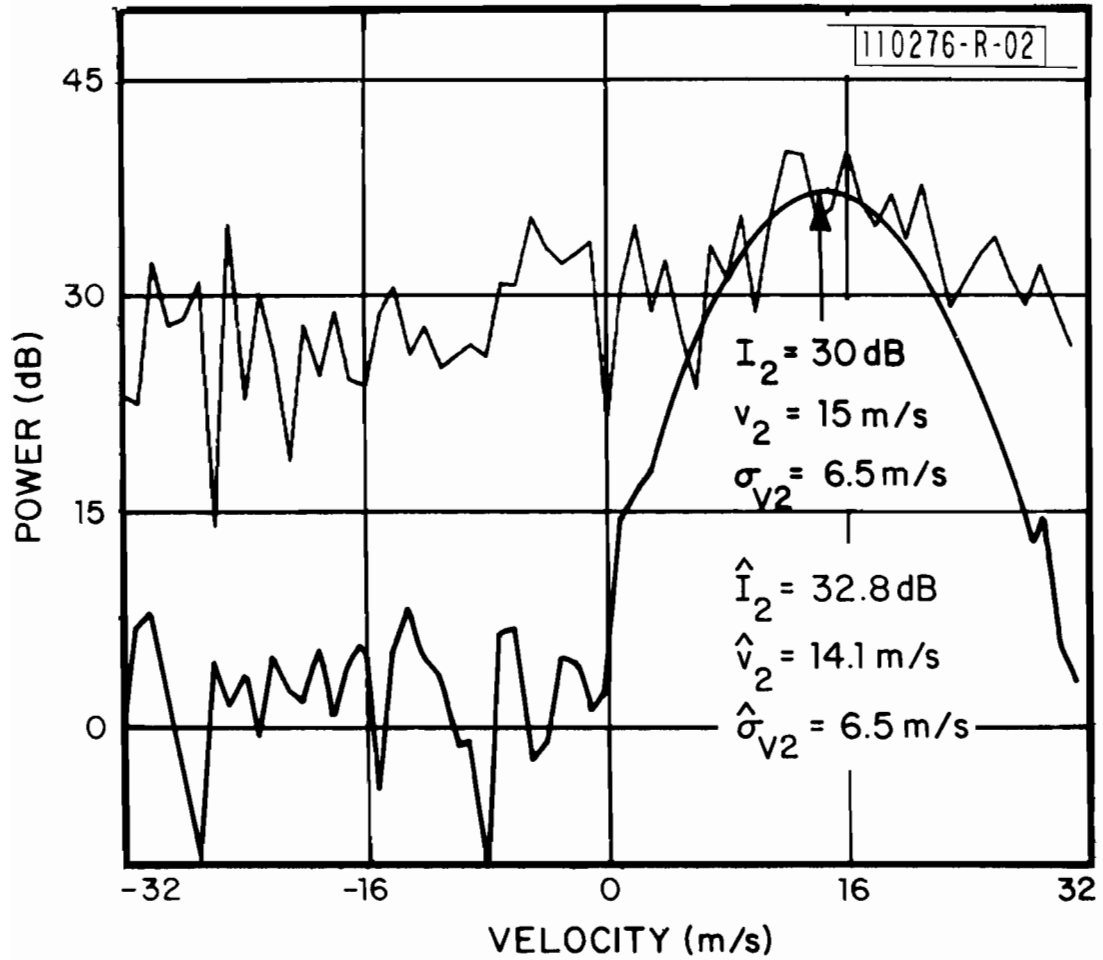

Fig. 3.8. Effects of recoherence and filtering on overlapped first and second trip signals.

(3) a constant PRF facilitates clutter filtering

On the other hand, the first trip clutter filtering does effect the estimation of second trip weather; and, sufficiently large differences in the weather levels will result in loss of all data on the weather return as indicated in figure 3.9.

Another version of the DCI technique transmits orthogonal signals on alternative constant PRF transmissions and processes the various trips in multiple receiver channels as shown in figure 3.10. The orthogonal signal sets should have:

- (a) an autocorrelation function envelope with a small total duration (e.g., $< 2 \mu\text{s}$) or, a large peak to sidelobe ratio (e.g., $\geq 20 \text{ dB}$)
- (b) a cross correlation function envelope which is as small as possible at all lags, and
- (c) identical clutter response after matched filtering.

One possible orthogonal signal set is pulses at different frequencies spaced at least $1/T$ (where T is the pulse width) apart since these have an essentially zero cross correlation function. However, there are several significant problems with this signal set:

- (1) the spectrum occupancy increases proportional to the number of different trips which are to be processed. It might, however, suffice to only consider two frequencies and use the DCI technique to decorrelate the higher order (i.e., third, fourth, etc.) trips since these will have a much smaller received signal level due to the differential range and the difficulty in beam filling.
- (2) the clutter response after matched filtering may not be the same at the various frequencies if there is extended clutter in the given range/azimuth cell.
- (3) the weather response in a given range/azimuth cell may be decorrelated from one frequency to the other. This is quite undesirable for Doppler products.

One could consider separate clutter filters and Doppler processing at the various frequencies; however, the unambiguous Doppler range would then be halved. Consequently, the use of separate frequencies as the orthogonal signal set does not appear feasible.

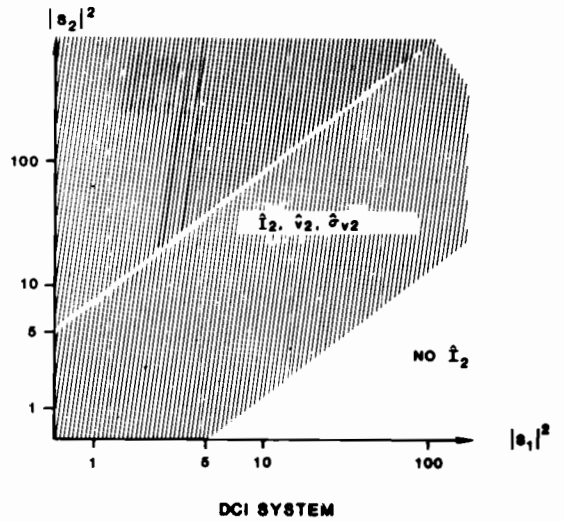
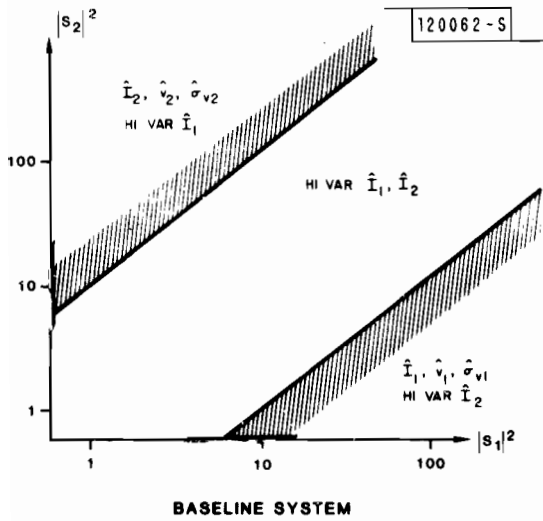

Fig. 3.9. Comparison of system performance in obscuration.

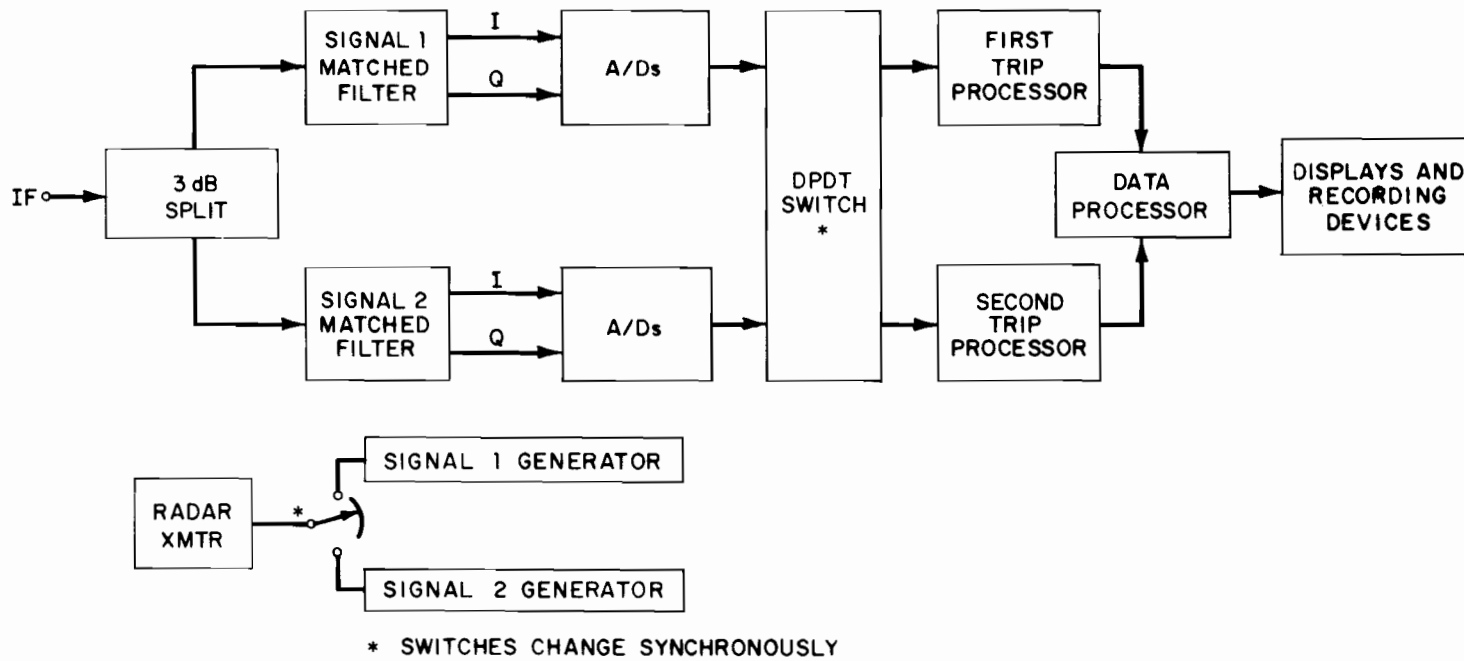

Fig. 3.10. Orthogonal signal radar.

For single frequency operation, one can consider the use of differential phase modulated signal sets where the rf phase between successive signal chips is changed at a rate corresponding to the desired range resolution (e.g., 1 MHz). With these signal sets, one must be concerned with jointly minimizing the autocorrelation and cross correlation function sidelobes since:

- (1) autocorrelation sidelobes cause leakage of weather at adjacent range cells, while
- (2) cross correlation sidelobes can cause obscuration.

Higher cross correlation side lobes are tolerable since phase randomization between successive signal transmissions (i.e., DCI) can be utilized to reduce obscuration. For constant amplitude binary signal sets, the autocorrelation and cross correlation functions for random phase channels are typically bounded by:

$$r_{ii}(n) = \begin{cases} N & \text{for } n = 0 \\ 1 & \text{for } 0 < |n| \leq N \\ 0 & \text{for } |n| > N \end{cases} \quad (3.1)$$

$$r_{ik}(n) = \begin{cases} 1 & \text{for } |n| \leq N \\ 0 & \text{for } |n| > N \end{cases} \quad (3.2)$$

where N is the signal length in chips and n denotes the lag in signal chips.

From equations (3.1) and (3.2), we see that the least achievable autocorrelation sidelobes are on the order of $1/N$. Consequently, it is difficult to achieve very low sidelobes without increasing the signal duration unduly. The effects of autocorrelation sidelobes depend on the distribution of weather along the given radial since the signal to interference ratio (SIR) is:

$$\frac{S(f)}{I(f)} = \frac{|r_{ii}(0)|^2 P_o(f)}{\sum_{n=1}^N \left[P_n(f) + P_{-n}(f) \right] |r_{ii}(n)|^2} \quad (3.3)$$

where $P_k(f)$ = power in a range bin removed k bins from the desired bin.

For uniformly distributed weather [i.e., $P_n(f) = \text{constant}$], the $\text{SIR} = N$ and the bias would be small (e.g., < 1 dB) for $N \geq 20$. The major problem is high level returns for some $n \neq 0$ and low level returns from the desired range

bin. Here, the number of range bins with high level returns becomes critical since the desired bin has a N^2 power advantage over any single other range bin.

The effects of range bin smearing for any given N and signal set can be fairly easily assessed from reflectivity data for a single pulse ($N = 1$). Thus, it should be possible to determine the effects of phase coded waveforms by simulation studies using the existing weather radar data base.

Joint optimization of the signal sets to provide low autocorrelation and cross correlation sidelobes is discussed in refs. [65 - 67]*. No general optimizing algorithm has been proposed, however, numerical optimization has been carried out for binary phase sequences. Somaini^[67] suggests that there exist binary sequence pairs with :

(a) rms autocorrelation sidelobes of $0.4 \sqrt{N}$ and crosscorrelation sidelobes of \sqrt{N}

or (b) rms autocorrelation and crosscorrelation sidelobes of $0.6 \sqrt{N}$

by choice of the optimization metric. Somaini^[67] considers only real time functions, whereas with weather radars one must consider the magnitude of the complex correlation function. It is suggested that an investigation be made of:

- (1) sequences which are optimum for complex autocorrelation and crosscorrelation functions
- (2) potential gain with nonbinary phase codes, and
- (3) affects of range smearing due to the autocorrelation function sidelobes on actual weather data sets.

2. Clutter From Fixed Objects

Clutter rejection has not been a principal concern in much of the past weather radar work (e.g., there is virtually no mention of clutter as a significant problem in a recent review article^[47]) due to (1) the relatively benign environment at the principal Doppler radar sites, (2) manual editing of data by experienced observers, and 3) an orientation toward research studies of weather phenomena wherein data which was contaminated by clutter and/or obscuration could be ignored. By contrast, the Lincoln experience with air traffic controllers in connection with the Moving Target Detector (MTD) for

*Binary sequences which yield the lowest (real) autocorrelation sidelobes for $N \geq 40$ have been determined by Linder^[68]. His "best" sequences for $N > 20$ typically have a peak sidelobe to mainlobe ratio of $3/N$ and a rms ratio of $1.4/N$.

the ASR has shown that numerous false alarms due to clutter are unacceptable in a real time operational (ATC) environment.

The clutter rejection problem is complicated by the interaction of a number of key system factors:

- (1) radar hardware features (e.g., antenna beamwidths and side-lobes, pulse widths, and receiver dynamic range)
- (2) radar measurement strategy (e.g., pulse timing sequence, dwell time, antenna rotation rates)
- (3) characteristics of the weather phenomena to be measured (e.g., minimum signal to interference ratio and averaging time required to obtain acceptable accuracy for moment estimates).
- (4) characteristics of clutter at the sites (e.g., level, time variation, geographical distribution)

The interaction of a number of these factors has been discussed recently by Zrnic' and Hamidi[70, 74] and Groginsky and Glover[68] assuming that spectral estimation would be accomplished by clutter filtering followed by pulse pair estimation algorithms. The principal results can be summarized as follows:

- (a) a constant PRF should be used to permit efficient realization of high performance clutter filters (e.g., yielding 30 - 50 dB of clutter rejection). To achieve this at a constant PRF and still cope with range aliasing may require a two frequency radar
- (b) infinite impulse response (IIR) clutter filters are preferred over finite impulse response (FIR) filters, but will probably require initialization to operate successfully with batch processing, and
- (c) adaptive adjustment of the clutter filter parameters (e.g., based on wind velocity and a range/azimuth/elevation clutter map) may be highly desirable to minimize the loss of valid weather data

In both cases, clutter rejection capability was assessed by simulation studies using synthetic clutter signals (point scatters in the Glover/Groginsky study and a Gaussian process with Gaussian spectrum in the Zrnic'/Hamidi study).

These studies have made important contributions to the clutter rejection features for NEXRAD. However, there still remain a number of important issues which have not been adequately addressed:

- (1) clutter rejection capability with actual radar data has not been quantified. This is viewed as particularly important since the characteristics of actual clutter can differ considerably from that assumed in theoretical models such as used in [68]. In the Lincoln ASR MTD studies^[50] it was found that it is not correct when using a scanning radar to consider only the frequency response of filter banks. Rather, the time domain response is important, because the statistics of the clutter and therefore the scanning modulation residue are not stationary. They would be stationary if the clutter consisted of a large number of random amplitude distributed scatterers. What was actually observed was that the ground clutter is often dominated by large single speculars. Consequently, one must use actual clutter data to determine system performance as was done by Anderson^[71].
- (2) the clutter environment can differ greatly between various sites such that one cannot draw firm conclusions from measurements at one site only. To illustrate this, we compare in figs. 3.11 the clutter environments at the NSSL Norman, Okla. site with those for the MIT Meteorology Department, Cambridge, MA site. The MIT site is seen to have a far greater extent of high level clutter. Past Lincoln Laboratory experience with ASR and beacon systems has shown that measurements at representative sites is the only way to obtain the required clutter and visibility data.
- (3) the impact of higher trip weather return obscuration by first trip clutter has not been considered in detail*. For example, the very high level clutter usually found near the radar typically obscures a small fraction of the unambiguous range area (e.g., < 4% if the high level clutter is within 30 km). On the other hand, this clutter may obscure a fairly large fraction of the total area (e.g., 12% in the case of a 30 km radius for the high level clutter area) if one considers both first and second range intervals. Figure 3.12 shows this for the MIT site.
- (4) the minimum signal levels to be detected need to be further quantified. In particular, there exists considerable uncertainty regarding the levels associated with the hazardous winds (e.g., gust fronts) which often precede precipitation areas,
- (5) the impact of the clutter environment on the overall system dynamic range has not been considered in detail. This relates to issues such as RF and IF dynamic range, number of A/D bits and type of AGC.

*it should be emphasized that obscuration arises with either the JDOP single frequency batch mode or the two frequency mode.

120063-R

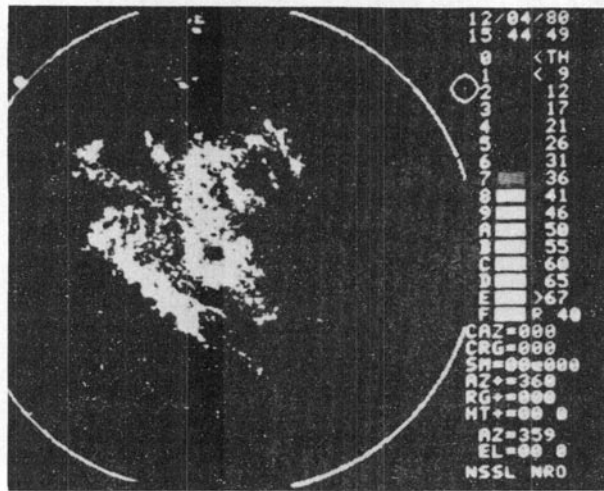

ELEVATION ANGLE = 0.36 deg
0 dB PAD

THRESHOLD = 10 dBz
0.125 nm BETWEEN RG

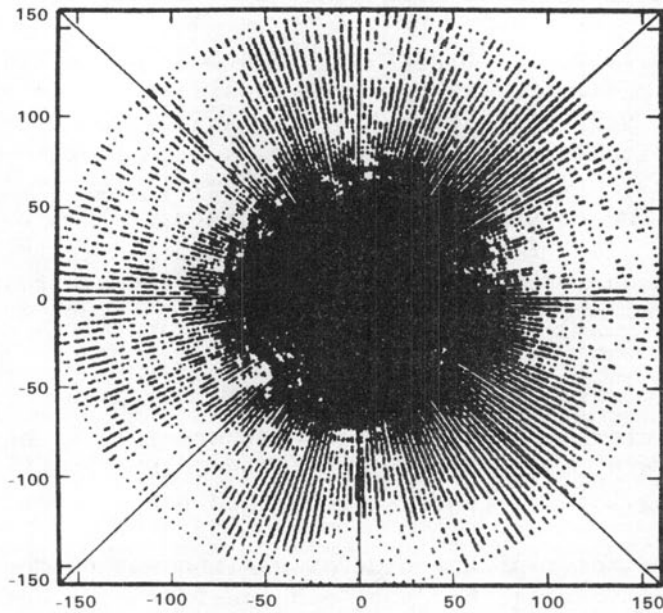

Fig. 3.11a. Comparison of NSSL and M.I.T. clutter levels.

120064-R

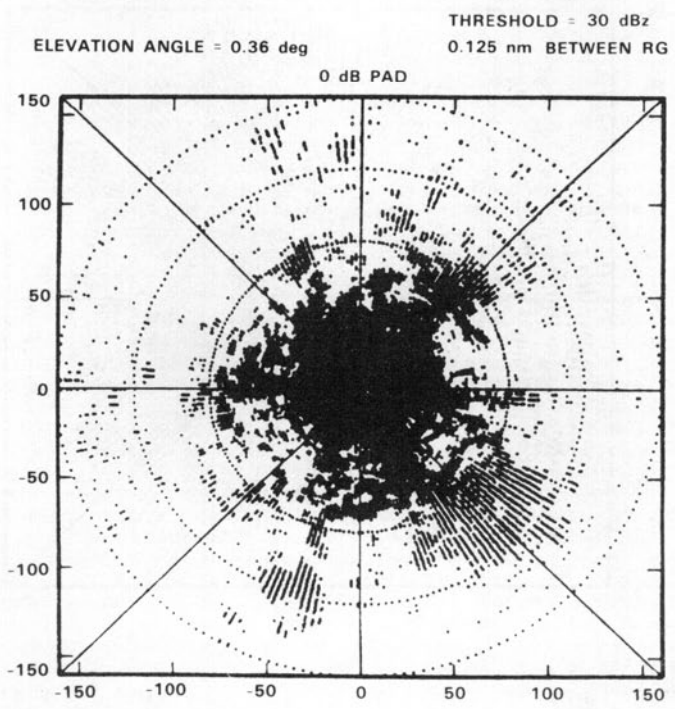
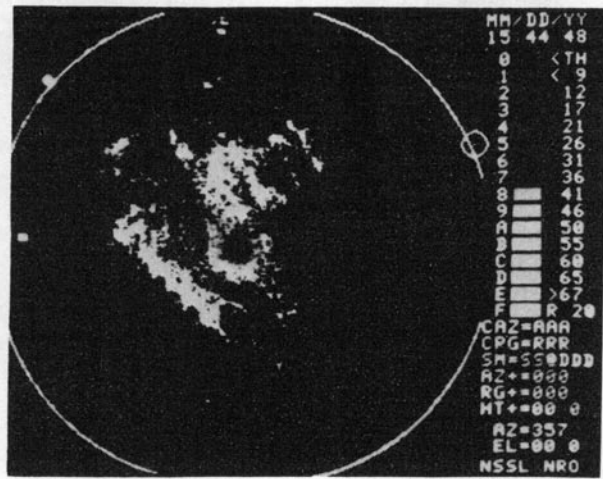
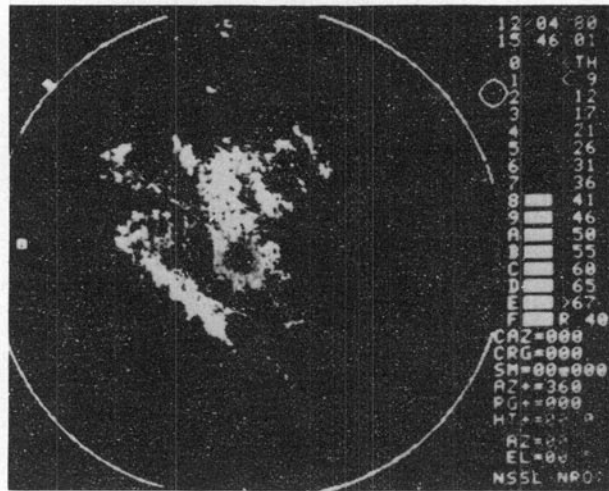

Fig. 3.11b. Comparison of NSSL and M.I.T. clutter levels.

120065-R



ELEVATION ANGLE = 0.36 deg
THRESHOLD = 10 dBz
0.125 nm BETWEEN RG
0 dB PAD

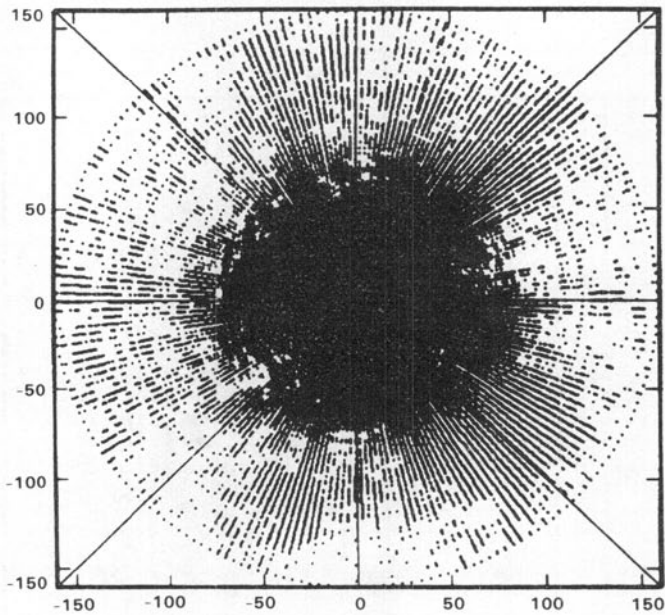
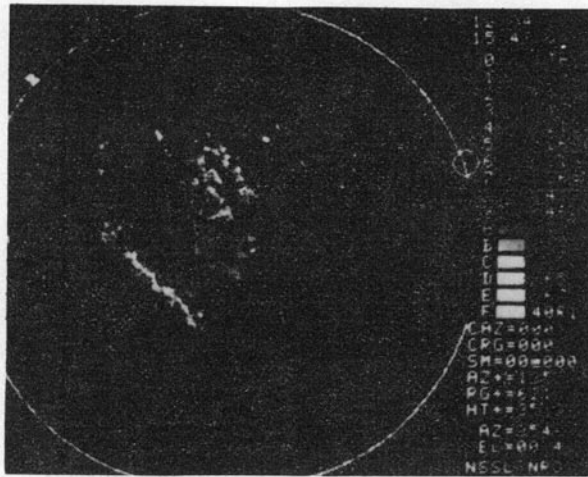

Fig. 3.11c. Comparison of NSSL and M.I.T. clutter data at 0.4° elevation angle.

120066-R



ELEVATION ANGLE = 0.36 deg
THRESHOLD = 30 dBz
0.125 nm BETWEEN RG
0 dB PAD

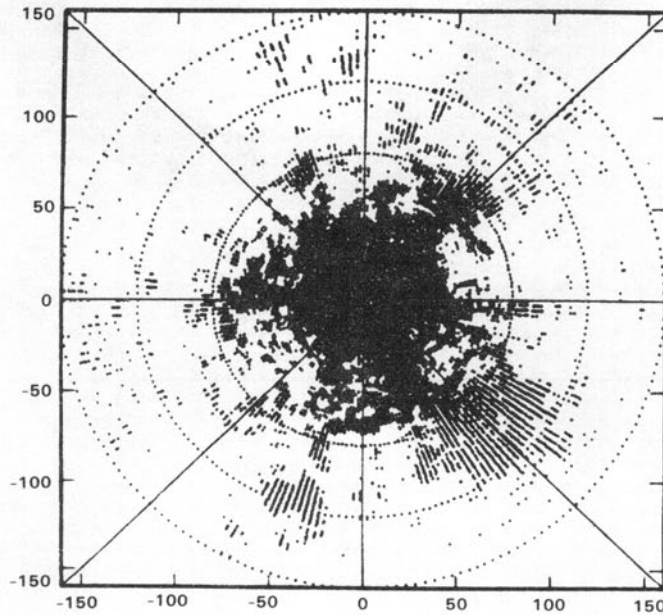
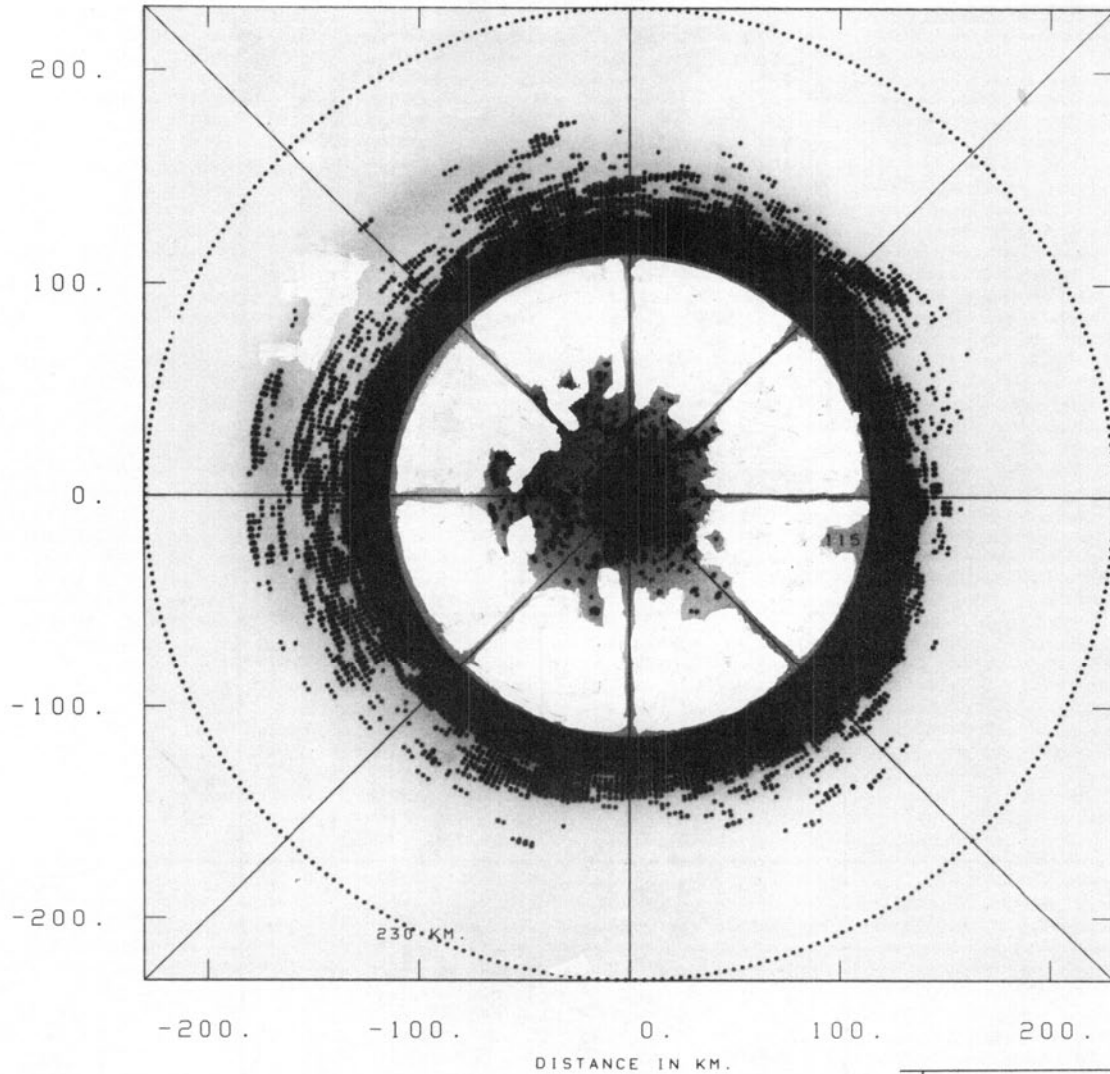

Fig. 3.11d. Comparison of NSSL and M.I.T. clutter data at 0.4° elevation angle.

FILENAME M0715331 FILETYPE CLUTTER THRESHOLD= 30.
ELEVATION ANGLE=0.48DEG. 0. DB PAD .125 NM BETWEEN RG
CLUTTER FILTER DISABLED RPM 2.0



CLUTTER

ATC-112(3.12)

AREA IN KM. THAT EXCEEDS 30.DBZ= 20190.KM**2

Fig. 3.12. M.I.T. site clutter above 30 dBz in the first and second trips.

- (6) clutter rejection techniques which operate in the spectral domain and/or which do not require constant PRF pulse trains have not received detailed examination. It may well be that a combination of such techniques (e.g., full spectral analysis with frequency domain interpolation^[69] at close ranges and low elevations with mean level subtraction^[71] elsewhere) would prove advantageous for batched systems.
- (7) the utility of site adaptive clutter filtering has not been examined experimentally. Since clutter filtering inevitably causes some degradation in weather parameter estimation, there is no merit to using a clutter filter where it is not needed. However, the benefits to be gained from using range/azimuth/elevation selectable clutter filters has not been demonstrated experimentally.
- (8) at short ranges, the NEXRAD range resolution volume size is generally much smaller than the scale size of the pertinent weather hazards. Consequently, it should be possible to utilize interclutter visibility to detect weather features which are masked by the median clutter environment. Again, no operational demonstration of this capability has yet been carried out.

Section D of this chapter discusses how a number of these clutter rejection issues could be investigated using existing radars and with a transportable testbed system. The principal focus should be on the analysis of actual clutter data and the use of this data to compare various clutter mitigation methods.

3. Clutter Due to Moving Objects

Clutter due to moving objects such as cars, aircraft or birds has not received much attention thus far in the NEXRAD weather radar design activity although such scatterers were found to be a major source of false alarms with the MTD ASR processor^[50]. Moving objects are hard to reject because their Doppler frequency may be outside the clutter rejection filter stop band.

Some feeling for the problems posed by such objects can be obtained from the MTD experience [50]. Figure 3.13 shows the bird/aircraft cross section distribution measured at Burlington, VT. Figure 3.14 compares the corresponding signal to noise ratios with those for representative precipitation reflectivities. We see that even small targets (e.g., $\sigma_0 = -20$ dB with respect to 1 m^2) can be comparable to strong weather echoes in the airport/terminal region while aircraft represent a strong weather echo out to the unambiguous range of the radar.

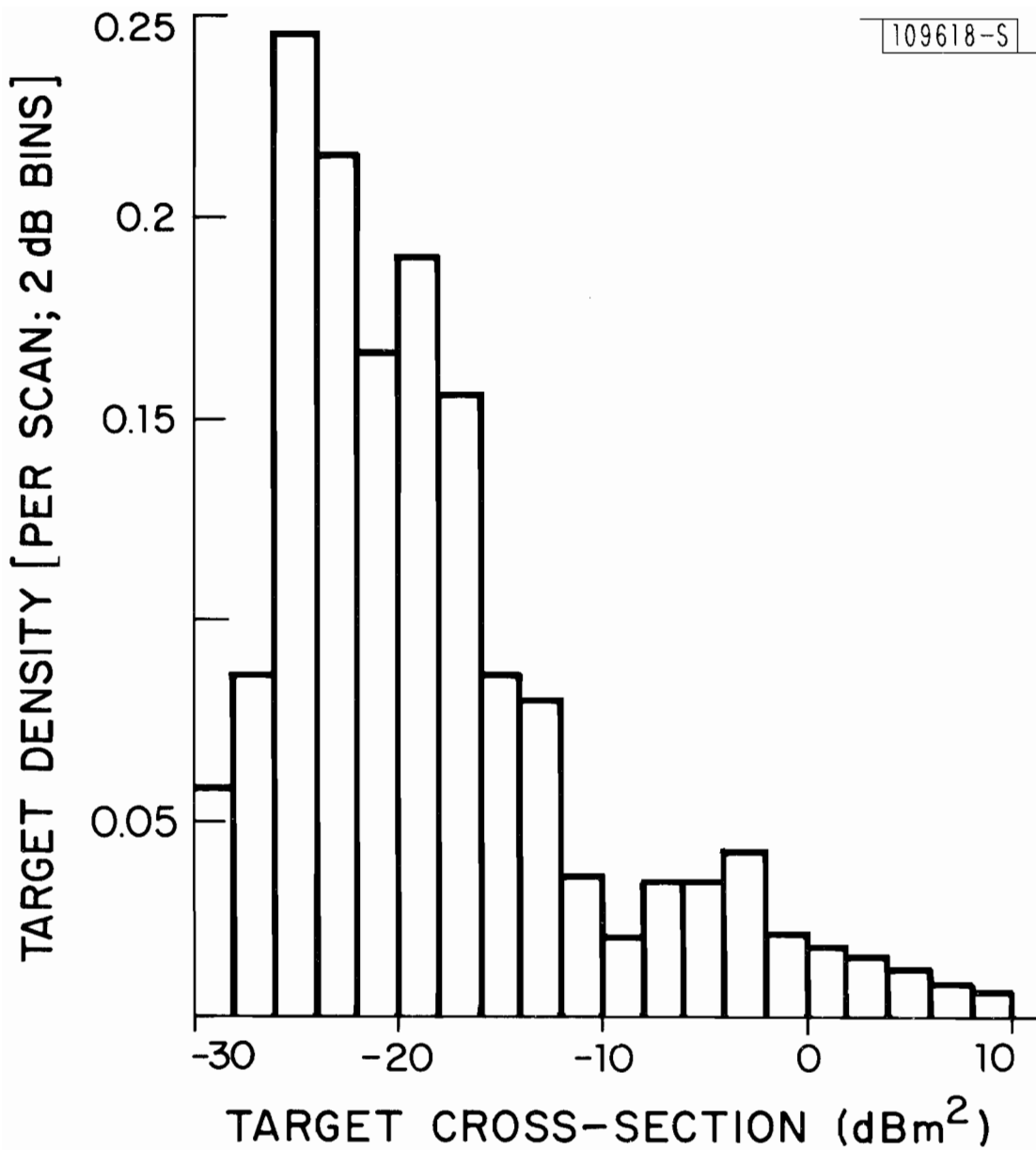

Fig. 3.13. Example of bird/aircraft cross-section distribution at Burlington, VT.

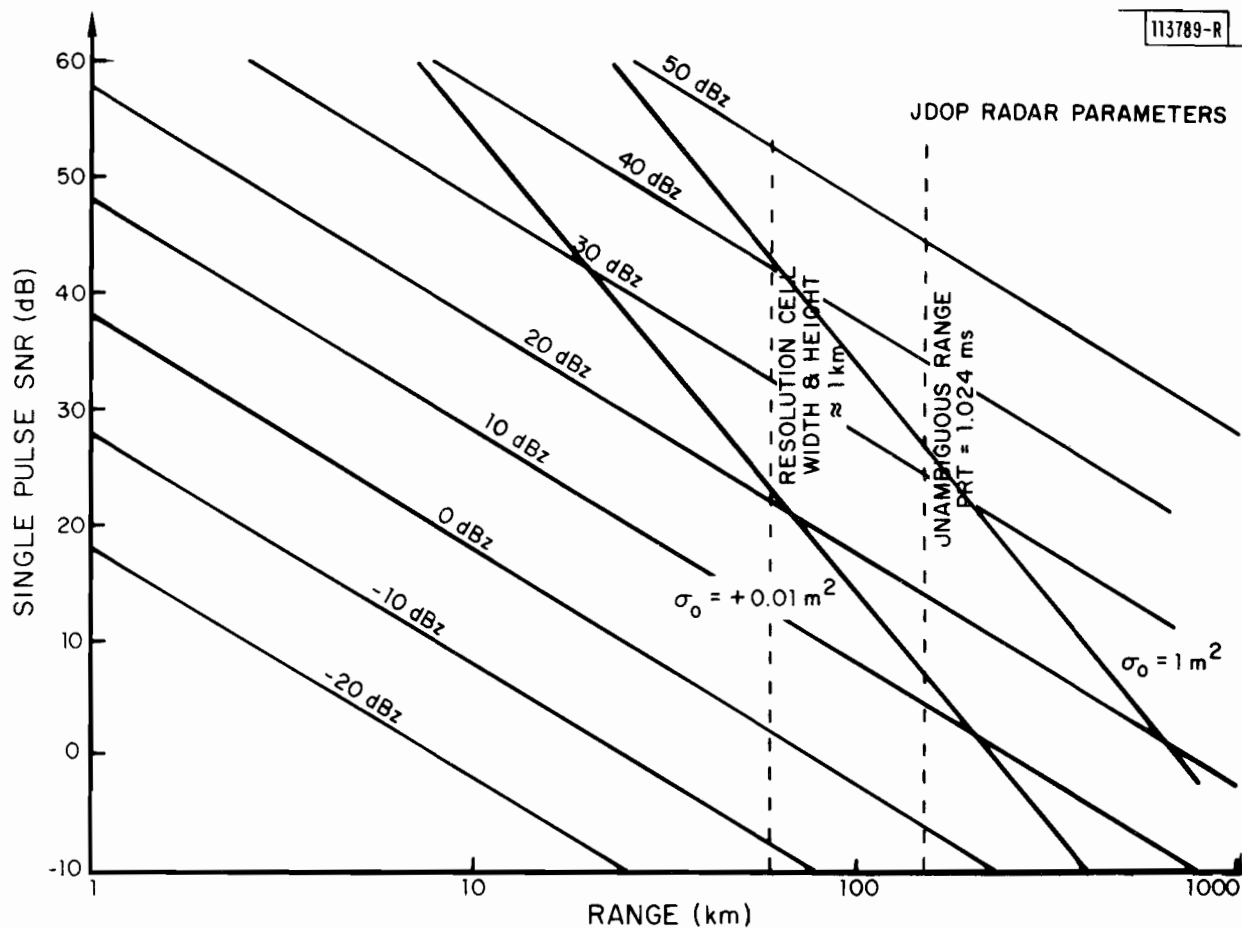

Fig. 3.14. Comparison of weather return SNR with aircraft and bird returns.

Tables 3.1 and 3.2 show that a substantial amount of the MIT site S-band clutter at lower to medium equivalent reflectivity levels has either a mean velocity substantially greater than 1 m/s and/or an apparent spectrum width which is much wider than the 0.1 m/s - 0.5 m/s value typically postulated for NEXRAD [74]. The equivalent reflectivities in the second trip for the clutter would be approximately 20 dB greater than those shown in tables 3.1 and 3.2.

Unfortunately, a number of the algorithms developed^[50] for data editing in the MTD are not applicable to weather radar since they utilized the point target nature of aircraft returns. The discriminants which may be applied in the case of weather include:

- (a) maps of cells which are known to be contaminated by moving vehicles,
- (b) spatial continuity of weather features (principally useful at close ranges), and
- (c) time continuity of weather features.

Based on the MTD experience, it will be necessary to obtain significant operational experience at a variety of sites to determine appropriate solutions to the moving clutter problem.

4. Resolution at Long Range

Although the JDOP strawman weather radar has a sufficient power aperture product to detect strong weather echoes out to several hundred kilometers, it is unclear whether reliable information (for ATC purposes) will be obtained due to the spatial smoothing of weather features in the azimuth and elevation planes. The principal factor used in arriving at a 1° beamwidth in the JDOP study was the mesocyclone detection based on theoretical models for Rankine combined vortex signatures (figure 3.15) together with empirical measurements of mesocyclone diameters (figure 3.16). Unfortunately, these data are only a part of the story since one must also consider the extent to which other weather could appear to be a mesocyclone.

From an ATC viewpoint, reliable detection of heavy precipitation at long range may be even more important and this apparently has not been investigated to date. It is suggested that simulation studies be carried out in which actual weather data obtained at close ranges (where the resolution is adequate) is then viewed by a synthetic radar located some distance away. The observed weather in each range/azimuth/elevation bin for the synthetic radar would be an antenna pattern-range weighted superposition of the actual radar range/azimuth/elevation bin data. By repeating this process at various

TABLE 3.1
 DISTRIBUTION OF M.I.T. CLUTTER MEAN VELOCITIES
 AT CLOSE RANGE

REFLECTIVITY (dBz)	PERCENTAGE WITH MEAN VELOCITY (m/s)					
	0 - 1	1 - 2	2 - 3	3 - 5	5 - 10	>10
<20	70.0	11.6	6.1	5.6	4.9	1.7
20 - 40	91.4	2.2	2.1	1.9	1.5	0.8
40 - 60	99.7	0.1	0.1	-	-	-
>60	100.0	-	-	-	-	-

5 nmi < RANGE < 10 nmi

TABLE 3.2
 DISTRIBUTION OF M.I.T. CLUTTER SPECTRAL WIDTHS
 AT CLOSE RANGE

REFLECTIVITY (dBz)	PERCENTAGE WITH SPECTRUM WIDTH (m/s)					
	0 - 1	1 - 2	2 - 3	3 - 5	5 - 10	>10
<20	46.9	27.6	12.3	12.0	5.9	0.3
20 - 40	70.6	20.5	4.1	3.3	1.5	-
40 - 60	86.2	13.6	0.1	-	-	-
>60	94.5	-	-	-	-	-

5 nm < RANGE < 10 nm

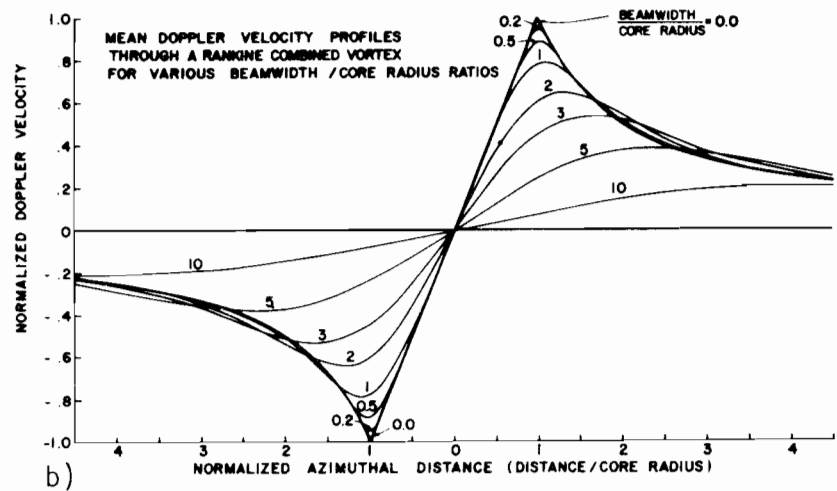
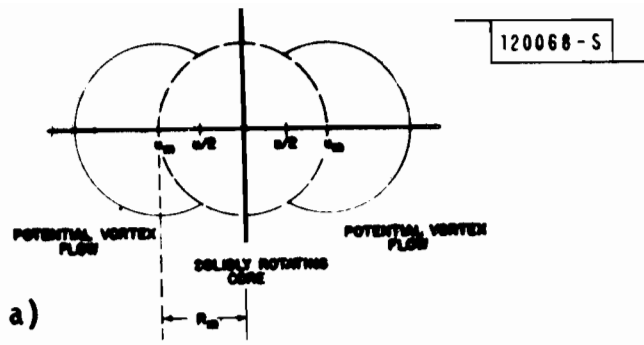

Fig. 3.15. (a) Single doppler horizontal mesocyclone signature of a stationary rankine combined radius. (b) Theoretical mean doppler velocity azimuthal profiles through a rankine combined vortex.

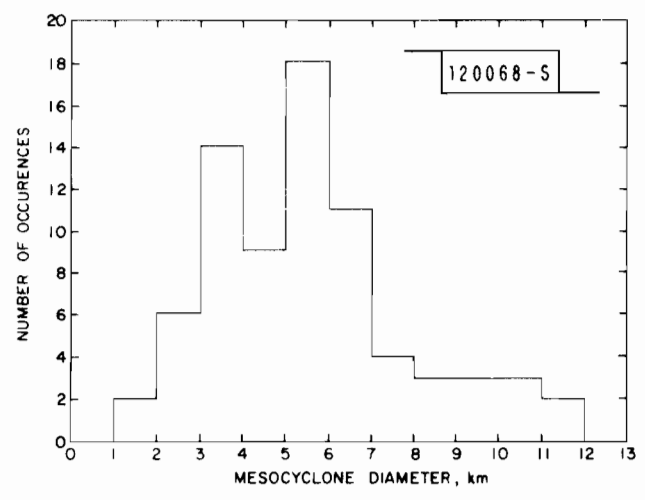

Fig. 3.16. Frequency of occurrence of measured mesocyclone diameters.

locations for the synthetic radar, it should be possible to quantitatively assess the performance degradation as a function of range.

5. Inadequate Update Rates

The NEXRAD volume scan update rates have been of concern for some time since some weather features can change and/or move rapidly over short periods of time. From an ATC viewpoint, this would be of greatest concern in the terminal/airport region. However, in this region, the various elevation scans are fairly close in height above ground so that an interlaced scan (such as suggested in [24]) will provide a higher effective update rate.

Simulation studies using actual weather data obtained at a high data rate (e.g., via limited sector scans in azimuth and/or elevation) seem to be the most attractive way to assess the utility of higher rates. By deleting some fraction of the actual data (e.g., using 1/M of the actual scans) one can quantitatively determine the utility of the missing data.

6. Performance Degradation Due to Diffraction

Diffraction effects, as discussed in Chapter II, should be a factor in site selection, and will probably affect the number of radars which must be purchased.

Simulation studies of the effects of diffraction on the estimated weather patterns at various specific sites could be carried out fairly easily at the FAA Technical Center*, but need not be a high urgency task until the operational deployment of NEXRAD is imminent. However, if it is decided to accomplish en route and airport/terminal service by a single NEXRAD radar located on the surface of the major airports identified in appendix A, then studies of the en route performance degradation due to shadowing at these airports should be carried out as soon as possible.

B. Terminal/Airport Radar Design/Detection Issues

In Chapter II we noted that the terminal/airport environment differs significantly from the en route sector in that high quality information on low level wind shear (LLWS) and turbulence features is a necessity; and, there may be a high likelihood of encountering such hazards without precipitation in the same spatial volume. Another distinguishing characteristic of the airport/terminal environment is the need for faster update rates since the aircraft have much less flexibility in their choice of flight path (especially when making precision approaches) and decisions to use a given path are typically made over short time periods (e.g., 1-5 minutes) as opposed to the longer time periods (e.g., up to an hour) characteristic of en route flight routing.

*The MLS propagation model^[77] currently in use at FAATC for MLS studies could easily be modified to predict shadowing effects on weather radars.

Issues of concern regarding the JDOP strawman applied to the terminal/airport area include:

- (1) likelihood of occurrence and detectability of LLWS
- (2) clutter rejection capability, and
- (3) update rates

In this section, we identify studies which should be carried out to resolve these various issues.

1. Likelihood of Occurrence and Detectability of LLWS with Pulse Doppler Radar

The likelihood of encountering LLWS has been under active study by NASA and the FAA for many years and at least eight systems (see table 3.3) have recently been investigated for LLWS detection. The detection characteristics of a number of these are reviewed in the Joint Airport Weather Studies (JAWS) project proposal^[81] and hence need not be discussed here. It is fair to say that the likelihood of LLWS occurring with and without concurrent precipitation has not been quantified carefully to date*.

In particular, it has been suggested^[58, 81] that short lived small scale phenomena (such as Fujita's^[48] microbursts) may be as important or more important from the viewpoint of aviation safety than large scale LLWS events such as gust fronts. Many of the issues surrounding the time evolution and radar signatures of microbursts are to be examined in the JAWS project and hence we will not discuss them here.

However, it should be noted that a number of key issues related to operational LLWS detection by NEXRAD type radars will not be addressed by JAWS in its proposed form^[81]:

- (1) It is unclear how the probability of detection and probability of false alarm for hazardous winds will be assessed. In particular, it appears that two C-band pulse Doppler radars will be a principal means of detecting hazardous wind characteristics. The C_n^2 measurements in the Denver region by Chadwick, et.al. [82] and figure 2.9 suggest that the detection range of such radars may be quite small for clear air winds. An anemometer array will also be available to JAWS, but it has

*The JAWS proposal^[81] indicates that microbursts occurred 2 1/2 times more frequently than gust fronts in project NIMROD.

TABLE 3.3
LLWS DETECTION SYSTEMS

1. Airborne air speed and ground speed procedure
2. Ground based microwave pulsed Doppler radar
3. Ground based wind shear alert system (LLWAS) using airport centered arrays of anemometers
4. Ground based "pressure jump" alert system
5. Airborne wind shear computer using:
 - (a) an inertial navigation system to determine ground speed
 - (b) an airborne wind measurement system, and
 - (c) threshold wind velocity
6. Airborne CO₂ laser velocimeter
7. Ground based acoustical radar
8. Ground based laser radar

been noted repeatedly^[81] that the greatest severity hazardous winds tend to be at altitudes below 100 meters. Aircraft could be used to probe these regions, but this could be hazardous to the aircraft if dangerous shears or down drafts exist and, the JAWS proposal suggests that the aircraft will primarily be used to develop airflow and thermodynamic properties. Assessment of false alarm probabilities requires a defined LLWS detection algorithm using pulse Doppler radar. It is uncertain from [81] whether such an algorithm will be used and the extent to which data without LLWS will be analyzed with candidate algorithms.

- (2) Extension of the JAWS results to other areas (e.g., the southeast or east coast) may be difficult due to the particular characteristics of the Denver weather. For example, the SNR values on clear air LLWS in the Denver area may be significantly lower than those for other areas (recall figure 2.9); and, the thunderstorm generation/propagation mechanisms may differ.
- (3) Quantitative assessment of the need for LLWS detection capability in the absence of precipitation does not appear to be a principal objective of the study. This issue is particularly important for the FAA terminal/airport region since clear air detectability will place very stringent requirements on the radar sensor parameters.

The comments above should not be viewed as a criticism of the JAWS project concept in terms of its proposed objectives; but rather, are intended to highlight some of the difficulties that will arise in extrapolating the JAWS data to provide proof of concept for a nationwide operational FAA airport/terminal LLWS detection system.

From the discussions in chapter II and above, we conclude that despite many years of LLWS studies, there still exists a lack of quantitative data on:

- (1) the appropriate values of reflectivity (i.e., C_n^2) which would be used for conditions where LLWS occurs,
- (2) the need for clear air detection of LLWS by a weather radar, and
- (3) experience with automated pulse Doppler LLWS detection systems to determine false alarm probabilities.

Developing an operational LLWS detection system using a NEXRAD like radar will necessitate obtaining relevant data at a number of geographic sites over a considerable time period.

One means which should be investigated involves the use of instrumented meteorological high towers* to routinely measure C_n^2 , wind speed and direction at the altitudes (e.g., 100 m - 700 m) which appear to be of greatest concern. Use of these in the vicinity of a NEXRAD type like weather would provide a means for determining LLWS false alarm and detection statistics without the cost, logistics and safety problems involved in aircraft measurements of LLWS. However, we should stress that useful data could be obtained from the towers in regions (e.g., Atlanta, Washington, D.C.) which do not have a pulse Doppler weather radar in the vicinity.

Aircraft measurements have the advantage of being able to cover much larger areas and hence are particularly useful for highly localized phenomena such as microbursts. Thus, aircraft (or perhaps, drones) should be utilized when possible.

One investigation which does require use of a radar involves the likelihood of encountering clear air LLWS when substantive weather echoes are present at other azimuths in the same range bins. This is important for radar sidelobe specification since there is an enormous difference (e.g., 50 - 80 dB) in precipitation reflectivity versus that for clear air.

2. Clutter Rejection Capability

The principal clutter rejection issues for the en route region apply to the terminal/airport region as well. The principal differences here are:

- (a) probable need for greater clutter rejection capability due to the lower SNR for clear air detection and the localized nature and time duration of some phenomena (e.g., microbursts),
- (b) greater need for site specific measurements of the clutter environment, and
- (c) probable need for greater immunity to sidelobe leakthrough and/or obscuration by higher order trip weather.

Since the principal need for terminal/airport service is at a relatively small number of airports, clutter measurements at a representative subset of the airports is essential.

The degree to which ASR data from these airports can be used to provide first order clutter estimates should be investigated. However, it is likely that measurements with a representative pencil beam radar will be needed.

3. Update Rates

The update rates needed in the terminal area to support the desired capability are critical for specification of the radar sensor. The lack of significant experience with an automated terminal/airport weather tracking/prediction system has made it quite difficult to delineate the detection update rate tradeoff. However, it seems likely that short lived phenomena such as microbursts will be the driving factor in determining the required update rate.

The JAWS project should provide useful data on such phenomena in the Denver area, but this needs to be complemented with data from other geographical locations (e.g., midwest, southeast and east coast) which also have severe convective weather at airports.

4. Terminal Sensor Hardware

We have seen that the use of an airport based radar specifically dedicated to airport/terminal service with the en route service being provided by the JDOP sensors with the suggested siting appear to offer the cost effective approach to providing the desired service in the en route and terminal/airport areas. Such a sensor could use netting of the surrounding NEXRAD sites to provide the full volume scan coverage (on a 5 minute update period), thus freeing the terminal radar to spend more time providing:

- 1) High resolution, low altitude surveillance coverage oriented specifically toward detection of hazardous phenomena such as gust fronts and microbursts.
- 2) Periodic monitoring of the approach and departure corridors using low scan rates and long dwell times to make reliable estimate of wind shear and turbulence (hopefully in clear air as well as precipitation), and
- 3) High update rate (30 second) tracking of both reflectivity and Doppler features after detection.

Two key issues which immediately arise are:

- 1) Would the use of a special terminal/airport radar impact significantly on the radar design/system architecture for en route service (and, the NWS/AWS uses)?
- 2) Could a slightly modified JDOP type radar with appropriate reprogramming for measurement sequencing act as the special terminal/airport sensor?

At first look, it appears that the use of a special radar for the terminal/airport regions would have little impact on the JDOP strawman design since that design is based on a background of radar meteorological volume surveillance similar to that required for the en route application. There may, however, be unforeseen problems in several en route functions, and there may be better ways of accomplishing some goals than via the JDOP design.

The required features for a special terminal/airport sensor are much less clear at this point due to uncertainties associated with the clutter environment and with the operationally achievable clear air reflectivity levels. These two factors will heavily influence the radar design as shown in Table 3.4. Unfortunately, many key parameters require additional field testing and/or analysis before a definite conclusion can be reached.

C. Feature Extraction, Tracking, and Display Issues

A significant feature of the FAA use of NEXRAD data will be its emphasis on the accurate generation of higher level weather products. This is because the only type of output from a weather information system that can have more than strategic value for air traffic control is tracked hazards, since hazards that cannot be tracked will not be dealt with effectively by ATC's or pilots.

The fundamental premise concerning severe weather hazards is that they evolve on a scale of minutes, not seconds. Therefore, the growth and behavior of these hazards may be monitored by using a sensor with sufficiently high probability of detection and update rate. Any combination of sensor(s) and processing that meets these requirements will face two difficult tasks: false alarm suppression and data compression. These two tasks make up the bulk of what is referred to as data acquisition and analysis (DAA) processing.

Issues related to DAA processing include:

- (a) false alarm reduction by fixed clutter and moving traffic maps
- (b) false alarm reduction by inter-scan spatial correlation
- (c) scan-to-scan correlation to permit data de-skewing
- (d) contouring and 3-D centroiding algorithms
- (e) tracking of reflectivity cells, and
- (f) feasibility of turbulence feature extraction and tracking using spectrum width (σ_v)

Additionally, one must be concerned with the coordinated display of ATC information and (tracked) weather features as well as the netting of sensors to provide coverage of cone of silence and shadowed regions.

TABLE 3.4
 IMPACT OF RADAR SENSOR PARAMETERS ON KEY
 AIRPORT/TERMINAL SENSOR PERFORMANCE FACTORS

Radar Sensor Parameter	Clutter Rejection	Impact on		Comment
		Hazardous Wind Detection Capability In Absence of Precipitation		
Pulse Width	some	yes		long pulses improve SNR, shorter pulses may yield intra clutter visibility
Dwell Time	major	major		long dwells yield better estimate averaging and clutter rejection
Transmitter Power	no	major		higher power improves SNR
Beamwidth	some	some		narrower beams improve SNR, but may shorten dwell times
Antenna Sidelobes	yes	yes		lower sidelobes reduce clutter effects
Transmitter Pulse Phase Diversity	no	some		reduces effects of range aliasing (obscuration)
PRF	no	yes		high prf permits more averaging of receiver noise, but may increase obscuration
Noise Figure	no	some		low noise figure improves SNR
Frequency	no	some		longer wavelengths have slight advantage

The essential step in addressing all of the issues is to obtain significant operationally oriented experience using a representative radar at representative sites. Lacking this operational experience, it will be extremely difficult to specify the data processing requirements for the system and assess hardware proposals.

Below, we comment briefly on each of the items identified above.

1. False Alarm Reduction by Fixed and Moving Target Clutter Maps

The experience with MTD system^[50,83,84] has shown that the use of maps of clutter from fixed and moving targets are essential for reducing the number of false alarms in an automated tracking system. However, such techniques have not been used to date in deleting erroneous data from weather radar displays, and many of the specific MTD techniques are not directly applicable to weather radar*.

One key issue here is diurnal and seasonal variation in these maps. Anomalous propagation will also represent a significant challenge at low elevation angles. In both cases, measurements at a variety of sites will be necessary to develop a satisfactory solution.

2. False Alarm Reduction by Interscan Spatial Correlation

Scan to scan correlation should be particularly helpful in rejecting transient phenomena such as bird flocks or aircraft which cannot be rejected on the basis of a single scan's results. For example, aircraft will move at a high ground velocity while birds will probably not correlate at higher or lower elevation angles. However, considerable practical experience will be needed to determine the algorithms which can reduce these false alarms without discarding important weather features such as rapidly growing new cells.

3. Scan to Scan Correlation, Contouring, Centroiding and Feature Tracking

The correlation of azimuth scan results at various elevations and times is essential for automatic weather feature tracking and prediction. The major problem in carrying out this process is the need to account for weather feature movement and growth/decay of echo characteristics between various scans. Algorithms for accomplishing this in the context of automatic weather feature prediction have been described by Crane^[45,85] and Bjerkaas and Forsyth^[86,87]. Crane's paper reviews a number of alternative correlation approaches.

Tracking and prediction of high reflectivity (i.e., heavy precipitation) contours probably will be the top priority item for initial automated FAA use

*for example, the MTD DAA algorithms sought to avoid displaying weather returns.

of NEXRAD products. Unfortunately, neither of the tracking algorithms mentioned above has yet been shown to reliably predict contours of high reflectivity. Bjerkaas and Forsyth^[87] track contours of fixed reflectivity, but the resulting errors are often comparable to the distance moved by the contour between successive scans^[86]. Crane's approach is to track and predict the motion of small cells defined by local reflectivity maxima. However, Crane has not yet published a procedure for predicting reflectivity contours given predicted cell locations.

Techniques for tracking and predicting other weather features of greatest concern for ATC (e.g. wind shears and turbulence) are in a more rudimentary state as the principal focus in the radar meteorological community has been on tracking/prediction of tornados and mesocyclones* by use of Doppler mean velocity signatures^[23]. Consequently, considerable research and development in this area may be necessary (the use of spectrum width as a turbulence indicator is discussed below).

The FAA effort in this area should be focussed on obtaining significant operational experience with real time use of these tracking and prediction algorithms so that the appropriate means of scan-to-scan correlation can be determined. This validation/refinement activity will need to be carried out on a variety of data from various geographical locations to determine if weather type dependent correlation algorithms must be utilized and to determine the extent to which bad radar data (e.g., clutter, aircraft returns, and obscuration) will cause unacceptable algorithm errors.

4. Feasibility of Turbulence Detection and Tracking Using Spectral Width

Given the current uncertainties regarding convective storm dynamics, direct radar detection of turbulence is much more desirable for an automated ATC weather system than inferring the presence of turbulence from overall storm structure. Lincoln Laboratory has been engaged in a study for the FAA of the utility of detecting turbulence using the spectrum width parameter^[9]. The preliminary results^[44] of this effort suggest that spectral width appears to offer a much better correlation with aircraft sensed turbulence than does reflectivity. However, the correlation has been less than perfect in a number of cases. Several mechanisms have been suggested for these differences:

*We view the Doppler product based detection of tornados and mesocyclones as being of less urgency for the ATC environment since these phenomena are generally associated with radar reflectivities that would be viewed as hazardous to aircraft.

- (a) coupling of wind shear into the spectrum width estimate so that the width no longer reflects homogenous turbulence, and
- (b) storm evolution during the time between radar sensing of the volume and aircraft penetration.

However, there are a number of other issues which also need to be addressed:

- (a) Aspect dependence of spectral width has not been investigated experimentally via multiple Doppler measurements due to lack of spectrum width estimation (or, recording) on most research Doppler weather radars
- (b) The probability of detection and false alarm for various levels of turbulence has not been quantified for operationally realistic events. For example, most coordinated aircraft--weather experiments to date have probed close to severe thunderstorm cells so that the probability of encountering strong turbulence on a single penetration was essentially unity. Consequently, from such experiments, it is quite difficult to estimate the false alarm probability if one takes the (operationally reasonable) viewpoint that each penetration is a single event*.
- (c) Since spectral width can be biased badly upward at low SNR or shear or when obscuration and/or clutter are present, reliable turbulence detection via spectral width may necessitate use of additional spectral features.

Analytical studies (to better delineate the proper event space for a statistical characterization) and experimental studies are required.

D. Weather Radar Information System Architecture

The NEXRAD data from a given sensor must be processed further at air traffic control centers to generate appropriate displays for the users. Additionally, the data from other NEXRAD radars must be netted (mosaiced) to create a composite picture. The principal system for accomplishing this netting/data distribution function is the Center Weather Processor undergoing development in a separate FAA program.

To date, the CWP program has focused principally on netting reflectivity data from the NWS WSR-57 and displaying the netted radar data along with other meteorological data (e.g., satellite data) at a CWSU work station. Lack of resources has thus far prevented the CWP program from considering how new features such as:

*defining each point along the flight path as a single event is probably unreasonable due to the time differences between radar measurement of the volume and aircraft presence.

- 1) volume scan data
- 2) Doppler products, and
- 3) terminal/airport surveillance products

would be incorporated in the CWP architecture.

This lack of work in the CWP area has made it difficult to specify precisely the products needed from NEXRAD by the FAA and/or to define additional FAA supplied processors which may be needed at a NEXRAD site to permit a cost effective NEXRAD/CWP interface. For example, if the standard NEXRAD products are found to not meet the FAA needs (e.g., due to obscuration and/or clutter), it might be necessary to transmit raw NEXRAD products to the CWP where the requisite processing could take place. Accomplishing such base product processing for all the NEXRAD radars in an FAA region would probably increase the CWP processor requirements by over an order of magnitude from that currently contemplated.

Thus, it is essential that critical uncertainties related to the NEXRAD/CWP interface be addressed at this time. Specific issues which should be addressed include:

- 1) definition of the proposed hazardous aviation weather contour maps product and evaluation of the product with respect to reliability and impact on air space utilization;
- 2) computation and sensor scanning approaches for the generation of three dimensional (x,y,z) reflectivity and Doppler weather products;
- 3) the partitioning of data processing functions (e.g., clutter rejection, obscuration elimination and/or flagging, and higher level product computation) between the CWP and NEXRAD. This partitioning must take into account site dependency and regional weather factors discussed below;
- 4) definition of an automated short-term prediction capability for significant hazardous weather features of concern to aviation (to determine where such predictions should be generated);
- 5) evaluation of automated vs. manual (e.g., annotated) products for controller displays;
- 6) resolution of time delay problems with routing NEXRAD data through the CWP and then to TRACONS. A related task is the development of a DARC-like capability for display of NEXRAD data at a nearby TRACON if the CWP fails;

- 7) consideration of the coordinated use of available radar sensors (e.g., ASR-9) which have potentially complementary characteristics to get around some of the terminal/airport volume coverage and data rate dilemmas, and
- 8) utility of dual Doppler techniques at the CWP using data from adjacent NEXRAD to yield improved turbulence, LLWS and/or hail detection.

E. Experimental Assessment of Key Issues

The preceding sections have identified a number of issues which require experimental measurements. In this section, we briefly describe how a number of these could be addressed using existing S-band weather radars and by a transportable system.

1. Existing Weather Radars

The discussion in chapter II and sections A through C of this chapter have identified a number of difficulties that could be encountered by a base-line NEXRAD radar in attempting to meet FAA needs. It will be possible to study some of these problems experimentally using existing pencil beam S-band weather radars. Table 3.5 summarizes the principal desired characteristics for such a radar.

Table 3.6 summarizes the tasks which might be carried out using such radars. Below, we comment briefly on each of the topics:

(a) Clutter Rejection Techniques

A primary concern is that the NEXRAD base-line design, because of its use of a batched PRF, will not afford adequate clutter cancellation capability in areas with strong urban clutter. If the NEXRAD sites to provide airport service are located at the airports (as suggested in Appendix C), many of these sites will experience significant urban clutter. It is essential that various radar design features and clutter filtering strategies be evaluated on actual radar data. It would also be desirable to record raw (I, Q) time series data so that comparative studies can be carried out.

The system hardware should be compatible with a 50 dB clutter rejection capability. This will necessitate at least 10 bit A/D converters and an integrated instability residue power at least 50 dB down from the DC signal.

It is important to measure pertinent clutter statistics such as cumulative distribution versus range and elevation angle, correlation functions as a function of amplitude, spectral characteristics (e.g., mean velocity and spectrum width), etc., since such information will be of considerable utility to the NEXRAD contractors in their system design optimization.

TABLE 3.5
 DESIRED RADAR CHARACTERISTICS FOR
 NEAR TERM STUDIES

Antenna

Beam Shape	Pencil beam
Aperture	>18 feet
Gain	>40 dB
Sidelobe Levels	-26 dB minimum
Beamwidth	<1.5° one-way
Polarization	linear
Maximum rotation rate	6 r.p.m. (both axes)

Transmitter

Source	klystron preferred
Frequency	S-band
Peak Power	min 500kw
Pulse Width	1-3 μ s
P.R.F.	Variable (1200 Hz max.)

Receiver

Pre-selector	tunable
RF amplifier	solid state referred
Noise figure	<6 dB
STALO	crystal controlled
COHO	30 MHz crystal
Bandwidth	>500 kHz
STC	yes
STC curve	Programmable
M.D.S.	<-100 dBm

Digital Signal Processor

A/D Converters	12 bits I; 12 bits Q desired, 10 bits min.
Range sample spacing	1/16, 1/8, 1/4, 1/2 n.m.
Number of range gates processed	>250
Algorithm	pulse-pair processing
Processor output	0th, 1st, 2nd moments or I, v, σ_v

TABLE 3.6

TASKS ASSOCIATED WITH EXPERIMENTAL ASSESSMENT OF NEXRAD
PERFORMANCE USING EXISTING S-BAND PENCIL BEAM RADARS

CLUTTER MITIGATION STUDY

1. Site Survey: Statistical characteristics of clutter power as a function of elevation angle, range and scan rate
2. Performance of clutter rejection techniques against urban area clutter
 - a. Block mean level subtraction
 - b. "Continuous" IIR or, block IIR with filter initialization
 - c. 40 Point FIR

RANGE DEALIASING AND OBSCURATION--DUAL COHERENT INTERVAL SYSTEM STUDY

3. Obscuration Statistics: Empirical distribution of multiple trip obscuration--computed from low PRF reflectivity data.
4. Performance of Automated Range - Doppler Dealiasing Techniques: Operation with 3-moment processing/recording in two range intervals.

DAA/PREDICTION

5. Performance of Coherent I, v, σ_v Estimators: Analysis of storm time series data off-line. Experimentation with coherent estimation algorithms.

TURBULENCE DETECTION

6. Correlation of aircraft turbulence with radar measured σ_v and/or shear at various ranges.
7. Behavior of turbulent features: lifetimes, scale of evolution, spatial coherence, and relationship to reflectivity features.

TERMINAL AREA COVERAGE

8. Comparison of standoff detection performance with aircraft or tower measured hazards when operating at low altitude at 5-50 km from NEXRAD sensor.
9. Measurement of clear air reflectivity at times of low level wind shear.

OPERATIONAL UTILIZATION OF HAZARDOUS WEATHER PRODUCTS FROM RADAR

10. Real time evaluation at an ARTCC
11. Real time evaluation at an ARTS

(b) Range Dealiasing and Obscuration

A companion problem when operating a batch system is that of correctly range dealiasing Doppler measurements in the presence of ground clutter and out-of-trip weather interference. It is essential that the automated dealiasing algorithms for use with the JDOP batch mode and the two frequency approach be implemented and evaluated on a wide variety of weather data. In particular, the cases of widespread storm systems and fronts which coincide with a radar radial should be considered.

The dual coherent interval system concept discussed in the previous section should offer significant improvement over a batch system in two ways: An increase of 7-10 dB in overall system sensitivity for Doppler measurements, and automatic, continuous Doppler coverage at all ranges to 250 km. This system offers some advantages for implementation of an efficient IIR (or, FIR) clutter filter as well. These issues should be explored, and performance data acquired for comparison with theoretical analyses.

(c) Turbulence Detection

Work should continue to determine the utility of spectrum width and/or shear measurements as an indicator of hazardous turbulence in precipitation. Refinements such as shear removal correlation in the vertical dimension and tracking/prediction of σ_v (to reduce the effects of storm dynamics in correlating old weather to current a/c position) should be used. Also, the flight paths should be planned to provide better probing of the storm periphery since performance in this region will have the greatest impact* on detection and false alarm statistics.

The aspect dependence of the spectral width parameter can be investigated by joint observations between the pairs of S-band radars. This should be particularly useful data since dedicated** joint S-band radar spectral width measurements have (to our knowledge) not been carried out previously.

*Most of the storm penetrations to date have passed close to intense cells, in which case the probability of encountering moderate to severe turbulence along the path was essentially unity. Consequently, there is virtually no data to use in computing false alarm statistics for turbulence detection.

**Dual S-band Doppler radar studies have been carried out by NSSL. However, our analysis of their data has found that one of the NSSL radars may have been saturated during the data recording. This saturation seriously corrupts the spectrum width data, but does not significantly effect the mean Doppler data which was the principal interest to the NSSL investigators.

It is also necessary to learn more about the statistical properties of radar sensed turbulent cells; their time scale of evolution, their degree of spatial coherence, and their relationship to reflectivity features within storms. Meteorologists should participate in this analysis. This work will aid the FAA in determining the feasibility of detecting and tracking such features in an enroute environment. Conclusions should be drawn concerning the minimum update rate and resolution requirements necessary to provide this type of weather product for the weather in various regions.

(d) Data Acquisition and Analysis (DAA)/Prediction

The editing of bad data, contouring, and correlation of various scans which forms the bulk of the DAA process is a prelude to higher order product generation and prediction. The principal focus of effort here should be to:

- (1) evaluate prediction algorithms with particular initial emphasis on high level reflectivity contour prediction
- (2) evaluate data editing procedures such as adaptive clutter filtering (based on DC clutter maps) and false alarm reduction using DC and non DC clutter maps together with intra-scan spatial correlation, and
- (3) develop a special purpose DAA processor based on the prediction algorithms and the site specific experience of data editing.

By having a special purpose DAA processor accomplishing much of the routine data editing, contouring and elemental feature extraction (e.g., reflectivity peaks), several important benefits can be obtained in an operational system:

- (1) the main processor will be able to utilize its flexibility on higher order product features as opposed to being computation bound by the DAA processing, and
- (2) the DAA process can be carried out at a remote site and the data sent over a relatively low data rate line to a common processing center. Similarly, if the higher order product processor should fail, the DAA processor output could furnish useful data (e.g., contours of reflectivity) over low data rate lines*

*By contrast, if the DAA and contouring are carried out in the higher order product computer, failure of that computer would mean that very high data rate lines would be needed to furnish the "raw" weather radar data to ATC centers.

The experience obtained with such a DAA processor should be very useful to the FAA in its integration of NEXRAD sensor data into the ATC system.

(e) Operational Utilization of Hazardous Data at an ARTCC

To provide early experience with the NEXRAD weather product/ATC controller interface, a concentrated effort should be made to generate a real time display of hazardous weather areas [e.g., heavy precipitation and (hopefully) turbulence] at an ARTCC. Past experience of NWS weather radar usage by air traffic controllers^[89] suggests that it is essential to present simultaneous displays of aircraft positions and hazardous weather regions on the same scope.

We envision the assessment of the operational utility of NEXRAD derived products as occurring in two phases. The first phase would be an interactive, data gathering program to obtain feedback from operational ATC personnel on the utility of various weather products, and generate a data base for CWP/NEXRAD interface studies. This would be accomplished by using representative radars, signal processors and weather product generators to furnish data to one or more ATC facilities as well as recording data for later analysis.

During the first phase, weather products would be supplied in real time both in the CWSU meteorologist work area and at an offline PVD display which was being observed by off duty controllers. The CWSU display would be in color (using formats developed by the FAATC CWSU work station development center) and have the capability of displaying the PVD display as well as CWSU meteorologist oriented data. The CWSU meteorologist would be able to compare the NEXRAD derived data with other meteorologist (and, NWS radar) data to assess the accuracy and reliability of the automated products as well as providing feedback as to how the products could better be adapted to the regional weather characteristics. Table 3.7 summarizes the CWSU display usage.

Examples of issues in which the CWSU meteorologist feedback would be particularly useful in the first phase include:

- 1) resolution in x-y plane as a function of range;
- 2) generation and display of the three dimensional reflectivity and velocity information;
- 3) utility of the short term prediction algorithms;
- 4) performance of data scrubbing and range dealiasing algorithms, and
- 5) information loss with various weather product contouring algorithms.

TABLE 3.7

NEAR TERM COLOR DISPLAY USAGE AT ARTCC CWSU

1. Evaluate/Interpret PVD Display
2. Evaluate Non WSR Products
 - Composite Reflectivity/Cappi
 - Echo Tops
 - Contour Tracking/Prediction
 - Radial Velocity Products
 - Wind Fields
 - Shear
 - Turbulence
3. Validation of NEXRAD Products by Comparison With Other Weather Data Sources
 - WSR
 - Station Observations
 - Satellite

The recorded reflectivity and Doppler products could be used at the FAATC CWSU work station development facility to develop the capability for NEXRAD data display.

Although many potentially useful NEXRAD products (e.g., turbulence and low level wind shear detection) require significant R&D before users could provide meaningful comments, certain other principal products (especially, volume reflectivity) are sufficiently mature to solicit feedback from controllers at this time. The utility of such feedback from users at an early point in system development has been demonstrated in the successful Lincoln work on the MTD/ASR-9, DABS and TCAS programs. Additionally, the availability of weather data at the ARTCC will facilitate conducting experiments with a dedicated aircraft to validate some of the less mature NEXRAD products as well as obtaining pilot reports from aircraft near regions identified as having hazardous weather by the radar.

The suggested usage of the PVD display is summarized in table 3.8. The initial focus will be on volume reflectivity products since these probably will be the principal NEXRAD products for ATC controller real time display. The specific NEXRAD products might include composite reflectivity contours, radar echo tops information and short time (10-20 minute) prediction of reflectivity contours. The display formats would be based on MITRE METREK and FAATC work. NEXRAD/CWP issues to be initially addressed include:

1. degree of data smoothing (e.g., area filtering and/or convex polygons)
2. need for suppression of fixed and moving clutter
3. data rate requirements
4. utility of short term predictions

This off-line development during the first phase would permit a candidate NEXRAD radar to be interfaced to a prototype CWP processor in the second phase for full operational evaluation (including development of ATC procedures) by meteorologists and controllers. This second phase needs to be accomplished as soon as possible since problems which arise in controller procedure developments may necessitate NEXRAD radar processing and/or product changes.

(f) Terminal/Airport Coverage

Finally, studies should be carried out on the ability of a stand-off NEXRAD-like sensor to provide automated coverage of the terminal/airport airspaces by terminals located up to 40 km away. Chapter II and sections A and B of this chapter have highlighted some of the difficulties associated with providing the necessary weather products from a remote sensor sited and designed to provide surveillance of the en route airspace.

TABLE 3.8

INITIAL PVD DISPLAY USAGE AT ARTCC

Assess Utility of NEXRAD Reflectivity Products and Display Formats

Validation by Comparison With Other Weather Data Sources

Video or WFMU from ASR/ARSR

Pilot Reports

Data Scrubbing and Smoothing Issues

Tradeoff Display Simplicity Versus Cell Detection

Clutter Filtering and Mapping Capability

Interaction with Meteorologist in Product Usage

Control of Dedicated Aircraft for Turbulence and LLWS Experiments

Experiments should be performed in which the radar is scan scheduled to provide nominal NEXRAD enroute coverage, while simultaneously attempting to provide low altitude coverage of the approach-ways to local airports. Repeated approaches could be executed to the airport runways by an aircraft as storms move through the area. The radar products would be correlated with the LLWS, precipitation, hail, and turbulence actually encountered. If direct Doppler radar observation fails to provide detection of certain hazards such as gust fronts, processing strategies will be pursued to determine whether the presence of these hazards can be correctly inferred from other radar measurements of storm structure and knowledge of storm dynamics.

To provide additional routine data on LLWS which precedes precipitation, it would be very desirable to instrument a local high tower (e.g., TV tower) to measure and record wind speed, direction, and C_n^2 at altitudes (e.g., > 100m) where these phenomena are most pronounced. The phenomena measured at this tower would be correlated with radar data to provide quantitative assessment of LLWS detection performance (e.g., probability of detection and false alarm) from standoff ranges.

If an existing radar is in an urban area, it is anticipated that problems will arise due to blockage and obstruction effects of buildings. Such difficulties are considered to be representative of large urban airports. Engineering solutions which overcome these difficulties are expected to be broadly applicable.

(g) Operational Utilization of Hazardous Weather at a TRACON

The terminal coverage experiments outlined above would provide the experience base to carry out two phase investigation of NEXRAD weather data utilization at a TRACON facility similar to that outlined above for the ARTCC. Most of the ARTCC usage issues discussed above are germane for the terminal area. However, several additional issues will arise in the terminal area:

- a) algorithms for the automatic detection and tracking of LLWS must be validated in a wide variety of conditions;
- b) data scrubbing will become much more significant since the weather hazards have a much lower reflectivity and must be observed in the presence of strong ground clutter and/or sidelobe contamination;
- c) the accuracies of short term (10-20 minute) weather hazard extrapolation need to be much better as aircraft and controllers will be making much more rapid decisions on flight paths, and
- d) meteorologist support will not be as readily available as is the case of the ARTCC.

Since the terminal surveillance mission will place much more stringent demands on the radar processing, it is essential that an interactive data gathering program to obtain feedback from the users commence as soon as possible. Since the utility of NEXRAD data in terminal operations will be significantly effected by the local weather pattern - local ATC procedure interaction, measurements at a number of different terminals will be required to develop a standard terminal surveillance system.

2. Transportable Testbed Facility

A significant number of issues can be addressed with existing radars. However, there are important deficiencies with these sites which should be noted:

- (a) several important geographical areas will not be considered.
- (b) the clutter environment and visibility from existing sites may not be typical of the bulk of NEXRAD sites that will be used by the FAA, and
- (c) no data will be available from an airport location to validate terminal area performance.

It is well known that storm dynamics differ significantly across the United States. As it stands now, a goodly amount of Doppler weather data from JDOP-like radars will be available in the next 2-3 years for New England, the mid-west and high plains areas. However, there is currently a paucity of data from the southeast (e.g., Atlanta and Florida) and deep south (e.g., New Orleans) as well as from the northwest. The lack of southern data is viewed as particularly significant due to the common occurrence of convective activity in the spring, summer, and fall.

The Lincoln experience with ASR^[50], and ATCRBS radars^[61, 75, 78, 79], as well as the Microwave Landing System^[76, 77, 80] has clearly shown that measurements at a variety of representative sites are essential for characterizing the interference (e.g., clutter and shadowing) environment. Such an interference characterization is critical if meaningful procurement specifications are to be developed. The lack of data from airport environments is particularly of concern.

As a consequence of the above considerations, we have concluded that it is essential that there be a transportable experimental weather radar system to be used to validate concepts and algorithms, and test and evaluate weather

radar system products for tactical application* at a variety of representative sites. The technical requirements for this system should be based on the stated FAA air traffic control weather data requirements and be compatible with NEXRAD Joint Operational Requirements. If necessary, it should provide for a reconfiguration capability to meet either the enroute or the terminal requirements independently. The system parameters will be adaptable to various environmental conditions.

The transportable testbed facility should be designed and fabricated so that it can be readily moved from site to site to investigate geographical sensitivity and site dependence, particularly with respect to the FAA terminal area requirements associated with the NEXRAD program that are not addressed by other test facilities. We suggest conducting the test and evaluation (including validation of hazard correlations) at a minimum of three sites (e.g., semi-tropical, central U.S., and a high traffic density coastal site).

At each site, this system would be utilized to demonstrate that the radar data can be processed in a meaningful form within the update rate required by FAA. Particular attention should be placed on:

- (1) demonstrating that the methods used to minimize data contamination problems in both the en route and terminal areas will work under a variety of environmental conditions
- (2) evaluation of radar capability to adjust its parameters either automatically and/or by fixed software changes to adapt to different weather and air traffic control environments, and
- (3) assessment of the operational utility of various real time weather products for tactical use by controllers and local CWSU meteorologists.

The test bed would serve as a vehicle for developing and evaluating the mitigation of advanced Doppler weather radar products into the automated air traffic control system. This work would be in advance of the availability of NEXRAD data and hence provide the experience needed for key NEXRAD and Center Weather Processor (CWP) hardware decisions. The test bed would also support the investigation of issues related to the choice of weather products to be displayed for controllers, the update rate, extrapolation/prediction of features and, the incorporation of other data such as that from lightning and low level wind shear detectors.

*We anticipate that meteorologist oriented displays will be used at the Center Weather Service Unit to convey the full repertoire of NEXRAD data for use on a strategic basis. Validation of such products should be largely accomplished in the NEXRAD testbed work^[60].

The variety of data available from the weather radar and of meteorological regimes implies that there will be situation and site dependent algorithms for the processing and display of weather radar products. The display function should be interactive to allow the controller to select items of interest (e.g., extrapolation/prediction of storm tracks or cell tracks).

The end product of the field test program would be a technical data package giving the functional description of algorithms and process used to present controllers with timely weather radar data. An exhibit containing a description of the implementation in the test bed would also be prepared.

Figure 3.17 shows a block diagram of the transportable testbed. Full details on the testbed design cannot be specified at this time due to uncertainties in 1) the funding available, 2) evolution of the NEXRAD design, and 3) the need to resolve certain key issues with existing radars. Table 3.9 summarizes the current status of the principal hardware features. Those items which are indicated with the legend TBD could be specified 1983 based on the experience with existing radars if the currently planned research programs can be executed. The minimal automated weather products from this system would be:

- (a) current and predicted reflectivity contours
- (b) en route regions where turbulence may be present (based on a combination of spectrum width and higher order product features)
- (c) regions where excessive radial shears and/or turbulence are present on final approach paths (when adequate SNR occurs)

The extent to which desirable higher order features such as hail detection, mesocyclones, tornados, etc., are available will depend principally on progress in the NEXRAD software development program.

INTERIM TESTBED RADAR

114735-N

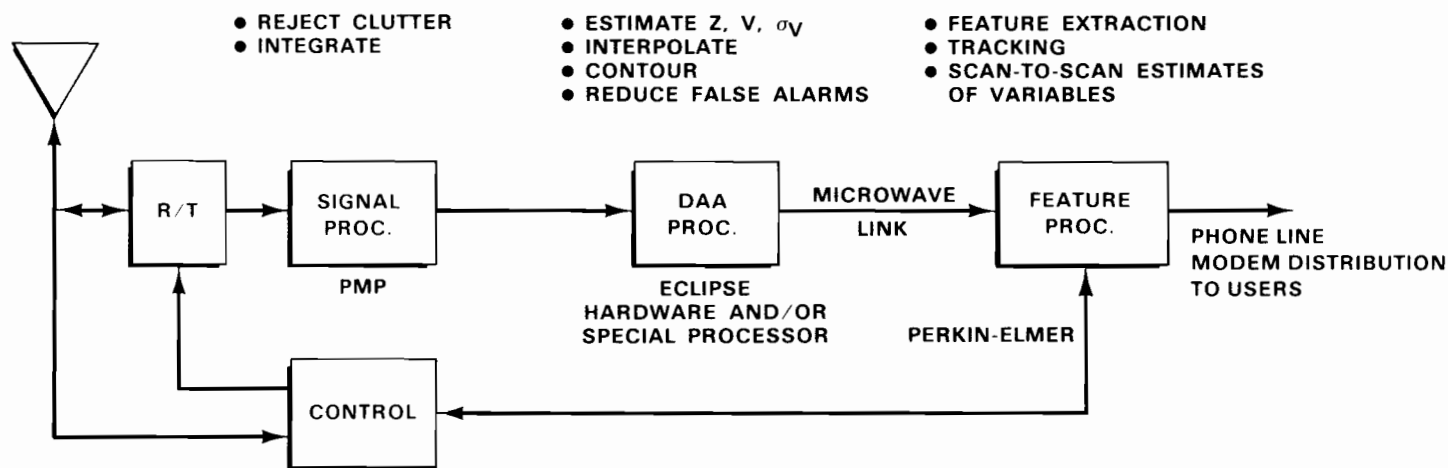

- REJECT CLUTTER
- INTEGRATE

- ESTIMATE Z, V, σ_V
- INTERPOLATE
- CONTOUR
- REDUCE FALSE ALARMS

- FEATURE EXTRACTION
- TRACKING
- SCAN-TO-SCAN ESTIMATES OF VARIABLES

OUTPUTS

- MULTI-LEVEL INTENSITY CONTOURS
- TRACKS — CENTROIDS OF VELOCITY SPREAD CELLS
- CENTROIDS OF HIGH-INTENSITY CELLS
- $z, x, y, \dot{z}, \dot{x}, \dot{y}$, CONFIDENCE/QUALITY
- POSITION REPORTS OF FEATURES
- DATA RECORDING FOR ANALYSIS AND REFINEMENT

Fig. 3.17. Transportable testbed block diagram.

TABLE 3.9
TRANSPORTABLE TESTBED EQUIPMENT FEATURES

Antenna

Aperture	TBD (18 to 26 feet)
Sidelobe levels	TBD (minimum -25 dB)
Polarization	linear-horizontal
Maximum rotation rate	TBD
Adaptive scan patterns	Yes

Transmitter

Source	TBD (klystron if orthogonal signals are used)
Frequency	S-band
Peak Power	TBD
PRF	Variable (1200 Hz max)
Signal waveform(s)	TBD

Receiver

Preselector, RF amplifier, Noise figure, STALO, COHO	Similar to M.I.T. radar
Bandwidth, MDS	TBD (depends on signal waveform)
STC	Programmable
AGC	TBD

Signal Processor

A/D converters	at least 10 bits
Spectral estimation	TBD
Clutter filtering	TBD
DCI	Yes

IV. CONCLUSIONS AND RECOMMENDATIONS

In this report we have reviewed the weather surveillance services acquired by the FAA, taking into account:

- a) Accident statistics for both commercial carrier and general aviation operations over the past decade,
- b) The current state-of-the-art in radar meteorology, and
- c) The weather measurement capability that would be provided by a joint-use network of JDOP-like NEXRAD sensors sited as suggested by Mitre (Reference 64).

In this chapter, we summarize the findings documented in this report, as well as the recommendations made in chapter III for further FAA investigations.

A. Essential/Achievable Capability with Joint-Use NEXRAD Network Alone

The FAA requirements for NEXRAD products do not make a clear distinction between those products to be used in the en route region as opposed to the terminal/airport regions. Based on the statistics of weather related accidents and the current radar meteorological capabilities of pulse Doppler radars, we have concluded that there are significant differences in the essential, achievable automated capability that can be provided in these two different regions.

For the terminal/airport regions, the primary concern is that accurate measurements of low level wind shear (LLWS) and turbulence be provided in both precipitating and non-precipitating regions of storms. In the en route airspace, measurement of turbulence hazards is desirable, but not nearly so crucial for reduction of fatal weather-related accidents.

Another distinguishing characteristic of the airport/terminal environment is the need for faster update rates since the aircraft have much less flexibility in their choice of flight path (especially when making precision approaches) and, weather phenomena of concern (e.g., downbursts) evolve fairly rapidly. The need for fast update rates will necessitate automatic detection and tracking of the hazards, which will in turn place particularly stringent requirements on the radar data quality.

The likelihood of accomplishing the above airport/terminal surveillance objectives with a NEXRAD network radar were shown to be low due to the constraints on scan rate, data rate and system siting which were discussed in section C of chapter II. Certain of these constraints could be reduced by fairly minor changes to the NEXRAD requirements such as:

- (i) reduced accuracy for weather parameters,
- (ii) increasing the maximum scan rate, and
- (iii) prioritizing certain products

However, system siting/coverage constraints may still prevent successful surveillance of many of the "top 40" airports.

For the en route airspace a system such as the joint-use NEXRAD network could perform reliable surveillance using radar reflectivity as the primary detection criterion. Doppler features would also be measured, but often with large estimate variances and not at the full range of the sensor. The system must be capable of automatic tracking of reflectivity cells. To the extent that it proves feasible to do so, the system should also track strong coherent Doppler features embedded in precipitation. Examples of this would be mesocyclones, tornadoes, and some types of shear phenomena. Coverage of high altitude portions of nearby terminal and airport airspaces would be automatic.

Reliable radar detection of clear air turbulence and wind shear in the identified en route region (e.g., above 6 kft altitude) is viewed as unrealistic due to the extremely low signal to noise ratios which will occur. Similarly, the identification of fine line phenomena at ranges greater than 60 km will be problematic due to the poor low altitude coverage as well as the degraded altitude resolution (>3000 ft. resolution cells).

Table 4.1 summarizes the services that the FAA can realistically expect to obtain from a joint-use network of NEXRAD radars.

B. Essential/Achievable Capability With Joint-Use Networking Augmented by FAA Special Use Radars

As a consequence of the above considerations, we have concluded that the use of an airport based radar specifically dedicated to airport/terminal service with the en route service being provided by the JDOP sensors with the suggested siting appears to offer the cost effective approach to providing the desired service in the en route and terminal/airport areas. Such a sensor would use netting of the surrounding NEXRAD sites to provide the full volume scan coverage (on a 5 minute update period), thus freeing the terminal radar to spend more time providing:

- 1) High resolution, low altitude surveillance coverage oriented specifically toward detection of hazardous phenomena such as gust fronts and microbursts.
- 2) Periodic monitoring of the approach and departure corridors using low scan rates and long dwell times to make reliable estimates of wind shear and turbulence (hopefully in clear air as well as precipitation), and

TABLE 4.1
ESSENTIAL/REALISTIC SERVICE FROM JOINT-USE NETWORKING OF
JDOP-LIKE NEXRAD PULSE DOPPLER RADARS

EN ROUTE SERVICE

- FULL VOLUME SCAN EVERY 5 MINUTES DOWN TO RADAR HORIZON
- AUTOMATIC DETECTION, CONTOURING AND TRACKING OF PRECIPITATION CELLS (5 MINUTE UPDATE RATE)
- DETECTION AND TRACKING OF SEVERE TORNADIC FEATURES USING DOPPLER CAPABILITY (5 MINUTE UPDATE RATE)
- POSSIBILITY FOR DETECTION AND TRACKING OF HAIL
- POSSIBILITY FOR DETECTION OF HAZARDOUS TURBULENCE OR SHEAR EMBEDDED IN PRECIPITATION

AIRPORT/TERMINAL SERVICE

- FULL VOLUME SCAN EVERY 5 MINUTES
- LIMITED COVERAGE OF CONE OF SILENCE BY ADJACENT NEXRAD AND/OR ASR-9 RADARS
- AUTOMATIC DETECTION, CONTOURING, AND TRACKING OF PRECIPITATION CELLS
- POSSIBILITY FOR DETECTION OF HAZARDOUS SHEAR FEATURES EMBEDDED IN PRECIPITATION
- LOW PROBABILITY OF SUCCESS IN DETECTION OF HAZARDOUS SHEAR FEATURES IN ABSENCE OF PRECIPITATION
- PREDICTION ACCURACY MAY BE POOR RELATIVE TO REQUIREMENTS FOR IMPROVED SAFETY AND EFFICIENCY OF RUNWAY UTILIZATION.

- 3) High update rate (30 second) tracking of both reflectivity and Doppler features after detection.

The features for a terminal/airport surveillance pencil beam pulse Doppler radar were not defined in detail; however, it is clear that the radar will require:

- 1) superior clutter rejection capability both in terms of clutter filtering and clutter mapping for rejection of the clutter residue,
- 2) a fast scan rate and processing capability for the high data rate updating,
- 3) wide dynamic range and good sensitivity (to observe LLWS and heavy precipitation), and
- 4) automatic avoidance of obscuration by higher order trip weather (needed for LLWS detection).

A key issue which arises is whether a NEXRAD radar with appropriate reprogramming for measurement sequencing could serve as the airport/terminal weather sensor. No unequivocal answer to this question was obtained in the present study.

The JDOP strawman design described in chapter II is deficient in several respects as a terminal/airport sensor:

- (a) the batch processing suggested will require FFT or FIR filters to accomplish the requisite clutter cancellation
- (b) the maximum scan rate of 3 rpm is not compatible with a fast update,
- (c) the range averaging used for reflectivity estimate would degrade interclutter visibility, and
- (d) no provision is made for automatic avoidance of obscuration

The NEXRAD contractors have been required to design to a more stringent requirement as far as clutter filtering and obscuration are concerned; however, the scan rate limitations will still apply and the obscuration avoidance techniques may not provide the needed capability.

What is needed here is an indepth study of the:

- 1) changes which would have to be made to the NEXRAD contractor designs to achieve the desired capability,
- 2) siting at representative "top 40" sites to determine coverage constraints and the number of sensors required, and
- 3) alternative sensor designs which may be more cost/effective than a modified NEXRAD network sensor.

C. Validation of NEXRAD Based Weather Surveillance System

The NEXRAD concept and many key products have been developed largely on the basis of experience with manually intensive techniques applied to a limited class of severe storms. Recent work on LLWS detection (e.g., the JAWS project experiments) have also relied heavily on manual intensive techniques applied by experienced radar meteorologists. This manual intensive analysis is incompatible with the FAA time urgency and manpower availability. Thus, it is essential that the concept of automatic hazard detection from NEXRAD data and netting/mosaicing/distribution to the users by the Center Weather Processor (CWP) be validated experimentally as soon as possible.

Specific areas of particular concern include:

- 1) resolution of uncertainties in key NEXRAD products and partitioning of the data processing functions between NEXRAD and the CWP.
- 2) assessment of the impact of site dependent and regional weather factors on the NEXRAD sensor design, NEXRAD/CWP processing and weather products. This will be particularly critical for the terminal/airport surveillance task.
- 3) impact of airport/terminal surveillance requirements on the CWP/NEXRAD architecture, and
- 4) coordinated use of the available weather sensors for improved weather surveillance (e.g., dual Doppler techniques with overlapping NEXRAD coverage to provide true wind velocities, use of the ASR-9 to detect rapidly evolving precipitation features).

It is recommended that the issues above be resolved by a two phase program. The first phase would be an interactive, data gathering program to obtain feedback from operational ATC personnel on the utility of the various weather products. This would be accomplished by using representative radars, signal processors and weather product generators with weather products being furnished in real time to one (or more) ATC

facilities*. Base data would be recorded for off-line analysis and algorithm refinement. Concurrent with this operationally oriented data gathering activity, smaller scale research oriented programs (e.g., JAWS project data reduction) should be carried out to develop additional weather detection capabilities.

It is not essential that the various signal processing functions in the first phase be carried out in "boxes" that match one-to-one with the current NEXRAD and CWP architecture; and, NEXRAD weather products of little or no interest to the FAA (e.g., vertical integrated water, 3-hour base product storage) need not be obtained. Consequently, it should be possible to configure an experimental representative weather radar information system at a far lower cost than that of the final NEXRAD/CWP system.

A significant amount of the phase one data gathering activity could be carried out by adding signal processing and display capability to existing FAA experimental sites (e.g., MIT and FAATC). However, the site/region dependency studies will require movement of a radar and signal processing system to appropriate locations. It is unlikely that existing "mobile" weather radars (e.g., CHILL or NOAA) could be made available for sufficiently long periods to accomplish the FAA program. Thus, it will probably be necessary to assemble a movable radar using existing FAA equipment to accomplish the required studies at a low cost and on a time schedule consistent with impacting the NEXRAD and CWP programs.

In the second phase, candidate NEXRAD radars would be interfaced to a prototype CWP processor to furnish weather products for operational evaluation by meteorologists and controllers. This work will need to be accomplished as early as possible since many difficult issues regarding controller procedures will need to be resolved. Also, operational procedure experiments may reveal additional requirements on the NEXRAD sensor.

*Real time data should be provided to ATC facilities to permit the comparison of the weather radar data with other available real time data (e.g., CWSU meteorological data and (solicited) pilot reports) as well as simplifying the logistics of obtaining knowledgeable operational users.

REFERENCES

1. K.A. Browning and R. Wexler, "The Determination of Kinematic Properties of a Wind Field Using Doppler Radar," J. Appl. Meteor. 7 (1968).
2. R.B. Chadwick, et al, "Design of a Wind Shear Detection Radar for Airports," IEEE Trans. on Geosci Electron GE-17, 4 (1979).
3. K.E. Coonley, "Antenna Approaches to Meet NEXRAD Update Rate," Draft Report, FAA SRDS (May 1980).
4. R.J. Doviak and C.T. Jobson, "Dual Doppler-Radar Observations of Clear Air Wind Perturbations in the Planetary Boundary Layer," J. Geophys. Res. 84, C2 (1979).
5. R.J. Doviak, et al, "Considerations for Pulse-Doppler Radar Observations of Severe Thunderstorms," J. Appl. Meteor. 17, 2 (1978).
6. G.P. Jain, "Initial NEXRAD Siting Analysis," Mitre Corp. Working Paper WP-79W00604, (October 1979).
7. S.I. Krich, "DABS Coverage," Project Report ATC-75, MIT/Lincoln Laboratory, (August 1977).
8. J.E. Kuhn, et al, "A Description of NEXRAD Costing Alternatives," Report No. DOT-TSC-FA-088-PM-80-28, (July 1980).
9. M. Labitt, "Coordinated Radar and Aircraft Observations of Turbulence," Project Report ATC-108, MIT/Lincoln Laboratory, (May 1981) FAA-RD-81-44.
10. P. MacCready, "Standardization of Gustiness Values from Aircraft," J. Appl. Meteor. (1964).
11. J. McCarthy, et al, "Instrumented Aircraft Verification of Clear-Air Radar Detection of Low-Level Wind Shear," 19th Conf. on Radar Meteor., Miami, Florida, April 15-18, 1980.
12. P. Rempfer, et al, "First-Cut NEXRAD Alternatives Analysis (Revision 1)," Report No. DOT-TSC-FA-088-PM-80-25, June 1980.
13. L. Rutledge, "Expanding Liability of Air Traffic Controllers for Air Crash Disasters," Alabama Lawyer, Vol. 37, p. 551-562, October 1976.

14. G.R. Smythe, "The Retrieval of Mesoscale Horizontal Winds Using a Single Doppler-Radar," 19th Conf. on Radar Meteor., Miami, Florida, April 15-18, 1980.
15. J.M. Speiser, "Dynamics of Airline Crash Litigation," J. Air Law, Vol. 43, p. 565-583, Winter 1977.
16. R.G. Strauch and W.B. Sweezy, "Wind Shear Detection with Pulse Doppler Radar," Report No. FAA-RD-80-26, January 1980.
17. D.S. Zrnich and R.T. Doviak, "Effective Antenna Pattern of Scanning Radars," IEEE Trans. on Aerospace and Electron Systems AES-12, 5 (1976).
18. D.S. Zrnich, "Estimation of Spectral Moments for Weather Echoes," IEEE Trans. Geosci. Electron. GE-17, 4 (1979).
19. D.S. Zrnich, "Spectrum Width Estimate for Weather Echoes," IEEE Trans. on Aerospace Electron. AES-15, 5 (1979).
20. "Air Traffic Control," FAA ATC Procedures Manual, 1 January 1980.
21. "Liability of the United States for Negligence of Air Traffic Controllers," in Federal Annotated Law Reporter, Vol. 46, p. 24 (West Publishing Co., 1978).
22. Private Communication with Mr. Michael J. Pangia, Assistant Director, Torts Branch Civil Division, U.S. Department of Justice.
23. Final Report on the Joint Doppler Operational Project (JDOP) 1976-1978. NOAA Technical Memorandum ERL NSSL-86, March 1979.
24. Submission of FAA Operational Weather Requirements to Art Hansen, JSPO, 14 December 1979.
25. NEXRAD Joint Operational Requirements, JSPO Working Document dated January 1981.
26. Aircraft Incident Report: Eastern Airlines N8139, Atlanta Hartsfield International Airport, Atlanta, Georgia, 22 August 1979 (NTSB-AAR-80-6).
27. Aircraft Accident Report: Southern Airways N1335U, New Hope, Georgia, 4 April 1977. (NTSB-AAR-78-3).
28. Aircraft Accident Report: Continental Airlines N88777, Stapleton International Airport, Denver, Colorado, 7 August 1975. (NTSB-AAR-76-14).

29. Aircraft Accident Report: Eastern Airlines N8845E, JFK International Airport, Jamaica, New York, 24 June 1975.
30. Aircraft Accident Report: Ozark Airlines N4215, near Lambert-St. Louis International Airport, St. Louis, Missouri, 23 July 1973.
31. NTSB ATC Group Chairman's Preliminary Factual Report of Aircraft Accident DCA-80-A019. (Air Wisconsin SW-4, near Valley, Nebraska, 12 June 1980)
32. Annual Review of Aircraft Accident Data, U.S. Air Carrier Operations (1978). NTSB Report No. NTSB-ARC-80-1.
33. Annual Review of Aircraft Accident Data, U.S. Air Carrier Operations (1977). NTSB Report No. NTSB-ARC-78-2.
34. Annual Review of Aircraft Accident Data, U.S. Air Carrier Operations (1976). NTSB Report No. NTSB-ARC-78-1.
35. Briefs of Fatal Accidents Involving Weather as a Cause/Factor, U.S. General Aviation (1978). NTSB Report No. NTSB-AMM-80-5.
36. Briefs of Fatal Accidents Involving Weather as a Cause/Factor, U.S. General Aviation (1977). NTSB Report No. NTSB-AMM-78-16.
37. Briefs of Fatal Accidents Involving Weather as a Cause/Factor, U.S. General Aviation (1976). NTSB Report No. NTSB-AMM-78-5.
38. R. M. Hill and B. H. Metzger, "Results of Operations Rates Measurement under various weather conditions at LaGuardia," 6th. Conf. on Aerospace and Aeronautical MX (November 1974).
39. Annual Review of Aircraft Accident Data, U.S. General Aviation, Calendar Year 1978. NTSB Publication NTSB-ARG-80-1.
40. FAA Report on Airport Capacity: National Summary (Vol. I), OSEM, FAA (January 1974) FAA-EM-74-5, I.
41. Aviation Week and Space Technology, "Shortlines," 27 March 1976, p. 37.
42. F. Coons and E. Mandel, "The FAA Wind Shear Research and Development Program: A Status Report," 7th Conf. on Aerospace and Aeronautical Meteorology, November 1976.

43. R.C. Goff, "The Low-level Wind Shear Alert System (LLWSAS)," FAA Report No. FAA-RD-80-45, U.S. Department of Transportation, Washington, D.C., 1980.
44. M. Labitt, "Coordinated Radar and Aircraft Observation of Turbulence," Electro '81 Conference, 1981.
45. R. Crane, "Thunderstorm Turbulence Hazard Prediction," U.S. Dept. of the Interior Document P-2832-F, ERT Inc., March 1981.
46. J. Metcalf, "Airborne Weather Radar and Severe Weather Operation," 19th Conf. on Radar Meteor., Miami, Florida, 125-129, April 1980.
47. R. Doviak, D. Zrnic' and D. Sirmans, "Doppler Weather Radar," Proc. of IEEE, Vol. 67, No. 11, 1522-1553, Nov. 1979.
48. T.T. Fujita, "Downbursts and Microbursts--An Aviation Hazard," 19th Conf. on Radar Meteor., Miami Beach, Florida, Amer. Meteor. Soc., Boston, Mass., 637-644, April 1980.
49. J. McCarthy, et al, "An Airport Wind Shear Detection and Warning System Using Doppler Radar," 19th Conf. on Radar Meteor., Miami, Florida, 135-142, 1980.
50. D. Karp and J. Anderson, "Moving Target Detector (MTD II) Summary Report," Project Report ATC-95, MIT/Lincoln Laboratory, FAA-RD-81-77, 1981.
51. J.F. Clark, "The Evaluation of Airborne Weather Avoidance Radar Toward a Calibrated Remote Rain Gauge Using REACH," 19th Conf. on Radar Meteor., Miami, Florida, 169-175, April 1980.
52. R. Carbone, et al, "The Multiple Doppler Radar Workshop, November 1979," Bulletin Am. Meteor. Soc., Vol. 61, No. 10, 1169-1203, 1979.
53. E.E. Gossard, "Refractive Index Variance and its Height Distribution in Different Air Masses," Radio Sci., 12, 89-106, 1977.
54. R.J. Doviak and M.I. Berger, "Turbulence and Waves in the Optically Clear Planetary Boundary Layer Resolved by Dual-Doppler Radar," Radio Sci., 15, 297-317, 1980.
55. R.K. Crane, "Stratospheric Turbulence," Force Geophysics Laboratory., Report. No. AFGL TR 77-0207, Hanscom AFB, Mass., 1977.

56. R. Doviak, R. Rabin and A. Koscielny, "Prestorm Boundary Layer Observations with Doppler Radar," 20th Conf. on Radar Meteor., Boston, Mass., 546-553, 1981.
57. B.G. Laird "On Ambiguity Resolution by Random Phase Processing," 20th Conf. on Radar Meteor., Boston, Mass., Amer. Meteor. Soc., 327-331, Nov. 1981.
58. J. McCarthy, J. Wilson and T. Fujita, "The Joint Airport Weather Studies (JAWS)," 29th Conf. on Radar Meteor., Boston, Mass., Amer. Meteor. Soc., 762-768, Nov. 1981.
59. K.R. Hardy and I. Katz, "Probing the Clear Atmosphere with High Power, High Resolution Radars," Proc. IEEE, 57, 468-480, 1969.
60. NEXRAD JSPO "(Draft) Next Generation Weather Radar (NEXRAD) Research and Development Plan," Sept. 1981.
61. P.R. Drouilhet, "DABS: Functional Description," Lincoln Laboratory, MIT Project Report ATC -42 Rev. A, FAA-RD-80-41, April 1980.
62. P. Klass, "Technique Transmits Weather by VOR" Aviation Week and Space Tech., 89-93, Nov. 16, 1981.
63. W.R. Sousa "Transmittal of NEXRAD Operational Model (139 Sites)" letter to D. Hess of NEXRAD JSPO, May 1981.
64. MITRE, "Briefing to FAA: NEXRAD Siting Analysis" June 17, 1981.
65. D.V. Sarwate and M.B. Dursley, "Cross Correlation Properties of Pseudo-random and Related Sequences" Proc. of IEEE vol. 68, n. 5, 593-619.
66. N. Chakrabarti and M. Tomlinson, "Design of Sequences with Specified Autocorrelation and Cross Correlation" IEEE Trans. on comm., vol. COM-25.
67. U. Somaini, "Binary Sequences with Good Autocorrelation and Cross Correlation Properties" IEEE Trans. on Aerosp. and elect. Syst., vol. AES-11, No. 6, 1226-1231, Nov. 1975.
68. H. L. Groginsky, and K. Glover, "Weather Radar Canceler Design" Preprints, 19th Conf. on Radar Meteor., Am. Meteor. Soc., Boston, Mass., 192-201, 1980.
69. R. Passarelli, Jr. R. Romanik, G. Geotis and A. Siggia, "Ground Clutter Rejection in the Frequency Domain" Preprints, 20th Conf. on Radar Meteor., Am. Meteor. Soc., Boston, Mass., 295-300, 1981.

70. S. Hamidi and D. Zrnich, "Considerations for the Design of Ground Clutter Cancelers for Weather Radars Preprints, 20th Conf. on Radar Meteor., Am. Meteor. Soc., Boston, Mass., 319-326, 1981.
71. J. Anderson, "Evaluating Ground Clutter Filters for Weather Radars," Preprints, 20th Conf. on Radar Meteor., Am. Meteor. Soc., Boston, Mass., 314-318, 1981.
72. Sirmans, D., and J.T. Dooley, "Ground Clutter Statistics of a 10 cm Ground Based Radar," Preprints, 19th Conf. on Radar Meteor., Am. Meteor. Soc., Boston, Mass., 184-191, 1980.
73. Fletcher, H.R., and D. Burlarge, "An Initialization Technique for Improved MTI Performance in Phased Array Radars," Proc. of the IEEE, VOP, 60, 1551-1552, Dec. 1972.
74. D. Zrnich and S. Hamidi, "Considerations for the Design of Ground Clutter Cancelers for Weather Radar," NSSL Report DOT/FAA/RD-81/72, Feb. 1981.
75. W.I. Wells, "Verification of DABS Sensor Surveillance Performance (ATCRBS mode) at Typical ASR Sites Throughout CONUS" Lincoln Laboratory, M.I.T., Project Report ATC-79, Dec. 1977.
76. J. Evans, D. Sun, D. Shnidman, and S. Dolinar, "MLS Phase III Final Report, vol. 1: Overview and Propagation Model Validation/Refinement Studies," Lincoln Laboratory, M.I.T., Project Report ATC-88, FAA-RD-79-21, April 1979.
77. J. Capon, "Multipath Parameter Computations for the MLS Simulation Computer Program," Lincoln Laboratory, M.I.T., Project Report ATC-68, FAA-RD-76-55, Feb. 1976.
78. "Development of a Discrete Address Beacon System," Lincoln Laboratory, M.I.T., Quarterly Technical Summary, 1 April - 30 June 1976.
79. "Development of a Discrete Address Beacon System," Lincoln Laboratory, M.I.T., Quarterly Technical Summary, 1 Oct. - 31 Dec. 1976, 1977.
80. J. Evans, S. Dolinar, D. Shnidman and R. Burchsted, "MLS Multipath Studies, Phase 3 final report, volume III: "Development and Validation of Model for MLS Techniques," Lincoln Laboratory, M.I.T., Project Report ATC-88, Vol. III, FAA-RD-79-21, Feb. 1980.
81. T. Fujita, J. McCarthy and J. Wilson, "The Joint Airport Weather Studies (JAWS) Project," Proposal submitted to NSF, FAA, NOAA and NASA, Dec. 1980.

82. L. Hennington, "Reducing the Effects of Doppler Radar Ambiguities," Preprints, 19th Conf. on Radar Meteorology, Am. Meteor. Soc., Miami, FFL, pp. 216-218, 1980.
83. L. Cartledge, R.M. O'Donnell, "Description and Performance Evaluation of the Moving Target Detector," Report No. FAA-RD-76-190, Lincoln Laboratory, M.I.T., Project Report ATC-69, March 1977.
84. R.M. O'Donnell, L. Cartledge, "Comparison of the Performance of the Moving Target Detector and the Radar Video Digitizer," Report No. FAA-RD-76-191, Lincoln Laboratory, M.I.T., Project Report ATC-70, April 1977.
85. R. Crane, "Automatic Cell Detection and Tracking," IEEE Trans. on Geoscience Electronics, Vol. GE-17, pp. 250-262, Oct. 1979.
86. C.L. Bjerkaas and D.E. Forsyth, "Operational Test of a Three Dimensional Echo Tracking Program," Preprints, 19th Conf. on Radar Meteor., Boston, Mass., Amer. Meteor. Soc., 244-247, 1980.
87. C.L. Bjerkaas and D.E. Forsyth, "An Automated Real-Time Storm Analysis and Storm Tracking Program (WEATRAK)," AFGL-TR-80-0316, AFGL, Hanscom AFB, Mass., 115 pp., MPIS ADA 100236, 1980.
88. A.R. Bohne, "Estimation of Turbulent Severity in Precipitation Environments by Radar," Preprints, 20th Conf. on Radar Meteor., Boston, Mass., Nov. 1981.
89. D. Enders, "Interim Report - Evaluation of NWS Color Weather Radar and Comparison Study with Modified NAS (WFMU) Weather display," memo to Chief, Enroute Procedures Branch, AAT-330, July 1981.
90. A. Bohne, "Radar Detection of Turbulence in Thunderstorms," Air Force Geophysics Laboratory Report, AFGL-TR-81-0102, March 1981.
91. R. Crane, "Radar Analysis for Severe Weather Detection and Tracking," NSSL Report D-A579, by ERT, Inc., July 1982.

APPENDIX A

List of 76 FAA-designated airports which require terminal coverage.
First 40 sites also require airport coverage.

Source: Reference 24

FAA-Designated Terminal Airports

- | | |
|--------------------------------------|---|
| 1. Atlanta-Hartsfield International | 31. Milwaukee-General Mitchell Field |
| 2. Chicago-O'Hare International | 32. Louisville-Standiford Field |
| 3. Miami International | 33. Baltimore-Washington Intl. |
| 4. Dallas-Fort Worth Regional | 34. Tulsa International |
| 5. Denver-Stapleton International | 35. Columbus-Bolton Field |
| 6. Tampa International | 36. Dayton-James M. Cox Intl. |
| 7. St. Louis-Lambert International | 37. Birmingham Municipal Airport |
| 8. Washington, D.C. National | 38. Oklahoma City-Will Rogers
World Airport |
| 9. Houston Intercontinental | 39. Albuquerque International |
| 10. New York-John F. Kennedy | 40. Dulles International |
| 11. Pittsburgh-Greater Pitts. Intl. | 41. Greater Buffalo International |
| 12. New York-LaGuardia Airport | 42. San Juan-Puerto Rico Intl. |
| 13. Ft. Lauderdale-Hollywood Intl. | 43. Omaha-Eppley Airfield |
| 14. New Orleans International | 44. San Antonio International |
| 15. Orlando International | 45. Salt Lake International |
| 16. Kansas City International | 46. Shreveport Regional Airport |
| 17. Memphis International | 47. Little Rock-Adams Field |
| 18. Detroit Metropolitan Wayne Co. | 48. Las Vegas-McCarran International |
| 19. Philadelphia International | 49. Raleigh-Durham Airport |
| 20. Cleveland Hopkins International | 50. Knoxville-McGhee Tyson Airport |
| 21. Greater Cincinnati Intl. | 51. Des Moines Municipal Airport |
| 22. Boston Logan International | 52. Norfolk International |
| 23. Indianapolis International | 53. Greensboro-High Point-Winston
Salem Regional |
| 24. Phoenix Sky Harbor International | 54. Bradley International |
| 25. Minneapolis-St. Paul Intl. | 55. Roanoke Municipal Airport |
| 26. Jacksonville International | 56. Rochester-Monroe County Airport |
| 27. Newark International | 57. Wichita Mid-Continent Airport |
| 28. Nashville Metro Airport | 58. Tucson International |
| 29. Charlotte-Douglas Municipal | |
| 30. Palm Beach International | |

FAA-Designated Terminal Airports

59. Madison-Dane County Regional-Truax Field
60. El Paso International
61. Syracuse Hancock International
62. Albany County
63. Los Angeles International
64. San Francisco International
65. Seattle-Tacoma International
66. San Diego International-Lindbergh Field
67. Portland International
68. Honolulu International
69. Anchorage International
70. Sacramento Executive
71. San Jose Municipal
72. Metropolitan Oakland International
73. Spokane International
74. Ontario International
75. Burbank-Glendale-Pasadena Airport
76. Santa Ana-John Wayne Airport

APPENDIX B

Proximity of Designated Terminals to Preliminary NEXRAD Locations

Source: Reference 6

Compare Figure B.1 with Figure 2.11 to see the improvement after the second siting go-round. For the preliminary siting study, only 3 of the 40 sites designated for airport coverage, and 7 of the 33 terminal sites were listed as NEXRAD sites.

Proximity of Designated Terminals to Preliminary NEXRAD Sites

B-2

LOCATION	TERMINAL	MAP	PRIMARY AIRPORT		CLOSEST NEXRAD	NO.	LAT.	LONG.	(NM)
	SERVICE	NO.	LAT.	LONG.					
1. Atlanta Hartsfield	TCA I	109	3338	8426	Dobbins AFB	78	3355	8431	18
2. Chicago O'Hare	TCA I	111	4159	8754	Marseilles, Ill.	33	4122	8841	51
3. Miami International	TCA I	114	2548	8017	Miami, FL	36	2543	8017	5
4. Dallas-Ft. Worth	TCA I	112	3253	9702	Stephenville, TX	50	3213	9811	71
5. Denver-Stapleton	TCA II	118	3946	10453	Limon, Col.	30	3911	10342	67
6. Tampa International	TRSA	99	2758	8232	Tampa, FL	52	2742	8224	17
7. St. Louis Lambert	TCA II	128	3845	9022	St. Louis, MO	51	3848	9034	10
8. Washington National	TCA I	103	3851	7702	Patuxent River NAS	45	3817	7625	45
9. Houston Intercontin.	TCA II	120	2939	9517	Galveston, TX	21	2915	9448	33
10. New York - JFK	TCA I	115	4058	7347	New York, NY	43	4046	7359	12
11. Pittsburgh-Greater	TCA II	126	4030	8014	Pittsburgh	47	4032	8014	2
12. NY LaGuardia	(See NY JFK)		4047	7352	New York, NY	43	4046	7359	12
13. Ft. Lauderdale-Holly.	TRSA	39	2604	8009	Miami, FL	36	2543	8017	22
14. New Orleans	TCA II	124	3000	9015	Slidell, LA	49	3017	8946	30
15. Orlando	TRSA	71	2826	8119	Patrick AFB	91	2814	8036	40
16. Kansas City	TCA III	121	3918	9443	Kansas City	27	3906	9435	14
17. Memphis	TRSA	60	3503	8959	Memphis NAS	35	3521	8952	19
18. Detroit-Wayne	TCA II	119	4213	8321	Detroit	18	4214	8320	1
19. Philadelphia	TCA II	125	3952	7515	Atlantic City, NJ	5	3927	7435	41

Proximity of Designated Terminals to Preliminary NEXRAD Sites (Cont.)

	LOCATION	TERMINAL	MAP	PRIMARY AIRPORT		CLOSEST NEXRAD	NO.	LAT.	LONG.	(NM)
		SERVICE	NO.	LAT.	LONG.					
20.	Cleveland Hopkins	TCA II	117	4125	8151	Detroit	18	4214	8320	82
21.	Cincinnati-Greater	TRSA	31	3903	8440	Cincinnati	15	3904	8440	1
22.	Boston	TCA I	110	4222	7100	Pease AFB	92	4304	7049	43
23.	Indianapolis	TRSA	47	3944	8617	Grissom AFB	84	4039	8609	55
24.	Phoenix	TRSA	74	3326	11201	Williams AFB	73	3319	11139	20
25.	Minneapolis-St. Paul	TCA II	123	4453	9313	Minneapolis	38	4453	9313	0
26.	Jacksonville	TRSA	49	3029	8141	Waycross, GA	54	3115	8224	58
27.	Newark, NJ	(See NY JFK)		4042	7410	New York, NY	43	4046	7359	9
28.	Nashville Metro	TRSA	66	3608	8641	Nashville	41	3615	8634	9
29.	Charlotte-Douglas	TRSA	23	3513	8056	Pope AFB	33	3510	7901	92
30.	Palm Beach (West)	TRSA	104	2641	8006	Miami	36	2543	8017	59
31.	Milw. (Gen. Mitchell)	TRSA	62	4257	8754	Neenah, WI	42	4413	8833	72
32.	Louisville (Standiford)	TRSA	56	3811	8544	Cincinnati	15	3904	8440	74
33.	Baltimore-Wash. Intl.	TRSA	13	3911	7640	Harrisburg	63	4006	7712	61
34.	Tulsa International	TRSA	102	3612	9553	Oklahoma City	44	3524	9736	97
35.	Bolton Field	TRSA	30	3954	8308	Columbus	98	4000	8253	13
36.	James Cox Intl.	TRSA	32	3954	8413	Columbus	98	4000	8253	64
37.	Birmingham Municipal	TRSA	15	3334	8645	Centreville	12	3254	8715	47
38.	Will Rogers	TRSA	68	3524	9736	Oklahoma City	44	3524	9736	0

Proximity of Designated Terminals to Preliminary NEXRAD Sites (Cont.)

LOCATION	TERMINAL	MAP	PRIMARY AIRPORT		CLOSEST NEXRAD	NO.	LAT.	LONG.	(NM)
	SERVICE	NO.	LAT.	LONG.					
39. Albuquerque	TRSA	7	3503	10636	Kirtland AFB	71	3503	10636	0
40. Dulles International	TRSA								
41. Greater Buffalo	TRSA	18	4256	7844	Buffalo	10	4256	7844	0
42. San Juan-Puerto Rico									
43. Eppley Field	TRSA	69	4118	9554	Offutt	90	4107	9554	11
44. San Antonio	TRSA	86	2932	9828	Hondo	24	2921	9910	39
45. Salt Lake	TRSA	85	4047	11158	Hill AFB	85	4107	11158	20
46. Shreveport	TRSA	91	3227	9349	Longview	32	3221	9439	43
47. Adams Field	TRSA	55	3444	9214	Little Rock	31	3450	9215	6
48. McCarran Intl.	TCA II	122	3605	11509	Nellis AFB	89	3614	11502	11
49. Raleigh-Durham	TRSA	77	3552	7847	Pope AFB	93	3510	7901	44
50. McGhee Tyson	TRSA	50	3549	8400	Bristol	7	3626	8207	98
51. Des Moines	TRSA	34	4132	9339	Des Moines	17	4132	9339	0
52. Norfolk	TRSA	67	3654	7612	Langley AFB	88	3705	7621	13
53. Greensboro	TRSA	43	3606	7956	Pope AFB	93	3510	7901	71
54. Bradley									
55. Roanoke									
56. Rochester									
57. Mid-Continent	TRSA	105	3739	9726	Witchita	55	3739	9726	0

B-4

Proximity of Designated Terminals to Preliminary NEXRAD Sites (Cont.)

LOCATION	TERMINAL	MAP	PRIMARY AIRPORT		CLOSEST NEXRAD	NO.	LAT.	LONG.	(NM)
	SERVICE	NO.	LAT.	LONG.					
58. Tucson Intl.	TRSA	101	3207	11057	Davis-Monthan	77	3210	11053	5
59. Truax Field	TRSA	59	4308	8920	Neenah	42	4413	8833	74
60. El Paso Intl.	TRSA	35	3148	10623	Holloman AFB	86	3251	10606	65
61. Syracuse Intl.	TRSA	96	4307	7606	Binghamton	6	4212	7559	55
62. Albany	TRSA	6	4245	7348	Binghamton	6	4212	7559	102
63. Los Angeles Intl.	TRSA	113	3357	11825	L. A.	99	3403	11827	6
64. San Francisco	TCA I	116	3737	12222	Sacramento	48	3835	12129	72
65. Seattle	TCA II	127	4727	12218	Seattle	114	4727	12218	0
66. Lindbergh Field	TRSA	87	3244	11711	Mt. Laguna	109	3252	11625	40
67. Portland	TRSA	75	4535	13235	Portland	102	4536	12236	1
68. Honolulu									
69. Anchorage									
70. Sacramento	TRSA	83	3831	12130	Sacramento	48	3835	12129	4
71. San Jose	TRSA		3722	12155	Sacramento	48	3835	12129	76
72. Oakland Intl.	TRSA		3743	12213	Sacramento		3835	12129	63
73. Spokane	TRSA	93	4737	11732	Mica Peak	112	4734	11705	19
74. Ontario	TRSA	70	3403	11737	L. A.	99	3403	11827	43
75. Burbank	TRSA	19	3412	11821	L. A.	99	3403	11827	10
76. John Wayne	TRSA	89	3341	11752	L. A.	99	3403	11827	37

APPENDIX C

Proximity of Designated Terminal to Revised NEXRAD Sites

After the bulk analysis in this report was completed, a revised NEXRAD System Operational Model was suggested by the MITRE Corporation^[64]. Table C-1 shows the suggested locations, while tables C-2 and C-3 show the proximity of the 76 FAA designated airports (of Appendix A) to the revised siting. Figure 2.11 (in Chapter II) shows histograms of the maximum radar range required to cover the airport or terminal area for the revised siting. The coverage here is vastly improved over that for the preliminary siting. We see, however, that the terminal low altitude coverage requirement cannot be met in any case if line of sight visibility is required.

TABLE C-1
NEXRAD SITES (139)

CODE	NEXRAD SITE	STATE	LATITUDE/LONGITUDE
07.ABI	ABILENE	TX	322500N0994100W
07.ALB	ALBANY	NY AIRPORT	424443N0734805W
07.ESFL1	ALEXANDRIA	LA	311800N0922700W
07.APN	ALPENA	MI ALT	444500N0832900W
07.AMA	AMARILLO	TX	351400N1014200W
07.AQQ	APALACHICOLA	FL ALT	300000N0852000W
07.ATNI1	ASHTON	ID	443400N1112700W
07.ATL	ATLANTA	GA	333900N0842500W
07.AUS	AUSTIN	TX ALT	303800N0974500W
07.BJOW2	BATTLE MOUNN.	NV ALT	394000N1161500W
07.BIL	BILLINGS	MT ALT	471500N1071000W
07.BGM	BINGHAMTON	NY	421200N0755900W
07.BHM	BIRMINGHAM	AL ALT	332800N0865000W
08.BIS	BISHARK	ND	464600N1004500W
07.BYB	BLYTHEVILLE	AR MILITARY BASE	355800N0895700W
07.BOI	BOISE	ID	433400N1161300W
07.214	BOLTON	OH AIRPORT	395407N0830812W
07.BBNC1	BORON	CA ALT	364000N1173500W
07.BOS	BOSTON	MA	422200N0710200W
07.BRO	BROWNSVILLE	TX	255400N0972600W
07.NHZ	BRUNSWICK	ME ALT	433500N0705000W
07.BUP	BUFFALO	NY ALT	430147N0781209W
07.BTV	BURLINGTON	VT	442800N0730900W
07.CVS	CANNON	MI MILITARY BASE	342300N1031900W
07.COP	CAPE CANAVERAL	FL MILITARY BASE	282800N0803300W
07.HAT	CAPE HATTERAS	NC	351600N0753300W
07.CAR	CARIBOU	VA	465200N0680100W
07.CPR	CASPER	WY ALT	440000N1072500W
07.CDCU1	CEDAR CITY	UT	373600N1125200W
07.CHS	CHARLESTON	SC MILITARY BASE	325400N0800200W
07.CRY	CHARLESTON	WV	382300N0813700W
07.CLT	CHARLOTTE	NC	351300N0805600W
08.CYS	CHEYENNE	WY	410900N1044900W
07.OHD	CHICAGO	IL AIRPORT	415900N0875400W
07.CVG	CINCINNATI	OH	390400N0844000W
07.CLE	CLEVELAND	OH	412500N0815200W
07.CBN	COLUMBUS	MS MILITARY BASE	333900N0882700W
07.CDNO3	CONDON	OR	445800N1195700W
08.CRP	CORPUS CHRISTI	TX	274600N0973000W
07.FTW	DALLAS-FT. WORTH	TX AIRPORT	325348N0970201W
07.DAY	DAYTON	OH	395400N0841200W
07.DBT	DEL RIO	TX	292200N1005500W
07.DEN	DENVER WFO	CO	394500N1045200W
08.DSH	DES MOINES	IO	413200N0933900W
07.DTW	DETROIT	MI	421400N0832000W
07.DDC	DODGE CITY	KS	374600N0995800W
07.DOV	DOVER	DE MILITARY BASE	390800N0752800W
09.DLB	DULUTH	MN	465000N0921100W
07.VPS	EGLIN	FL MILITARY BASE	302900N0863200W
07.ELAT2	EL PASO	TX	314100N1061200W
07.FAL	FALLON	NV ALT	415000N1190000W
07.FHM5	FARMINGTON	NH	360500N1085200W
07.HOP	FT CAMPBELL	KY MILITARY BASE	364000N0873000W
07.FRI	FT RILEY	KS MILITARY BASE	390300N0964600W
07.GLS	GALVESTON	TX	291800N0944800W

TABLE C-1 (Continued)
NEXRAD SITES (139)

CODE	NEXRAD SITE	STATE		LATITUDE/LONGITUDE
7. GLD	GOODLAND	KS		392200N1014200W
7. RDR	GRAND FORKS	ND	MILITARY BASE	475800N0972400W
7. GJT	GRAND JNCN	CO		390700N1083200W
7. GRR	GRAND RAPIDS	MI		425300N0853100W
7. GRB	GREEN BAY	WI		442900N0880800W
7. GSO	GREENSBORO	NC	AIRPORT	360547N0795621W
7. GUS	GRISSOM	IN	MILITARY BASE	403900N0860900W
7. HNK	HANCOCK	NY	ALT	430900N0755800W
7. HMM	HOLLOMAN	NE	MILITARY BASE	325100N1060600W
7. IAH	HOUSTON	TX	AIRPORT	295858N0952045W
7. SVN	HUYTER	GA	MILITARY BASE	320100N0810900W
7. HOM	HURON	SD		442300N0981300W
7. IND	INDIANAPOLIS WSFO	IN		394400N0861600W
7. JAN	JACKSON	MS		321900N0900500W
7. JAX	JACKSONVILLE	FL	AIRPORT	302933N0814124W
7. JFK	JOHN F. KENNEDY	NY	AIRPORT JFK	403825N0734642W
7. MCI	KANSAS CITY	KS	AIRPORT	391757N0944304W
7. BIX	KESLER	MS	MILITARY BASE	302500N0885500W
7. EYW	KEY WEST	FL		243300N0814500W
8. ABQ	KIRTLAND	NM		350300N1063600W
7. TYS	KNOXVILLE	TN	AIRPORT	354900N0835900W
7. LCH	LAKE CHARLES	LA		300700N0931300W
7. STL	LAMBERT	MO	AIRPORT	384453N0902144W
7. LAS	LAS VEGAS	NV	AIRPORT	360500N1151000W
7. LHM	LITTLE ROCK	AR		345000N0921500W
7. SDF	LOISVILLE	KY		381100N0854400W
7. LGB	LONG BEACH	CA		334900N1180900W
7. HSN	MADISON ORIG	WI		430800N0892000W
7. GFA	MALMSTROM	MT		473100N1111000W
7. MQT	MARQUETTE	MI		463200N0873300W
7. XXX	MCGUIRE PHILADELPHIA	PA	NEW	395300N0751000W
7. MFR	MEDFORD	OR		420500N1224300W
7. MEM	MEMPHIS	TN		350300N0900000W
7. MIA	MIAMI	FL	ALT	255500N0801500W
7. MAF	MIDLAND	TX	ALT	303000N1033000W
7. MSP	MINNEAPOLIS	MN		445300N0931400W
7. HIB	MINOT	ND	MILITARY BASE	482500N1012100W
7. MSO	MISSOULA	MT		470200N1135900W
7. MKE	MITCHELL	WI	AIRPORT	425653N0875347W
7. VAD	MOODY	GA	MILITARY BASE	305800N0831200W
7. MYR	MYRTLE BEACH	SC	MILITARY BASE	334100N0785600W
7. BNA	NASHVILLE	TN		361500N0863400W
7. NEW	NEW ORLEANS	LA	AIRPORT	295934N0901523W
7. ORF	NORFOLK	VA	AIRPORT	365343N0761203W
8. LBF	NORTH PLATTE	NE		410800N1004100W
7. OKC	O. K. C	OK		352400N0973600W
7. OAK	OAKLAND	CA	AIRPORT	374300N1221300W
7. OHA	OHAMA	NE		412200N0960100W
7. MCO	ORLANDO	FL	AIRPORT	282554N0811929W
7. PBI	PALM BEACH	FL	AIRPORT	264058N0800545W
7. PIA	PEORIA	IL		404000N0894100W
7. COS	PETERSON	CO	ALT	383500N1045000W
7. PHX	PHOENIX	AZ	AIRPORT	332600N1120100W
7. PIT	PITTSBURGH	PA		403200N0801300W
8. PDY	PORTLAND	OR		453600N1223600W

TABLE C-1 (Continued)
 NEXRAD SITES (139)

CODE	NEXRAD SITE	STATE	LATITUDE/LONGITUDE
08.RAP	RAPID CITY	SD	440300N1030400W
07.REE	REESE	TX MILITARY BASE	333600N1020300W
07.ROA	ROANOKE	VA AIRPORT	371929N0795834W
07.WRB	ROBINS	GA MILITARY BASE	323800N0833600W
07.RSKW4	ROCK SPRINGS	WY	412600N1090700W
07.SAC	SACRAMENTO	CA	383500N1213000W
07.SLC	SALT LAKE CITY	UT	404600N1115700W
07.SAT	SAN ANTONIO	TX AIRPORT	293200N0982800W
07.SAN	SAN DIEGO	CA	324400N1171000W
07.SMX	SANTA MARIA WSO	CA	345400N1202700W
07.SEA	SEATTLE	WA AIRPORT	472700N1221800W
07.NEW	SEYMORE/POPE/DURHAM	NC NEW	352700N0783500W
07.SSC	SHAW	SC	335800N0802800W
04.NEW	SHEPRD/SILL/ALTS	TX NEW	342000N0985000W
07.SHV	SHREVEPORT	LA	322800N0934900W
07.SCIN5	SILVER CITY	NM	325900N1085800W
07.PSD	SIOUX FALLS	SD ALT	452000N0960000W
07.GEG	SPOKANE	WA	473800N1173200W
07.SGF	SPRINGFIELD	MO	371400N0932300W
07.NEC	SUITLAND	MD	385100N0765600W
07.TPA	TAMPA	FL AIRPORT	275826N0823158W
07.TAD	TRINIDAD	CO ALT	373300N1033100W
07.TOI	TROY	AL NEW	320000N0854200W
07.TUS	TUCSON	AZ AIRPORT	320706N1105635W
08.TUL	TULSA	OK AIRPORT	361155N0955316W
07.END	VANCE	OK MILITARY BASE	362000N0975400W
07.SZL	WHITEMAN	MO MILITARY BASE	384300N0933300W
08.ICT	WICHITA	KS	373906N0972551W
08.ISN	WILLISTON	ND	481100N1033800W

TABLE C-2
(HIGH PRIORITY AIRPORTS/TERMINALS)

CODE	AIRPORT/TERMINAL	STATE	NEXRAD SITE	DISTANCE (NMS)
214	BOLTON-COLUMBUS	OH	BOLTON	0.0
DFW	DALLAS-PT. WORTH	TX	DALLAS-PT. WORTH	0.0
IAH	INTERCONTINTL-HOUSTON	TX	HOUSTON	0.0
JAX	JACKSONVILLE	FL	JACKSONVILLE	0.0
JFK	JOHN F. KENNEDY	NY	JOHN F. KENNEDY	0.0
MCI	KANSAS CITY	KS	KANSAS CITY (RELOCATED)	0.0
STL	LAMBERT-ST. LOUIS	MO	LAMBERT	0.0
MKE	MITCHELL-MILWAUKEE	WS	MITCHELL	0.0
MSY	NEW ORLEANS	LA	NEW ORLEANS	0.0
MCO	ORLANDO	FL	ORLANDO	0.0
PBI	PALM BEACH	FL	PALM BEACH	0.0
TPA	TAMPA	FL	TAMPA (RELOCATED)	0.0
TUL	TULSA	OK	TULSA	0.0
CLT	DOUGLAS-CHARLOTTE	NC	CHARLOTTE	0.1
MSP	MINNEAPOLIS	MN	MINNEAPOLIS	0.1
ORD	O-HARE-CHICAGO	IL	CHICAGO	0.1
PHX	PHOENIX	AZ	PHOENIX	0.2
CLE	HOPKINS-CLEVELAND	OH	CLEVELAND	0.4
OKC	WILL ROGERS-OKC	OK	OKLAHOMA CITY	0.4
ABQ	ALBUQUERQUE	NM	KIRTLAND	0.6
IND	INDIANPOLIS	IN	INDIANPOLIS	0.6
ATL	HARTFIELD-ATLANTA	GA	ATLANTA	0.8
SDP	STANDIFORD-LOUISVILLE	KY	LOUISVILLE	0.9
BOS	LOGAN-BOSTON	MA	BOSTON	1.0
DAY	JAMES COI-DAYTON	OH	DAYTON	1.1
DTW	DETBOIT	MI	DETROIT	1.2
CVG	CINCINNATI	OH	CINCINNATI	1.3
MEM	MEMPHIS	TN	MEMPHIS (RELOCATED)	1.6
DEN	STAPLETON-DENVER	CO	DENVER	1.7
PIT	PITTSBURG	PA	PITTSBURG	2.7
PHL	PHILADELPHIA	PA	MCGUIRE/PHILY	4.2
DCA	NATIONAL-DC	VA	SUITLAND	5.5
BHM	BIRMINGHAM	AL	BIRMINGHAM	8.0
MIA	MIAMI	FL	MIAMI (RELOCATED)	8.7
BNA	WASHVILLE	TN	WASHVILLE	10.6
LGA	LAGUARDIA-NEW YORK	NY	JOHN F. KENNEDY	10.7
HWO	HOLLYWOOD-FT. LAUDERDALE	FL	MIAMI (RELOCATED)	12.2
EWR	NEWARK	NJ	JOHN F. KENNEDY	20.8
BWI	BALTIMORE	MD	SUITLAND	26.5
IAD	DULLES	VA	SUITLAND	28.7

DISTRIBUTION

<u>Distance (NM)</u>	<u>Frequency</u>
0	13
.1 to .5	6
.5+ to 1.0	5
1.0 to 2.0	5
2.0 to 5.0	2
5.0 to 10.0	3
10.0 to 20.0	3
20.0 to 30.0	3
TOTAL	40

TABLE C-3
(LOW PRIORITY AIRPORTS/TERMINALS)

CODE	AIRPORT/TERMINAL		NEXRAD SITE	DISTANCE (NMS)
TALB	ALBANY	NY	ALBANY	0.0
TDSH	DES MOINES	IO	DES MOINES	0.0
TGSO	WINSTON SALEM-GREENBORO	NC	GREENBORO	0.0
TORP	NORFOLK	VA	NORFOLK	0.0
TOAK	OAKLAND	CA	OAKLAND	0.0
TROA	ROANOKE	VA	ROANOKE	0.0
TSAT	SAN ANTONIO	TX	SAN ANTONIO	0.0
TTUS	TUCSON	AZ	TUCSON	0.0
TICT	MID CONTINENT-WICHITA	KS	WICHITA	0.0
TSEA	SEATTLE	WA	SEATTLE	0.1
TLAS	MCCABRAM-LAS VEGAS	NV	LAS VEGAS	0.2
TTYL	MCGHEE-KNOXVILLE	TN	KNOXVILLE	0.3
TMSM	TRUAX-MADISON	WS	MADISON	0.4
TPDY	PORTLAND	OR	PORTLAND	0.7
TGEG	SPOKANE	WA	SPOKANE	0.9
TSAN	LINDBERG-SAN DIEGO	CA	SAN DIEGO	1.1
TSLA	SALT LAKE CITY	UT	SALT LAKE CITY	1.2
TSHV	SHREVEPORT	LA	SHREVEPORT	1.4
TSMP	SACRAMENTO	CA	SACRAMENTO	4.9
TLIT	ADAMS-LITTLE ROCK	AR	LITTLE ROCK	7.1
THNK	HANCOCK-SYRACUSE	NY	HANCOCK	7.6
TOMA	EPPLEY-OMAHA	MB	OMAHA	7.8
TSPO	SAN FRANCISCO	CA	OAKLAND	10.9
TELP	EL PASO	TX	EL PASO	13.7
TLAI	LOS ANGELES	CA	LONG BEACH	17.0
TSNA	JOHN WAYNE	CA	LONG BEACH	18.9
TBUF	BUFFALO	NY	BUFFALO (RELOCATED)	27.4
TROC	MONROE/ROCHESTR	NY	BUFFALO (RELOCATED)	27.5
TBUR	BURBANK	CA	LONG BEACH	29.0
TSJC	SAN JOSE	CA	OAKLAND	29.2
TRDU	DURHAM-RALEIGH	NC	SEYMORE/POPE/DURHAM	30.9
TONT	ONTARIO	CA	LONG BEACH	35.3
TBDL	BRADLEY	CN	ALBANY	80.0

DISTRIBUTION

<u>Distance (NM)</u>	<u>Frequency</u>
0	9
.1 to .5	4
.5+ to 1.0	2
1.0 to 2.0	3
2.0 to 5.0	1
5.0 to 10.0	3
10.0 to 20.0	4
20.0 to 30.0	4
30.0 to 40.0	2
80.0	1
TOTAL	33

APPENDIX D

Description of Interim Testbed Using M.I.T. Radar

A number of the issues discussed in Chapter III can be studied using the M.I.T. Meteorology and Physical Oceanography department S-band weather radar. The radar is located atop the Green Building at M.I.T. at an altitude of 150 feet above ground level (as shown in fig. D-1). Figure D-2 shows the relationship of the radar to the Boston metropolitan area. Figures D-3 to D-5 show the view from the radar looking towards Logan International Airport, L.G. Hanscom Airport and 1200 ft. high towers located in Needham, MA.

A. Research Capability of M.I.T. Radar

Table D-1 summarizes the principal characteristics of the M.I.T. radar. Below, we comment briefly on how each of the topics discussed in Chapter III can be studied with this radar.

1. Clutter Rejection Techniques

The M.I.T. radar is ideally situated to investigate NEXRAD performance in a high clutter environment, and to test various design features and clutter filtering strategies that have been proposed. The current system utilizes a mean level subtraction clutter cancelling technique^[71]; however, it is possible to record raw (I, Q) time series data. Also, software has been developed to obtain pertinent clutter statistics such as cumulative distribution versus range and elevation angle, correlation function as a function of amplitude, spectral characteristics (e.g., mean velocity and width), etc. for this site.

2. Range Dealiasing and Obscuration

The dual coherent interval system concept discussed in Chapter III has been implemented on this radar and should offer a significant improvement over a batch system in two ways: An increase of 7-10 dB in overall system sensitivity for Doppler measurements, and automatic, continuous Doppler coverage at all ranges to 250 km. Also, New England often has wide spread storm systems so that stressful obscuration situations should arise fairly frequently.

113790-R

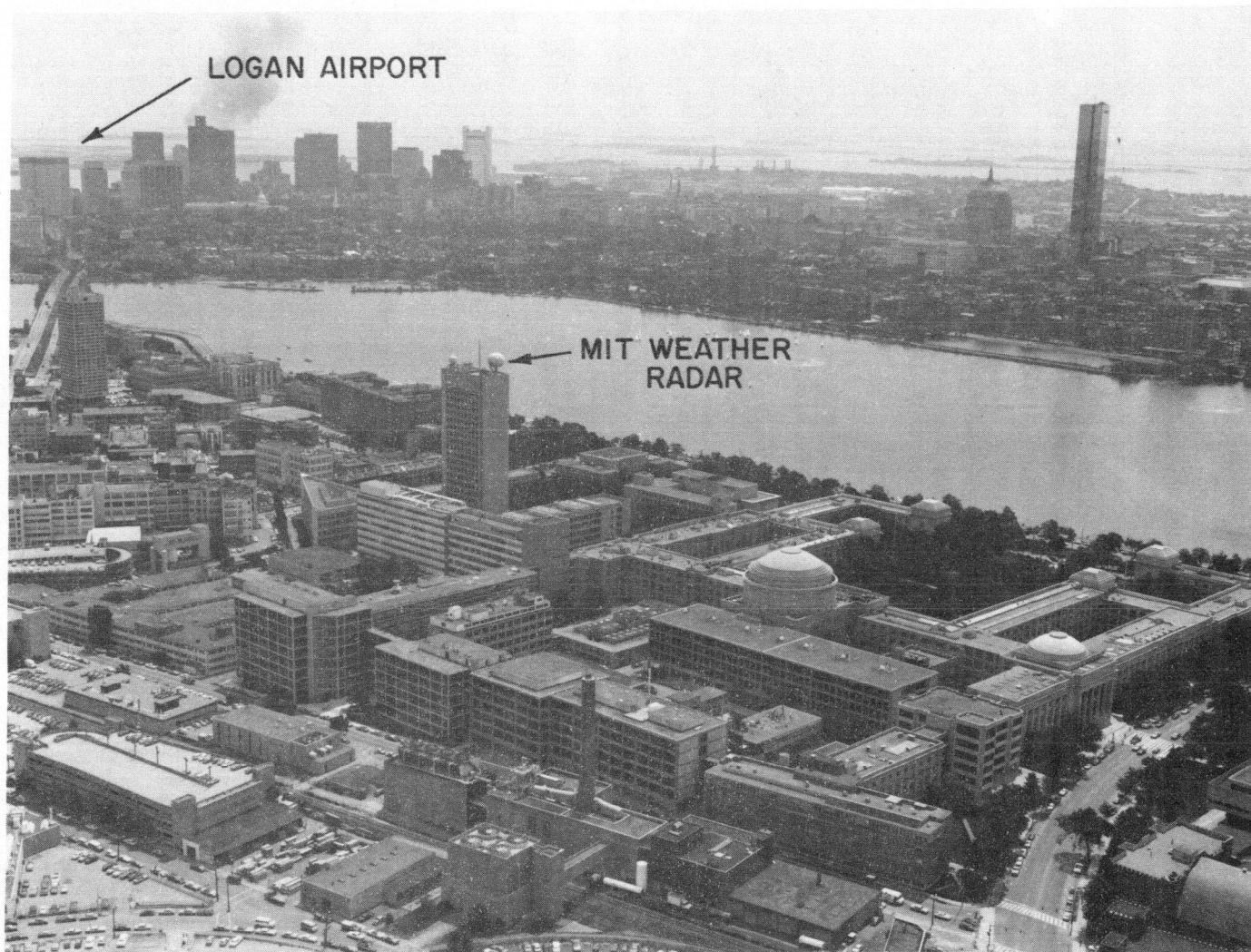

D-2

Fig. D-1. Interim testbed radar at M.I.T.

113791-R

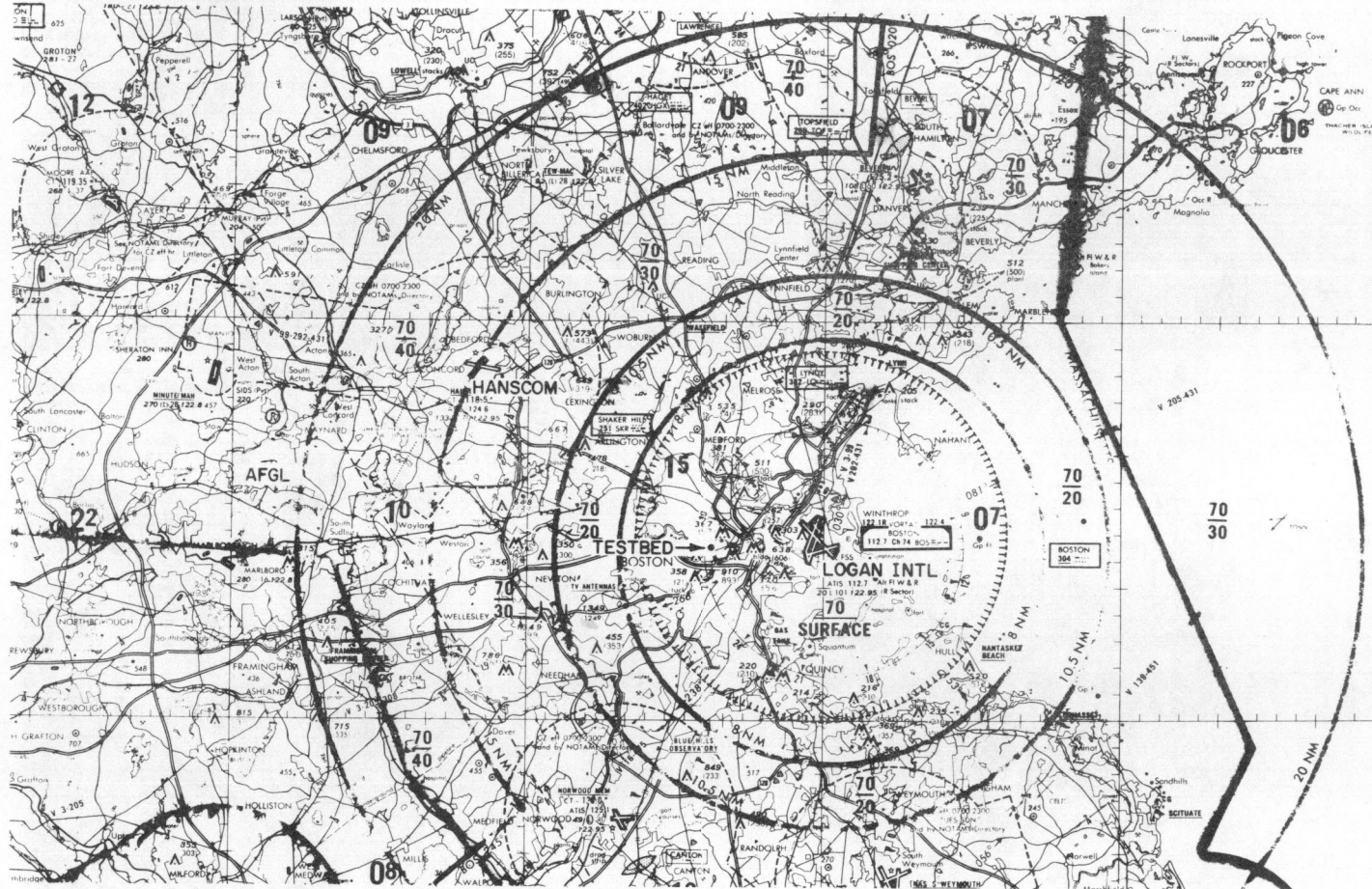

Fig. D-2. Relation of interim testbed to Boston area features.

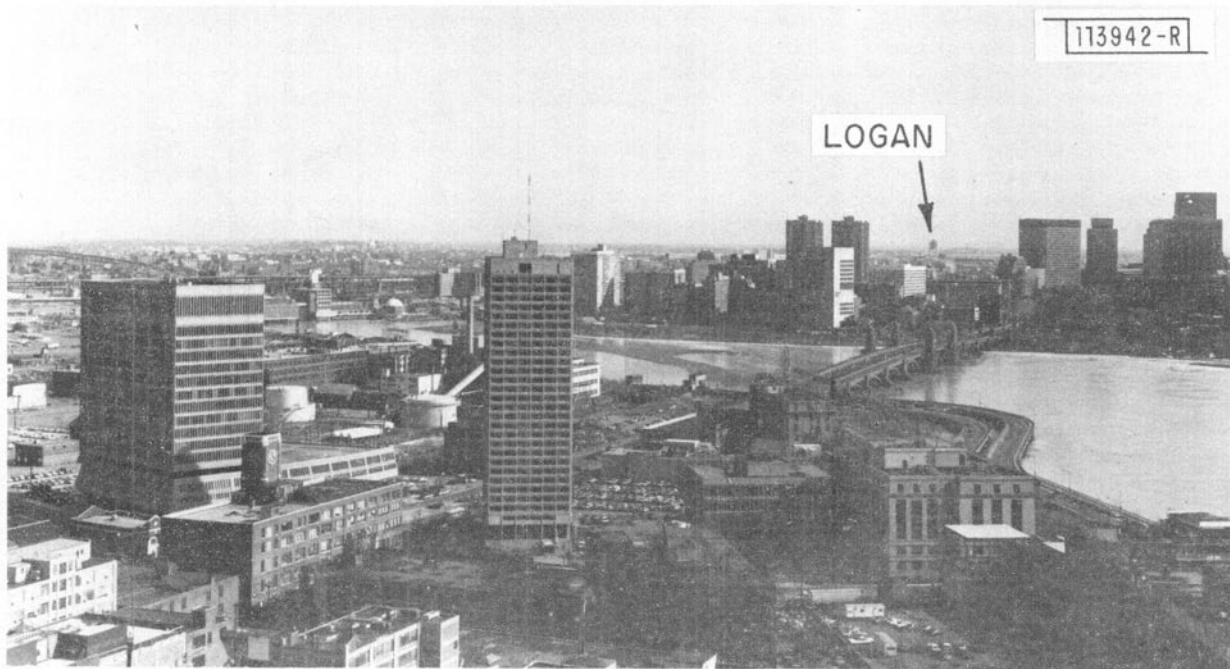

Fig. D-3. View from interim testbed toward Logan International Airport.



Fig. D-4. View from interim testbed toward L.G. Hanscom Airport.

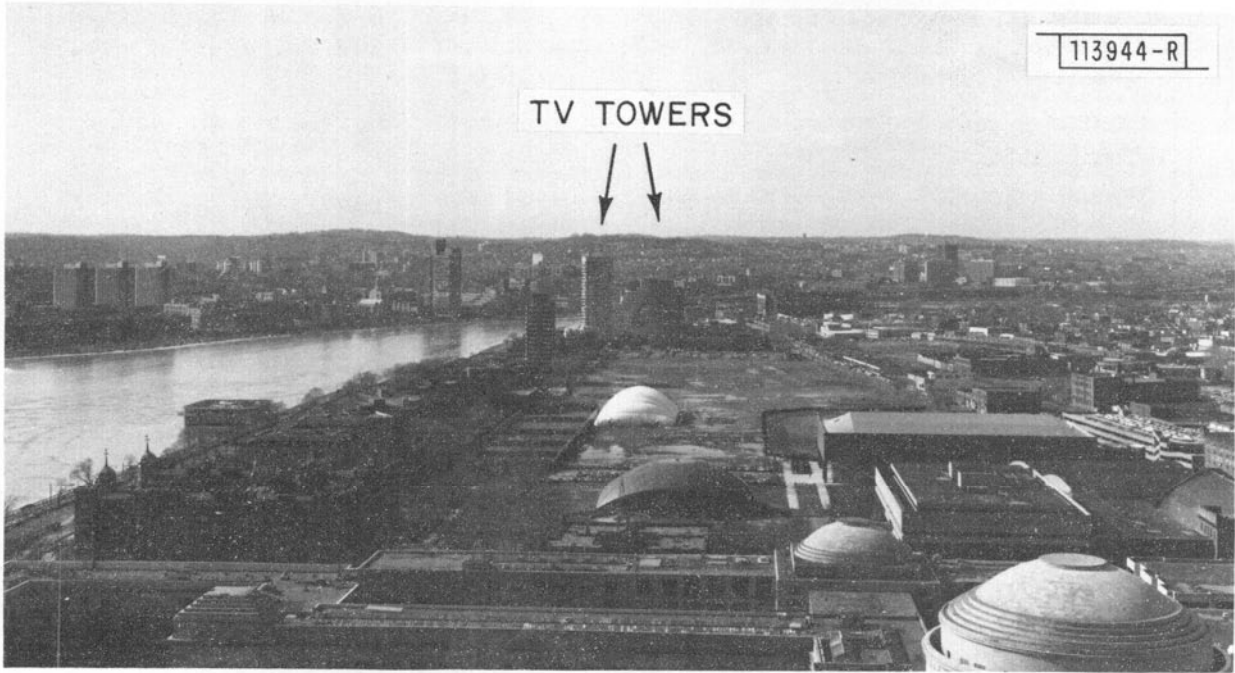

Fig. D-5. View from interim testbed toward Needham, MA TV towers.

TABLE D-1
MIT TESTBED RADAR CHARACTERISTICS

Antenna

Aperture	18 feet
Gain	42 dB
Sidelobe Levels	-26 dB minimum
Beamwidth	1.45° one-way
Polarization	horizontal
Maximum rotation rate	6 r.p.m. (both axes)
Height	312 ft. above m.s.l.

Transmitter

Source	VA87 klystron
Frequency	2705 MHz
Peak Power	1 MW
Pulse Width	1 microsecond
P.R.F.	Variable (1200 Hz max.)

Receiver

Pre-selector	tunable cavity
RF amplifier	solid state
Noise figure	4 dB
STALO	crystal controlled
COHO	30 MHz crystal
Bandwidth	1.1 MHz
STC	PIN diode at RF
STC curve	Programmable
M.D.S.	-103 dBm

Digital Signal Processor

A/D Converters	10 bits I; 10 bits Q
Range sample spacing	1/16, 1/8, 1/4, 1/2 n.m.
Number of range gates processed	288
Algorithm	pulse-pair processing
Processor output	0th, 1st, 2nd moments

3. Turbulence Detection

Simultaneous aircraft and weather radar observations similar to those discussed in ref. [44] can be carried out with the M.I.T. weather radar. Real time display of aircraft location data is obtained by having the Winthrop, MA ARSR beacon data sent to M.I.T. via a dedicated phone line with (selective) display of aircraft locations, landmarks, range rings, etc., managed by a minicomputer located at M.I.T.

The aspect dependence of the spectral width parameter can be investigated experimentally using the S-band radars at M.I.T. and AFGL. Since AFGL is also studying the utility of spectrum width data for the aircraft turbulence detection^[88], it may be possible to carry out coordinated aircraft dual Doppler experiments on turbulence detection.

4. Data Acquisition and Analysis

The large number of buildings and major highways visible from the M.I.T. radar site will provide ample opportunity to test various data editing procedures in a stressful environment. The likelihood of birds routinely causing false alarms is probably low due to the lack of nearby marshes and feeding areas; however, there will be a fairly large number of aircraft within view.

The initial DAA processing with the M.I.T. radar will be accomplished in a Perkin Elmer 3420 minicomputer, however, it is anticipated that a special purpose processor will be designed and utilized in the near future.

5. Operational Utilization of Hazardous Weather Data at Boston ARTCC

To provide a focus for the Lincoln effort and obtain early experience with the hazardous weather--ATC controller interface, we recommend the generation of a real time display of hazardous weather areas (e.g., heavy precipitation and (hopefully) turbulence) at the Boston ARTCC located in Nashua, N.H. The current plan is to present simultaneous displays of aircraft positions and hazardous weather regions on an offline position at this center as shown in figure D-6. The weather data would be obtained from the M.I.T. radar and the aircraft position data from DARC system with merging occurring at the PVD display level as indicated in figure D-7.

B. Deficiencies With M.I.T. Site

We have seen that a significant number of issues can be addressed with the S-band radar at M.I.T. However, there are important deficiencies with this site which should be noted:

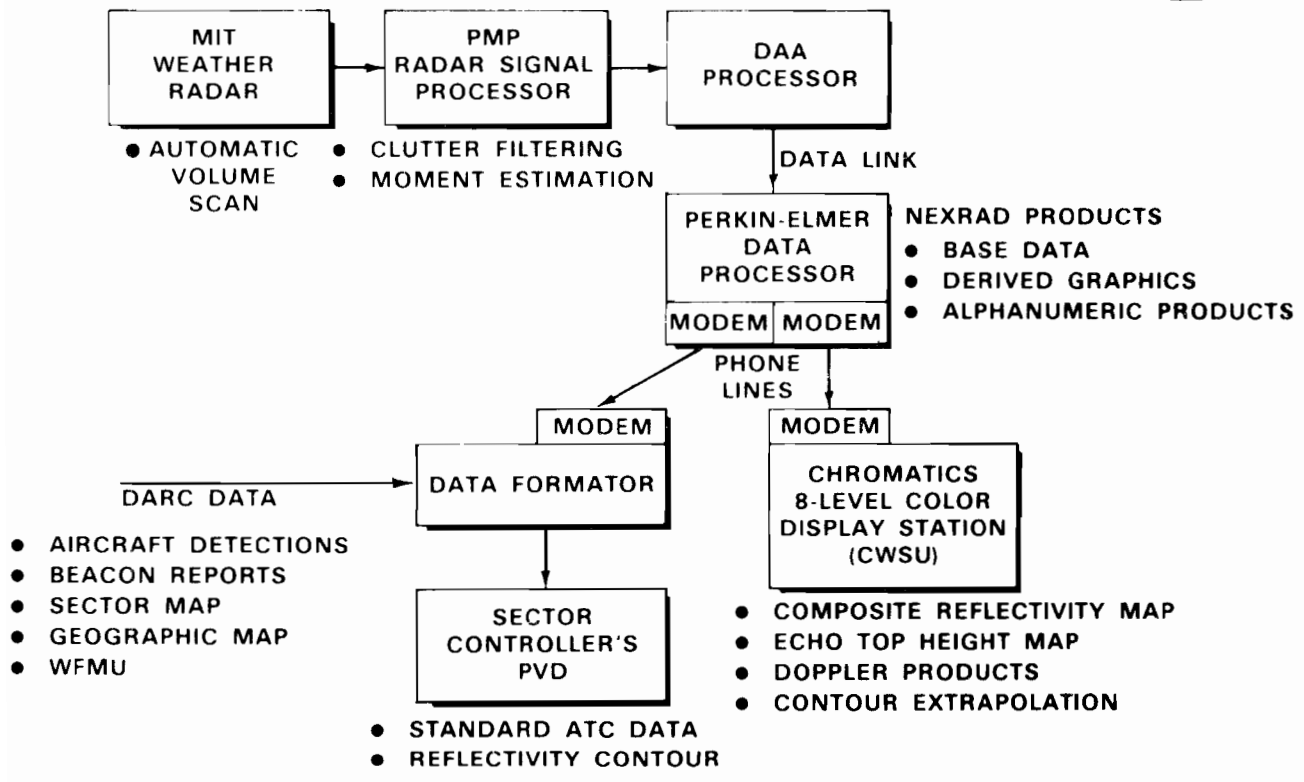

Fig. D-6. Suggested configuration for display of weather products at an ARTCC.

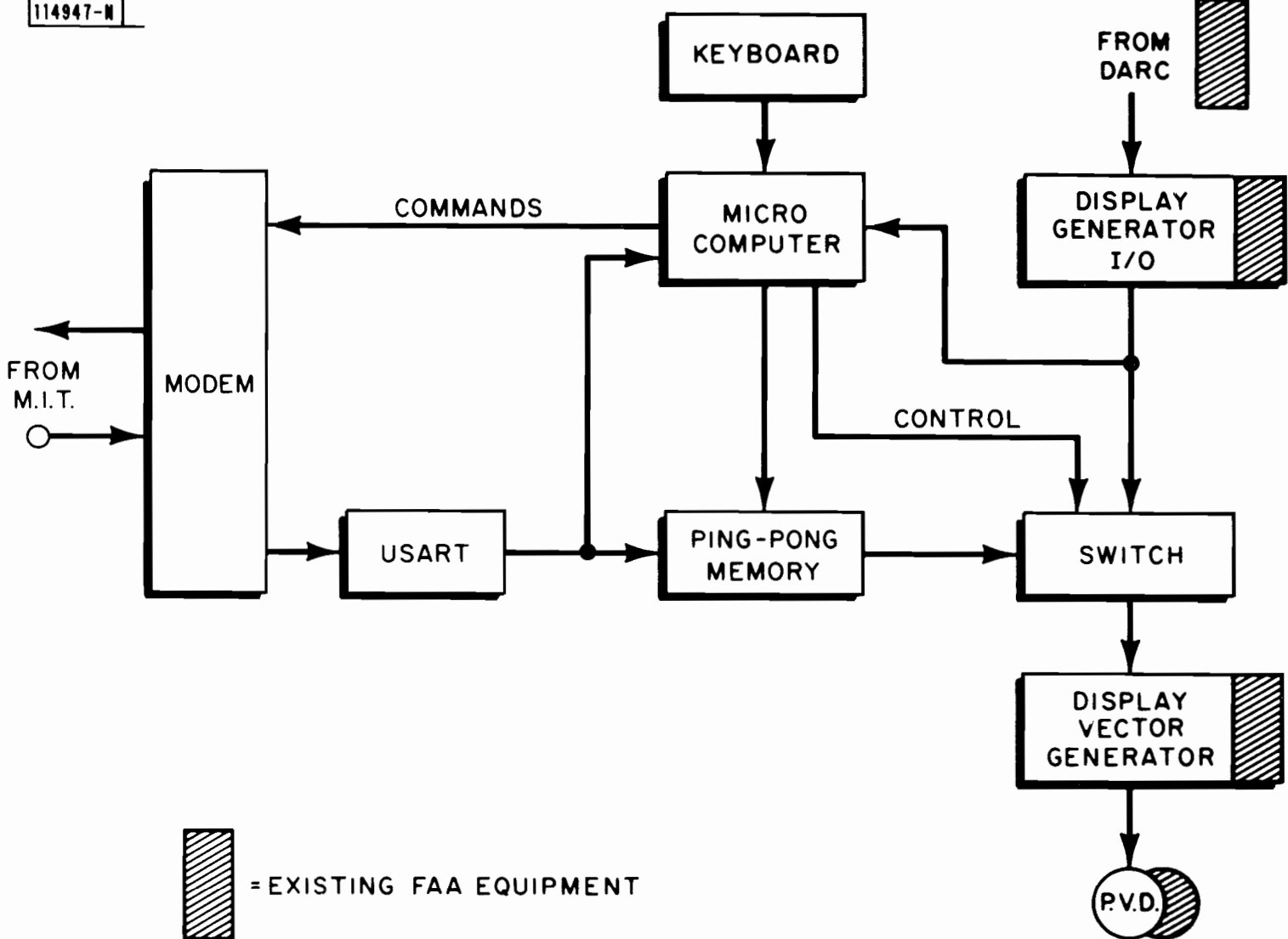

Fig. D-7. Display multiplexing of targets and weather information at an ARTCC.

- (a) only New England weather will be investigated, a region which is not noted for a high frequency of convective storms.
- (b) the clutter environment and visibility from this site are probably not typical of the bulk of NEXRAD sites that will be used by the FAA,
- (c) no data will be available from an airport location to validate terminal area performance, and
- (d) a number of potentially useful hardware features (e.g., STC optimized for clear air LLWS detection) may not be possible due to the need to not interfere with the M.I.T. meteorological research program.

Consequently, the M.I.T. radar cannot serve as a substitute for the transportable testbed system discussed in Chapter III.